

YOU

INTELLIGENTLY?

MACHINING

ISCAR TURNING LINES

Metric Catalog

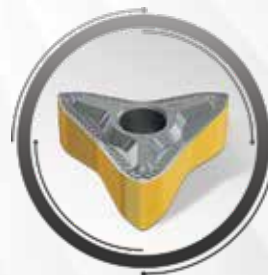
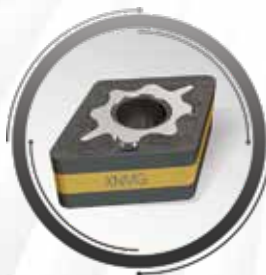

ISO
TURNING

GROOVING

PARTING

FACE
GROOVING

TOOL
BLOCKS

THREADING

HOLDERS

GRADES



THE STANDARDS INSTITUTION OF ISRAEL



THE STANDARDS INSTITUTION OF ISRAEL



THE STANDARDS INSTITUTION OF ISRAEL



THE STANDARDS INSTITUTION OF ISRAEL



THE STANDARDS INSTITUTION OF ISRAEL



THE STANDARDS INSTITUTION OF ISRAEL

Quality Standard

ISCAR has been certified by the prestigious Standards Institution, as being in full compliance to ensure delivery of the finest quality goods. Quality control facilities include the metallurgical laboratory, raw metal testing, an online testing procedure and a machining center for tool performance testing and final product inspection. Only the finest products are packaged for entry into ISCAR's inventory.

THREADING TOOLS AND INSERTS

YOU

INTELLIGENTLY?

THREADING



CONTENTS

THREADING INSERTS 712

SELECTION GUIDE 713

Insert Identification System 714

Partial Profile 55° (Whitworth) 715

Partial Profile 60° 721

Full Profile ISO 734

Full Profile UN 745

Full Profile W (Whitworth BSW, BSF, BSP) 755

NPT 760

Full Profile NPTF 765

BSPT British Standard Pipe 766

STACME 768

ACME 770

Partial Topping ACME 773

UNJ 775

MJ 778

TR Trapez 780

PG (Panzergewinde) 782

SAGE (Sagengewinde) Metric Buttress DIN 513 783

ABUT (American Buttress) 784

API RD (API ROUND)..... 786

API 788

BUT (API BUTRESS CASING)..... 790

Extreme Line Casing 791

RND DIN 405 Round 792

Anvils 793

THREADING TOOLS 795

External Threading Toolholders 798
 Internal Threading Toolholders 801
 Interchangeable Boring Heads for Threading Inserts..... 805
 Tools for External Grooving and Threading Inserts 807
 PICCOCUT Picco MG/PCO and ACE Holders..... 808



USER GUIDE 809

Cutting Speed Recommendations 809
 Threading Materials Grades Chart 810

THREADING INSERTS



Main Types of Laydown Inserts



B/M-TYPE	U-TYPE	REGULAR TYPE	MULTI-TOOTH
			





Additional Threading Systems

External



CUT-GRIP External	
	
	

SWISSCUT External	
	
	



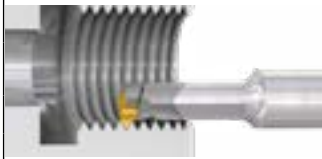

PENTACUT External	
	
	

-  Partial profile
-  Full profile



Internal

MINICHAM Internal	
	
	



Minimum bore dia. 4 mm

PICCOCUT Mini-Bar	
	
	



Minimum bore dia. 2.4 mm

CHAMGROOVE Internal	
	
	

Minimum bore dia. 8.0 mm

CUT-GRIP Internal	
	
	

Minimum bore dia. 12.5 mm

Minimum bore dia. 20 mm

-  Partial profile
-  Full profile

Insert Identification System



1. Insert Size

I (mm)	IC
06	5/32"
08	3/16"
11	1/4"
16	3/8"
22	1/2"
27	5/8"

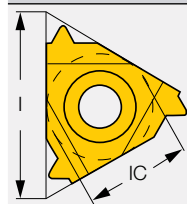

2. Application

E	External
I	Internal
UE	U-type, External
UI	U-type, Internal
UEI	U-type, External and Internal

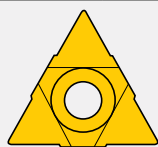

U-type

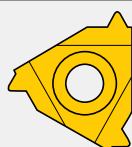

Regular Type

3. Hand of Tool

R	Right-hand
L	Left-hand
RL	Right- and Left-hand

4. Type

B	Peripherally ground & chipformer
M	Press to size with a chipformer
<input type="checkbox"/>	No indication regular type

5. Pitch

Full Profile (value by number)

0.35-9.0 mm

72-2 TPI

Partial Profile (range by letter)

	mm	TPI
A	0.5-1.5	48-16
AG	0.5-3.0	48-8
G	1.75-3.0	14-8
N	3.5-5.0	7-5
Q	5.5-6.0	4.5-4
U	5.5-9.0	4.5-2.75

6. Thread Standard

60	Partial Profile 60°
55	Partial Profile 55°
ISO	ISO Metric
UN	American UN
W	Whitworth
BSPT	British BSPT
RND	Round DIN 405
TR	Trapeze DIN 103
ACME	ACME
STACME	Stub ACME
ABUT	American Buttress
UNJ	UNJ
NPT	NPT
API RD	API Round
BUT	API Buttress Casing
API	API
H90	H-90
EL	Extreme Line Casing
MJ	ISO 5855

7. No. of Teeth (Optional)

2M	2 teeth
3M	3 teeth

8. Grade

IC1007
IC908
IC808
IC508
IC250
IC228
IC50M
IC806

ER/L-55°

External Laydown Threading
Inserts with a 55° Partial Profile
for General Applications

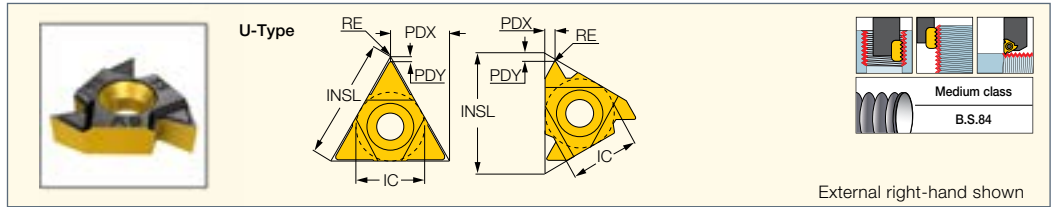

External right-hand shown

Designation	Dimensions							Tough ↔ Hard					
	IC	TPIN ⁽²⁾	TPIX ⁽³⁾	INSL	RE	PDX	PDY	IC228	IC50M	IC250	IC808	IC908	IC1007
11ER A 55 IC250	6.35	16.00	48.00	11.00	0.05	0.90	0.80			•			
11ER A 55 IC908	6.35	16.00	48.00	11.00	0.05	0.90	0.80					•	
16EL A 55 IC250	9.52	16.00	48.00	16.49	0.05	0.90	0.80			•			
16EL A 55 IC50M	9.52	16.00	48.00	16.49	0.05	0.90	0.80		•				
16ER A 55 IC250	9.52	16.00	48.00	16.49	0.06	0.90	0.80			•			
16ER A 55 IC50M	9.52	16.00	48.00	16.49	0.06	0.90	0.80		•				
16ER A 55 IC908	9.52	16.00	48.00	16.49	0.06	0.90	0.80					•	
16ER/L AG 55 IC250	9.52	8.00	48.00	16.49	0.07	1.70	1.20			•			
16EL AG 55 IC908	9.52	8.00	48.00	16.49	0.07	1.70	1.20					•	
16ER AG 55 IC1007	9.52	8.00	48.00	16.49	0.07	1.70	1.00						•
16ER AG 55 IC228	9.52	8.00	48.00	16.49	0.07	1.70	1.20	•					
16ER AG 55 IC908	9.52	8.00	48.00	16.49	0.07	1.70	1.20					•	
16ERB AG 55 IC908 ⁽¹⁾	9.52	8.00	48.00	16.49	0.07	1.70	1.20					•	
16ERM AG 55 IC1007 ⁽¹⁾	9.52	8.00	48.00	16.49	0.07	1.70	1.20						•
16ERM AG 55 IC250 ⁽¹⁾	9.52	8.00	48.00	16.49	0.07	1.70	1.20			•			
16ERM AG 55 IC50M ⁽¹⁾	9.52	8.00	48.00	16.49	0.07	1.70	1.20		•				
16ERM AG 55 IC808 ⁽¹⁾	9.52	8.00	48.00	16.49	0.07	1.70	1.20				•		
16ERM AG 55 IC908 ⁽¹⁾	9.52	8.00	48.00	16.49	0.07	1.70	1.20					•	
16EL G 55 IC250	9.52	8.00	14.00	16.49	0.23	1.70	1.17			•			
16ER G 55 IC250	9.52	8.00	14.00	16.49	0.23	1.70	1.20			•			
16ER G 55 IC908	9.52	8.00	14.00	16.49	0.23	1.70	1.17					•	
16ERB G 55 IC908 ⁽¹⁾	9.52	8.00	14.00	16.49	0.23	1.70	1.20					•	
16ERM G 55 IC1007	9.52	8.00	14.00	16.49	0.25	1.70	1.15						•
16ERM G 55 IC250 ⁽¹⁾	9.52	8.00	14.00	16.49	0.25	1.70	1.15			•			
16ERM G 55 IC808 ⁽¹⁾	9.52	8.00	14.00	16.49	0.25	1.70	1.14				•		
16ERM G 55 IC908 ⁽¹⁾	9.52	8.00	14.00	16.49	0.25	1.70	1.14					•	
22EL N 55 IC250	12.70	5.00	7.00	22.00	0.42	2.50	1.70			•			
22ER N 55 IC250	12.70	5.00	7.00	22.00	0.48	2.50	1.70			•			
22ER N 55 IC908	12.70	5.00	7.00	22.00	0.48	2.50	1.70					•	
22UEIRL U 55 IC250	12.70	3.25	4.50	22.00	0.60	11.00	0.90			•			
22UEIRL U 55 IC50M	12.70	3.25	4.50	22.00	0.60	11.00	0.90		•				
27ER Q 55 IC250	15.88	4.00	4.50	27.50	0.60	2.90	2.00			•			
27ER Q 55 IC908	15.88	4.00	4.50	27.50	0.60	2.90	2.00					•	
27UEIRL U 55 IC250	15.88	2.75	4.00	27.50	0.81	13.70	1.20			•			

- For insert identification system, see page 714
- For threading between walls use GRIP-type inserts TIP-WT, GEPI-WT, TIPI-WT
- For detailed cutting data, see page 809
- ⁽¹⁾ With pressed chipformer
- ⁽²⁾ Threads per inch minimum
- ⁽³⁾ Threads per inch maximum

For tools, see pages: C#-SER/L (799) • NQCH-SER/L-JHP (800) • SBTT#-16ER/L-JHP (418) • SER-D (800) • SER/L (798) • SER/L-JHP (799) • SER/L-JHP-MC (800)

ISCAR THREAD

IR/L-55°
Internal Laydown Threading
Inserts with a 55° Partial Profile
for General Applications

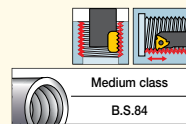
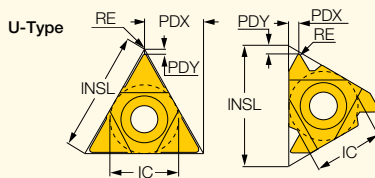

Medium class
B.S.84

Internal left-hand shown

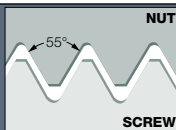

Designation	Dimensions							Tough ↔ Hard							
	IC	TPIX ⁽²⁾	TPIN ⁽³⁾	INSL	RE	PDX	PDY	IC228	IC928	IC50M	IC250	IC508	IC808	IC908	IC1007
06IL A 55 IC228	4.00	48.00	20.00	6.88	0.07	0.60	0.55	•							
06IR A 55 IC228	4.00	48.00	20.00	6.88	0.08	0.60	0.55	•							
08IL A 55 IC228	5.00	48.00	16.00	8.24	0.08	0.70	0.60	•							
08IR A 55 IC228	5.00	48.00	16.00	8.24	0.08	0.70	0.60	•							
08IR A 55 IC908	5.00	48.00	16.00	8.24	0.08	0.70	0.60							•	
08IR A 55 IC928	5.00	48.00	16.00	8.24	0.08	0.70	0.60		•						
08UIRL U 55 IC228	5.00	18.00	12.00	8.66	0.10	4.33	0.90	•							
11IL A 55 IC250	6.35	48.00	16.00	11.00	0.05	0.90	0.80				•				
11IL A 55 IC908	6.35	48.00	16.00	11.00	0.05	0.90	0.80							•	
11IR A 55 IC1007	6.35	48.00	16.00	11.00	0.05	0.90	0.80								•
11IR A 55 IC228	6.35	48.00	16.00	11.00	0.05	0.90	0.80	•							
11IR A 55 IC250	6.35	48.00	16.00	11.00	0.05	0.90	0.80				•				
11IR A 55 IC908	6.35	48.00	16.00	11.00	0.05	0.90	0.80							•	
16IR A 55 IC50M	9.52	48.00	16.00	16.49	0.05	0.90	0.80			•					
16IR A 55 IC908	9.52	48.00	16.00	16.49	0.05	0.90	0.80							•	
16IL AG 55 IC908	9.52	48.00	8.00	16.49	0.07	1.70	1.20							•	
16IR AG 55 IC250	9.52	48.00	8.00	16.49	0.07	1.70	1.20				•				
16IR AG 55 IC908	9.52	48.00	8.00	16.49	0.07	1.70	1.20							•	
16IRB AG 55 IC908 ⁽¹⁾	9.52	48.00	8.00	16.49	0.07	1.70	1.20							•	
16IRM AG 55 IC1007 ⁽¹⁾	9.52	48.00	8.00	16.49	0.05	1.70	1.20								•
16IRM AG 55 IC250 ⁽¹⁾	9.52	48.00	8.00	16.49	0.05	1.70	1.20				•				
16IRM AG 55 IC808 ⁽¹⁾	9.52	48.00	8.00	16.49	0.05	1.70	1.20						•		
16IRM AG 55 IC908 ⁽¹⁾	9.52	48.00	8.00	16.49	0.05	1.70	1.20							•	
16IL G 55 IC908	9.52	14.00	8.00	16.49	0.20	1.70	1.20							•	
16IR G 55 IC250	9.52	14.00	8.00	16.49	0.23	1.70	1.20				•				
16IR G 55 IC508	9.52	14.00	8.00	16.49	0.23	1.70	1.20					•			
16IR G 55 IC908	9.52	14.00	8.00	16.49	0.23	1.70	1.20							•	
16IRB G 55 IC908 ⁽¹⁾	9.52	14.00	8.00	16.49	0.23	1.70	1.20							•	
16IRM G 55 IC1007	9.52	14.00	8.00	16.49	0.20	1.70	1.20								•
16IRM G 55 IC250 ⁽¹⁾	9.52	14.00	8.00	16.49	0.20	1.70	1.20				•				
16IRM G 55 IC808 ⁽¹⁾	9.52	14.00	8.00	16.49	0.20	1.70	1.20						•		
16IRM G 55 IC908 ⁽¹⁾	9.52	14.00	8.00	16.49	0.20	1.70	1.20							•	
22IR N 55 IC250	12.70	7.00	5.00	22.00	0.42	2.50	1.70				•				
22IR N 55 IC50M	12.70	7.00	5.00	22.00	0.42	2.50	1.70			•					
22IR N 55 IC908	12.70	7.00	5.00	22.00	0.42	2.50	1.70							•	
27IR Q 55 IC908	15.88	4.00	4.50	27.50	0.60	2.90	2.00							•	

- For insert identification system, see page 714
- For threading between walls use GRIP-type inserts TIP-WT, GEPI-WT, TIPI-WT.
- For detailed cutting data, see page 809

⁽¹⁾ With pressed chipformer

⁽²⁾ Threads per inch maximum

⁽³⁾ Threads per inch minimum

For tools, see pages: AVC-D-SIR/L (805) • C#-SIR/L (803) • MGSIR/L (156) • PICIN-A-SIR/L (466) • PICIN-MGSIR/L (466) • SIR/L (801)

PENTA 17-WT-RS/LS
Precision Ground Pentagonal
External Threading Inserts
with a 55° Partial Profile
for General Applications

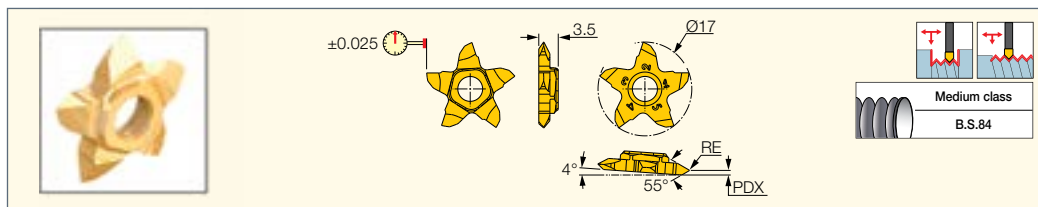

Designation	Dimensions				IC1008
	TPIX ⁽¹⁾	TPIN ⁽²⁾	RE	PDX	
PENTA 17-WTL003LS IC1008	72.00	16.00	0.03	0.80	●
PENTA 17-WTR003RS IC1008	72.00	16.00	0.03	0.80	●
PENTA 17-WTL008LS IC1008	31.00	8.00	0.08	1.40	●
PENTA 17-WTR008RS IC1008	31.00	8.00	0.08	1.40	●

⁽¹⁾ Threads per inch maximum

⁽²⁾ Threads per inch minimum

For tools, see pages: NQCH-PCHR/L-S-JHP (433) • PCADRS/LS-JHP (354) • PCHRS/LS-17 (339) • PCHRS/LS-17-JHP (340) • Y-PCHRS-17 (340)

• Y-PCHRS-17-JHP (341)

PENTA 24-WT
Precision Ground Pentagonal
External Threading Inserts
with a Whitworth 55°
Partial Profile

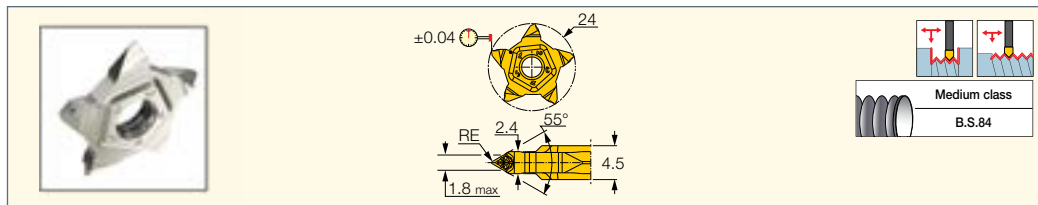

Designation	Dimensions			IC908
	TPIX ⁽²⁾	TPIN ⁽³⁾	RE	
PENTA 24A-WT-0.15 IC908 ⁽¹⁾	24.00	8.00	0.15	●
PENTA 24A-WT-0.05 IC908 ⁽¹⁾	80.00	8.00	0.05	●

• TPIN=6.4/D(inch) D-nominal thread diameter (inch)

⁽¹⁾ Flat rake (without a chipformer)

⁽²⁾ Threads per inch maximum

⁽³⁾ Threads per inch minimum

For tools, see pages: NQCH-PCHR/L-24-JHP (348) • PCAD RE/LE-JHP (561) • PCADR/L (353) • PCADR/L-JHP (353) • PCHBR/L (355) • PCHR/L-24 (346)

• PCHR/L-24-JHP (347) • PCHR/L-24-JHP-MC (348)

CUTGRIP
ISCARTHREAD

TIP-WT
Precision Ground Double-Ended Threading Inserts with a 55° Partial Profile and a Chipformer

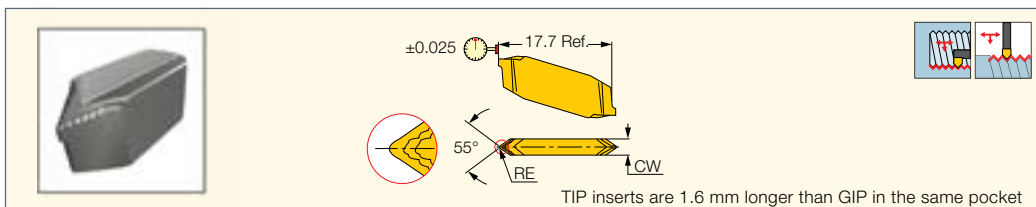

TIP inserts are 1.6 mm longer than GIP in the same pocket

 Designation	Dimensions					Tough ↔ Hard	
	CW	RE	RETOL ⁽²⁾	TPIX ⁽³⁾	TPIN ⁽⁴⁾	IC08	IC908
TIP 2WT-0.05 IC08	2.40	0.05	0.030	54.00	12.00	●	
TIP 2WT-0.05 IC908 ⁽¹⁾	2.40	0.05	0.030	54.00	12.00		●
TIP 4WT-0.15 IC08	4.00	0.15	0.030	19.00	7.00	●	
TIP 4WT-0.15 IC908 ⁽¹⁾	4.00	0.15	0.030	19.00	7.00		●
TIP 5WT-0.25 IC908 ⁽¹⁾	5.50	0.25	0.030	12.00	6.00		●

- Toolholder seat needs to be modified according to insert profile to ensure clearance
- Pitch max 0.187xD
- Internal & External tolerance: B.S.84 Medium class
- ⁽¹⁾ TPIN(thread per inch minimum) = D/6.4
- D-Diameter of thread (inch)
- ⁽²⁾ Corner radius tolerance (+/-)
- ⁽³⁾ Threads per inch maximum
- ⁽⁴⁾ Threads per inch minimum

For tools, see pages: C#-GHDR/L (301) • CGHN 26-M (399) • CGHN 32-DGM (400) • CGHN 32-M (400) • CGHN-D (310) • CGHN-DG (310) • CGHN-S (309) • CGPAD (308) • CGPAD-JHP (309) • GHDR/L (short pocket) (302) • GHDR/L-JHP (short pocket) (303) • GHDR/L-JHP-MC (short pocket) (304) • GHGR/L (305) • GHMPR/L (300) • GHMR/L (300) • GHSR/L (428) • GHSR/L-JHP-SL (429) • NQCH-GHSR/L-JHP (428)

CUTGRIP
ISCARTHREAD

GEPI-WT
Precision Ground Double-Ended Threading Inserts with a 55° Partial Profile and a Chipformer for 11.5 mm Bore Diameter

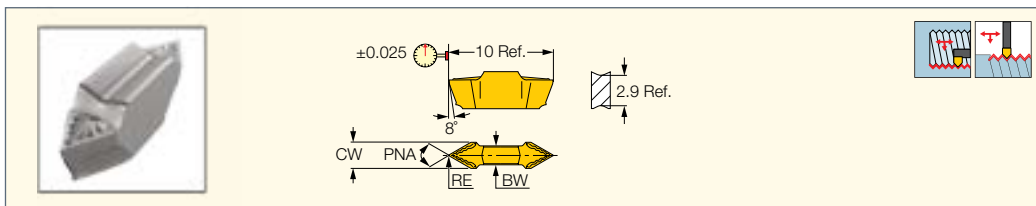

 Designation	Dimensions									Tough ↔ Hard	
	CW	RE	RETOL ⁽¹⁾	PNA	BW	TPN ⁽²⁾	TPX ⁽³⁾	TPIN ⁽⁴⁾	TPIX ⁽⁵⁾	IC08	IC908
GEPI 2.5-WT0.05 IC08	2.50	0.05	0.030	55.0	1.80	0.470	2.540	10.00	54.00	●	
GEPI 2.5-WT0.05 IC908	2.50	0.05	0.030	55.0	1.80	0.470	2.540	10.00	54.00		●

- Toolholder seat needs to be modified according to insert profile to ensure clearance
- Pitch max 0.167xD, TPI min D/6.0 • Internal & External tolerance: B.S.84 Medium class
- ⁽¹⁾ Corner radius tolerance (+/-)
- ⁽²⁾ Thread pitch minimum (mm)
- ⁽³⁾ Thread pitch maximum (mm)
- ⁽⁴⁾ Threads per inch minimum
- ⁽⁵⁾ Threads per inch maximum

For tools, see pages: AVC-GEAIR/L (389) • E-GEHIR / E-GHIR (383) • GEAIR/L (383) • GEHIMR/L (380) • GEHIMR/L-SC (380) • GEHIR/L (381) • GEHIR/L-SC (382) • GEHSR (427) • GEHSR/L-SL (426)

CUTGRIP
ISCARTHREAD

TIPI-WT
Double-Ended Internal Threading Inserts with a 55° Partial Profile and a Chipformer for 20 mm Min. Bore Diameter

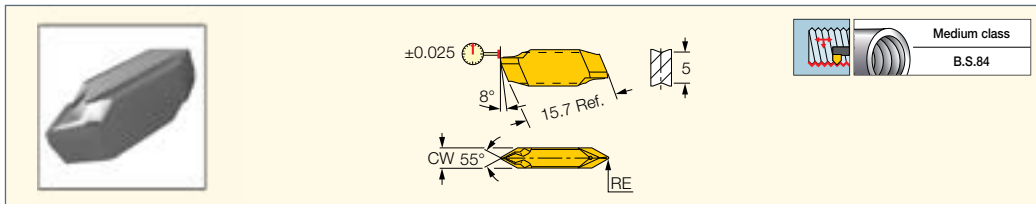

Designation	Dimensions						Tough ↔ Hard	
	CW	RE	RETOL ⁽¹⁾	TPN ⁽²⁾	TPIX ⁽³⁾	TPIN ⁽⁴⁾	IC08	IC908
TIPI 3.4WT-0.10 IC08	3.40	0.10	0.030	0.950	27.00	8.00	●	
TIPI 3.4WT-0.10 IC908	3.40	0.10	0.030	0.950	27.00	8.00		●
TIPI 5.4WT-0.20 IC908	5.40	0.20	0.030	1.670	15.00	5.00		●

- Toolholder seat needs to be modified according to insert profile to ensure clearance
 - Pitch max 0.187xD, TPI min D/5.25 D=Diameter of thread (pitch max<=CW)
 - (1) Corner radius tolerance (+/-)
 - (2) Thread pitch minimum (mm)
 - (3) Threads per inch maximum
 - (4) Threads per inch minimum
- For tools, see pages:** AVC-GAIR/L (390) • GAIR/L (389) • GHIR/L (W=1.9-6.4) (387) • GHIR/L-SC (W=2-4.8) (388)

MINICHAM
ISCARTHREAD

UMGR-A55
Mini Indexable Inserts with Whitworth Partial Profile for Threading in 5.2 mm and Larger Holes

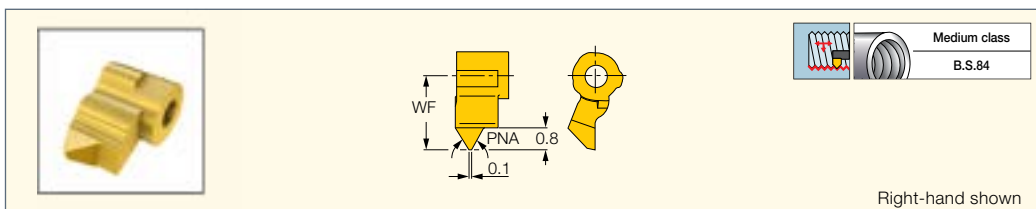

Designation	Dimensions							IC508
	WF	PNA	TPIX ⁽¹⁾	TPIN ⁽²⁾	TPN ⁽³⁾	TPX ⁽⁴⁾	DMIN	
UMGR 4.0-A55 IC508	2.70	55.0	40.00	24.00	0.500	1.400	5.20	●

- (1) Threads per inch maximum
 - (2) Threads per inch minimum
 - (3) Thread pitch minimum (mm)
 - (4) Thread pitch maximum (mm)
- For tools, see page:** MGUHR (467)

CHAMGROOVE
ISCARTHREAD

GIQR/L-WT
Internal Inserts with Whitworth Partial Profile for Threading in 8 mm and Larger Holes

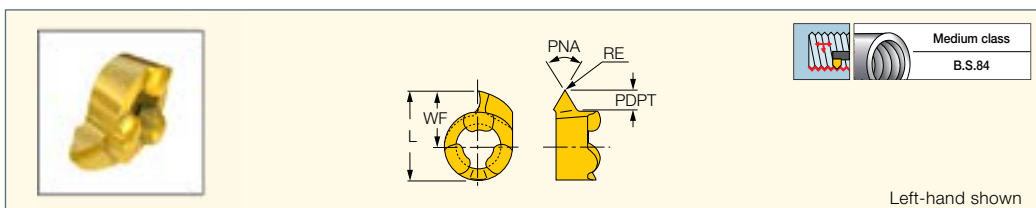

Designation	Dimensions									IC528
	L	RE	PNA	PDPT ⁽¹⁾	WF	DMIN	TPIN ⁽²⁾	TPIX ⁽³⁾		
GIQR/L 8-WT-0.05 IC528	7.78	0.05	55.0	1.50	4.80	8.00	16.00	50.00	●	
GIQR/L 11-WT-0.05 IC528	10.68	0.05	55.0	2.00	6.70	11.00	11.00	50.00	●	

- Can be used for thread milling by circular interpolation • TPI min D/5.9
 - D-diameter of thread (pitch max<=W)
 - For cutting speed recommendations, see page 809
 - (1) Cutting depth maximum
 - (2) Threads per inch minimum
 - (3) Threads per inch maximum
- For tools, see pages:** MG (470) • MGCH (470)

PICCOJET
COOLANT THROUGH
ISCAR THREAD

PICJ RTH (55° Threading)
Inserts with Inner Coolant Channel for 55° Internal Threading Profile

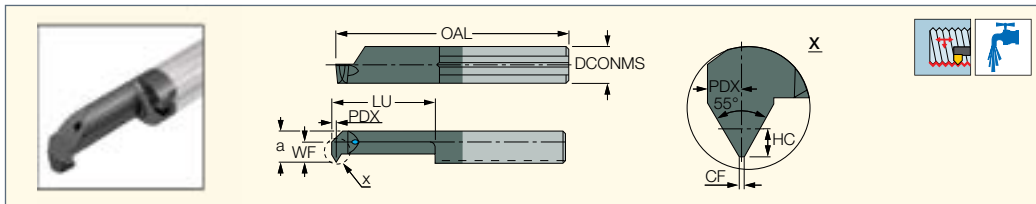

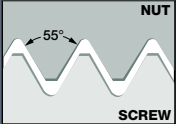
 Designation	Dimensions											IC908
	DCONMS	DMIN	HC	CF	PDX	WF	a	OHN ⁽¹⁾	OAL	TPIX ⁽²⁾	TPIN ⁽³⁾	
PICJ RTH14W24D060	6.00	6.00	0.81	0.12	0.80	2.30	5.30	15.0	30.00	24.00	16.00	●
PICJ RTH14W24D070	7.00	7.00	0.81	0.12	0.80	2.80	6.30	15.0	30.00	24.00	16.00	●

NEW

- All mini-bars have sharp corners
- For detailed cutting data, see page 823
- PICJ items are suitable for: PICCO ACE (440) • PICCO/MG PCO (Holder) (441) • SC-PICCO (420) type holders only

⁽¹⁾ Minimum overhang
⁽²⁾ Threads per inch maximum
⁽³⁾ Threads per inch minimum

PICCO CUT
ISCAR THREAD

PICCO-55°-Thread
Inserts for 55° Internal Thread Profile

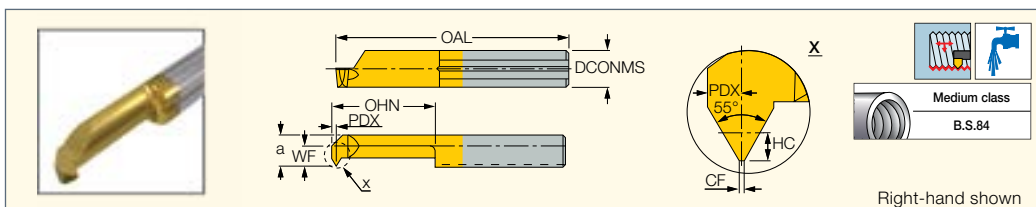

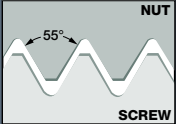
 Designation	Dimensions											IC228
	DCONMS	DMIN	HC	CF	PDX	WF	a	OHN ⁽¹⁾	OAL	TPIN ⁽²⁾	TPIX ⁽³⁾	
PICCO R 005.5548-15	5.00	4.80	0.40	0.06	0.50	1.90	4.40	15.0	30.00	24.00	48.00	●
PICCO R 006.5548-15	6.00	6.00	0.40	0.06	0.50	2.30	5.30	15.0	30.00	24.00	48.00	●
PICCO R 006.5524-15	6.00	6.00	0.81	0.12	0.80	2.30	5.30	15.0	30.00	16.00	24.00	●
PICCO R 007.5524-15	7.00	7.00	0.81	0.12	0.80	2.80	6.30	15.0	30.00	16.00	24.00	●

- All mini-bars have sharp corners
- For detailed cutting data, see page 823

⁽¹⁾ Minimum overhang
⁽²⁾ Threads per inch minimum
⁽³⁾ Threads per inch maximum

For holders, see pages: PICCO ACE (440) • PICCO/MG PCO (Holder) (441) • SC-PICCO (420)



ER/L-60°
External Laydown Threading
Inserts with a 60° Partial Profile
for General Applications

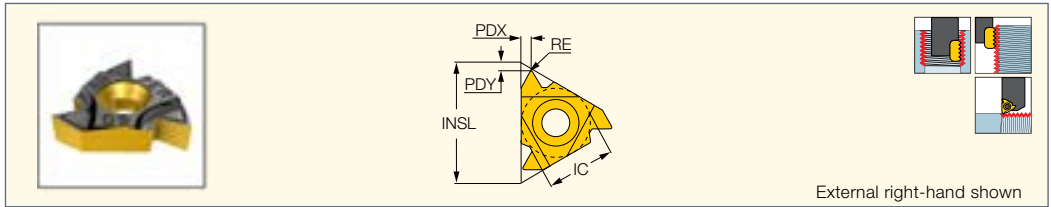

External right-hand shown

Designation	Dimensions									Tough ↔ Hard							
	IC	TPN ⁽²⁾	TPX ⁽³⁾	TPIN ⁽⁴⁾	TPIX ⁽⁵⁾	INSL	RE	PDX	PDY	IC228	IC50M	IC250	IC08	IC508	IC808	IC908	IC1007
11EL A 60 IC908	6.35	0.500	1.500	16.00	48.00	11.00	0.05	0.90	0.80							•	
11ER A 60 IC908	6.35	0.500	1.500	16.00	48.00	11.00	0.06	0.90	0.80							•	
16EL A 60 IC250	9.52	0.500	1.500	16.00	48.00	16.49	0.08	0.90	1.00			•					
16EL A 60 IC50M	9.52	0.500	1.500	16.00	48.00	16.49	0.07	0.90	1.00		•						
16EL A 60 IC908	9.52	0.500	1.500	16.00	48.00	16.49	0.07	0.90	1.00							•	
16ER A 60 IC08	9.52	0.500	1.500	16.00	48.00	16.49	0.07	0.80	1.00				•				
16ER A 60 IC1007	9.52	0.500	1.500	16.00	48.00	16.49	0.07	0.90	1.00								•
16ER A 60 IC228	9.52	0.500	1.500	16.00	48.00	16.49	0.07	0.90	1.00	•							
16ER A 60 IC250	9.52	0.500	1.500	16.00	48.00	16.49	0.07	0.90	1.00			•					
16ER A 60 IC908	9.52	0.500	1.500	16.00	48.00	16.49	0.07	0.80	1.00							•	
16ERB A 60 IC08 ⁽¹⁾	9.52	0.500	1.500	16.00	48.00	16.49	0.07	0.80	1.00				•				
16ERB A 60 IC908 ⁽¹⁾	9.52	0.500	1.500	16.00	48.00	16.49	0.07	0.80	1.00							•	
16ERM A 60 IC1007 ⁽¹⁾	9.52	0.500	1.500	16.00	48.00	16.49	0.07	0.90	0.80								•
16ERM A 60 IC250 ⁽¹⁾	9.52	0.500	1.500	16.00	48.00	16.49	0.07	0.90	0.80			•					
16ERM A 60 IC50M ⁽¹⁾	9.52	0.500	1.500	16.00	48.00	16.49	0.07	0.90	0.80		•						
16ERM A 60 IC808 ⁽¹⁾	9.52	0.500	1.500	16.00	48.00	16.49	0.07	0.90	0.80					•			
16ERM A 60 IC908 ⁽¹⁾	9.52	0.500	1.500	16.00	48.00	16.49	0.07	0.90	0.80							•	
16EL AG 60 IC250	9.52	0.500	3.000	8.00	48.00	16.49	0.06	1.70	1.20			•					
16EL AG 60 IC50M	9.52	0.500	3.000	8.00	48.00	16.49	0.06	1.70	1.20		•						
16EL AG 60 IC908	9.52	0.500	3.000	8.00	48.00	16.49	0.06	1.70	1.20							•	
16ER AG 60 IC08	9.52	0.500	3.000	8.00	48.00	16.49	0.06	1.70	1.20				•				
16ER AG 60 IC1007	9.52	0.500	3.000	8.00	48.00	16.49	0.08	1.50	1.20								•
16ER AG 60 IC228	9.52	0.500	3.000	8.00	48.00	16.49	0.08	1.70	1.20	•							
16ER AG 60 IC250	9.52	0.500	3.000	8.00	48.00	16.49	0.08	1.70	1.20			•					
16ER AG 60 IC50M	9.52	0.500	3.000	8.00	48.00	16.49	0.08	1.70	1.20		•						
16ER AG 60 IC508	9.52	0.500	3.000	8.00	48.00	16.49	0.08	1.50	1.20					•			
16ER AG 60 IC908	9.52	0.500	3.000	8.00	48.00	16.49	0.08	1.50	1.20							•	
16ERB AG 60 IC908 ⁽¹⁾	9.52	0.500	3.000	8.00	48.00	16.49	0.06	1.70	1.20							•	
16ERM AG 60 IC1007 ⁽¹⁾	9.52	0.500	3.000	8.00	48.00	16.49	0.08	1.70	1.20								•
16ERM AG 60 IC250 ⁽¹⁾	9.52	0.500	3.000	8.00	48.00	16.49	0.08	1.70	1.20			•					
16ERM AG 60 IC50M ⁽¹⁾	9.52	0.500	3.000	8.00	48.00	16.49	0.08	1.70	1.20		•						
16ERM AG 60 IC508 ⁽¹⁾	9.52	0.500	3.000	8.00	48.00	16.49	0.08	1.70	1.20					•			
16ERM AG 60 IC808 ⁽¹⁾	9.52	0.500	3.000	8.00	48.00	16.49	0.08	1.70	1.20						•		
16ERM AG 60 IC908 ⁽¹⁾	9.52	0.500	3.000	8.00	48.00	16.49	0.08	1.70	1.20							•	

- For Insert Identification System, see page 714 • For threading between walls use GRIP-type inserts SCIR/L B/F -MTR/L, TIP-MT, GEPI-MT, TIPI-MT.
- For technical information and detailed cutting data, see pages 809-825 • DIN113 , ISO 68-1, ISO 965 (1&2) - External tolerance: 6g
- ANSI/ASME B1.1 - External tolerance: 2A

⁽¹⁾ With pressed chipformer
⁽²⁾ Thread pitch minimum (mm)
⁽³⁾ Thread pitch maximum (mm)
⁽⁴⁾ Threads per inch minimum
⁽⁵⁾ Threads per inch maximum

For tools, see pages: C#-SER/L (799) • NQCH-SER/L-JHP (800) • SBTT#-16ER/L-JHP (418) • SER-D (800) • SER/L (798) • SER/L-JHP (799) • SER/L-JHP-MC (800)

Continued

ISCAR THREAD

ER/L-60°

External Laydown Threading
Inserts with a 60° Partial Profile
for General Applications

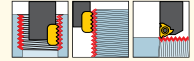
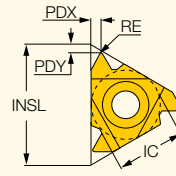

External right-hand shown

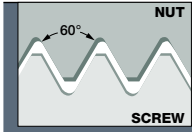

Designation	Dimensions									Tough ↔ Hard							
	IC	TPN ⁽²⁾	TPX ⁽³⁾	TPIN ⁽⁴⁾	TPIX ⁽⁵⁾	INSL	RE	PDX	PDY	IC228	IC50M	IC250	IC08	IC508	IC808	IC908	IC1007
16EL G 60 IC250	9.52	1.750	3.000	8.00	14.00	16.49	0.22	1.70	1.20			•					
16EL G 60 IC908	9.52	1.750	3.000	8.00	14.00	16.49	0.22	1.70	1.20							•	
16ER G 60 IC08	9.52	1.750	3.000	8.00	14.00	16.49	0.22	1.70	1.20				•				
16ER G 60 IC1007	9.52	1.750	3.000	8.00	14.00	16.49	0.22	1.70	1.20								•
16ER G 60 IC228	9.52	1.750	3.000	8.00	14.00	16.49	0.22	1.70	1.20	•							
16ER G 60 IC250	9.52	1.750	3.000	8.00	14.00	16.49	0.22	1.70	1.20			•					
16ER G 60 IC908	9.52	1.750	3.000	8.00	14.00	16.49	0.22	1.70	1.20							•	
16ERB G 60 IC908 ⁽¹⁾	9.52	1.750	3.000	8.00	14.00	16.49	0.22	1.70	1.20							•	
16ERM G 60 IC1007 ⁽¹⁾	9.52	1.750	3.000	8.00	14.00	16.49	0.25	1.50	1.00								•
16ERM G 60 IC250 ⁽¹⁾	9.52	1.750	3.000	8.00	14.00	16.49	0.25	1.50	1.00			•					
16ERM G 60 IC50M ⁽¹⁾	9.52	1.750	3.000	8.00	14.00	16.49	0.25	1.50	1.00		•						
16ERM G 60 IC808 ⁽¹⁾	9.52	1.750	3.000	8.00	14.00	16.49	0.25	1.50	1.00					•			
16ERM G 60 IC908 ⁽¹⁾	9.52	1.750	3.000	8.00	14.00	16.49	0.25	1.50	1.00							•	
22EL N 60 IC50M	12.70	3.500	5.000	5.00	7.00	22.00	0.42	2.50	1.70		•						
22EL N 60 IC908	12.70	3.500	5.000	5.00	7.00	22.00	0.42	2.50	1.70							•	
22ER N 60 IC08	12.70	3.500	5.000	5.00	7.00	22.00	0.42	2.50	1.70				•				
22ER N 60 IC1007	12.70	3.500	5.000	5.00	7.00	22.00	0.42	2.50	1.70								•
22ER N 60 IC228	12.70	3.500	5.000	5.00	7.00	22.00	0.42	2.50	1.70	•							
22ER N 60 IC250	12.70	3.500	5.000	5.00	7.00	22.00	0.42	2.50	1.70			•					
22ER N 60 IC50M	12.70	3.500	5.000	5.00	7.00	22.00	0.42	2.50	1.70		•						
22ER N 60 IC908	12.70	3.500	5.000	5.00	7.00	22.00	0.42	2.50	1.70							•	
22ERM N 60 IC1007 ⁽¹⁾	12.70	3.500	5.000	5.00	7.00	22.00	0.32	2.50	1.70								•
22ERM N 60 IC250 ⁽¹⁾	12.70	3.500	5.000	5.00	7.00	22.00	0.32	2.50	1.70			•					
22ERM N 60 IC50M ⁽¹⁾	12.70	3.500	5.000	5.00	7.00	22.00	0.32	2.50	1.70		•						
22ERM N 60 IC808 ⁽¹⁾	12.70	3.500	5.000	5.00	7.00	22.00	0.32	2.50	1.70					•			
22ERM N 60 IC908 ⁽¹⁾	12.70	3.500	5.000	5.00	7.00	22.00	0.32	2.50	1.70							•	
22UEIRL U 60 IC250	12.70	5.500	8.000	3.25	4.50	22.00	0.28	11.00	0.60			•					
22UEIRL U 60 IC908	12.70	5.500	8.000	3.25	4.50	22.00	0.28	11.00	0.60							•	
27EL Q 60 IC228	15.88	5.500	6.000	4.00	4.50	27.50	0.63	3.00	2.00	•							
27ER Q 60 IC250	15.88	5.500	6.000	4.00	4.50	27.50	0.63	3.00	2.00			•					
27ER Q 60 IC50M	15.88	5.500	6.000	4.00	4.50	27.50	0.63	3.00	2.00		•						
27ER Q 60 IC908	15.88	5.500	6.000	4.00	4.50	27.50	0.63	3.00	2.00							•	
27UEIRL U 60 IC250	15.88	6.500	9.000	2.75	4.00	27.50	0.50	13.75	1.03			•					
27UEIRL U 60 IC50M	15.88	6.500	9.000	2.75	4.00	27.50	0.50	13.75	1.03		•						

- For Insert Identification System, see page 714 • For threading between walls use GRIP-type inserts SCIR/L B/F -MTR/L, TIP-MT, GEPI-MT, TIPI-MT.
- For technical information and detailed cutting data, see pages 809-825 • DIN13 , ISO 68-1, ISO 965 (1&2) - External tolerance: 6g
- ANSI/ASME B1.1 - External tolerance: 2A

- ⁽¹⁾ With pressed chipformer
- ⁽²⁾ Thread pitch minimum (mm)
- ⁽³⁾ Thread pitch maximum (mm)
- ⁽⁴⁾ Threads per inch minimum
- ⁽⁵⁾ Threads per inch maximum

For tools, see pages: C#-SER/L (799) • NQCH-SER/L-JHP (800) • SBTT#-16ER/L-JHP (418) • SER-D (800) • SER/L (798) • SER/L-JHP (799) • SER/L-JHP-MC (800)

ISCAR THREAD

EIR/L U

External Laydown Threading
Inserts with a 60° Partial Profile
for General Applications

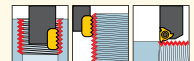
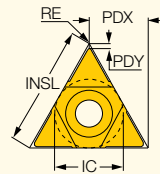

Designation	Dimensions													Tough ↔ Hard		
	IC	TPN ⁽¹⁾	TPX ⁽²⁾	TPN_DF2	TPX_DF2	TPIN ⁽³⁾	TPIX ⁽⁴⁾	TPIN_DF2	TPIX_DF2	INSL	RE	PDX	PDY	IC50M	IC250	IC908
22UEIRL U 60 IC250	12.70	3.000	8.000	1.750	8.000	4.00	8.00	4.00	14.00	22.00	0.28	11.00	0.60		•	
22UEIRL U 60 IC908	12.70	3.000	8.000	1.750	8.000	4.00	8.00	4.00	14.00	22.00	0.28	11.00	0.60			•
27UEIRL U 60 IC250	15.88	5.500	8.000	3.000	8.000	4.00	4.50	4.00	8.00	27.50	0.50	13.75	1.03		•	
27UEIRL U 60 IC50M	15.88	5.500	8.000	3.000	8.000	4.00	4.50	4.00	8.00	27.50	0.50	13.75	1.03	•		

- For Insert Identification System, see page 714

- ⁽¹⁾ Thread pitch minimum (mm)
- ⁽²⁾ Thread pitch maximum (mm)
- ⁽³⁾ Threads per inch minimum
- ⁽⁴⁾ Threads per inch maximum

For tools, see page: SER/L (798)

IR/L-60°
Internal Laydown Threading
Inserts with a 60° Partial Profile
for General Applications

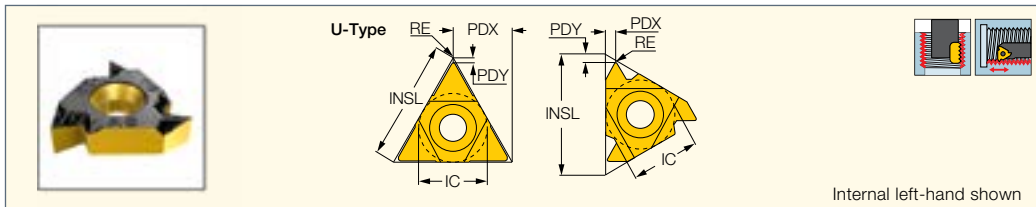

Designation	Dimensions									Tough ↔ Hard								
	IC	TPN ⁽²⁾	TPX ⁽³⁾	TPIN ⁽⁴⁾	TPIX ⁽⁵⁾	INSL	RE	PDY	PDX	IC28	IC228	IC50M	IC250	IC08	IC508	IC808	IC908	IC1007
06IL A 60 IC228	4.00	0.500	1.250	20.00	48.00	6.88	0.05	0.50	0.60		•							
06IR A 60 IC908	4.00	0.500	1.250	20.00	48.00	6.88	0.05	0.50	0.60								•	
06IR A 60 IC228	4.00	0.500	1.250	20.00	48.00	6.88	0.05	0.50	0.60		•							
06IR A 60 IC28	4.00	0.500	1.250	20.00	48.00	6.88	0.05	0.50	0.60	•								
06IRM A 60 IC228 ⁽¹⁾	4.00	0.500	1.250	20.00	48.00	6.88	0.05	0.50	0.60		•							
08IL A 60 IC228	5.00	0.500	1.500	16.00	48.00	8.24	0.05	0.60	0.70		•							
08IR A 60 IC08	5.00	0.500	1.500	16.00	48.00	8.24	0.05	0.50	0.70					•				
08IR A 60 IC1007	5.00	0.500	1.500	16.00	48.00	8.24	0.05	0.50	0.70									•
08IR A 60 IC228	5.00	0.500	1.500	16.00	48.00	8.24	0.05	0.50	0.70		•							
08IR A 60 IC28	5.00	0.500	1.500	16.00	48.00	8.24	0.05	0.50	0.70	•								
08IR A 60 IC908	5.00	0.500	1.500	16.00	48.00	8.24	0.05	0.50	0.70								•	
08IRM A 60 IC1007 ⁽¹⁾	5.00	0.500	1.500	16.00	48.00	8.24	0.05	0.60	0.70									•
08IRM A 60 IC228 ⁽¹⁾	5.00	0.500	1.500	16.00	48.00	8.24	0.05	0.60	0.70		•							
08IRM A 60 IC808 ⁽¹⁾	5.00	0.500	1.500	16.00	48.00	8.24	0.04	0.60	0.70						•			
08IRM A 60 IC908 ⁽¹⁾	5.00	0.500	1.500	16.00	48.00	8.24	0.05	0.60	0.70								•	
08UURL U 60 IC228	5.00	1.250	2.000	12.00	18.00	8.66	0.10	0.80	4.33		•							
11IL A 60 IC250	6.35	0.500	1.500	16.00	48.00	11.00	0.05	0.80	0.90				•					
11IL A 60 IC50M	6.35	0.500	1.500	16.00	48.00	11.00	0.05	0.80	0.90			•						
11IL A 60 IC908	6.35	0.500	1.500	16.00	48.00	11.00	0.05	0.80	0.90								•	
11IR A 60 IC08	6.35	0.500	1.500	16.00	48.00	11.00	0.05	0.80	0.90					•				
11IR A 60 IC1007	6.35	0.500	1.500	16.00	48.00	11.00	0.05	0.80	0.90									•
11IR A 60 IC228	6.35	0.500	1.500	16.00	48.00	11.00	0.05	0.80	0.90		•							
11IR A 60 IC250	6.35	0.500	1.500	16.00	48.00	11.00	0.05	0.80	0.90				•					
11IR A 60 IC50M	6.35	0.500	1.500	16.00	48.00	11.00	0.05	0.80	0.90			•						
11IR A 60 IC908	6.35	0.500	1.500	16.00	48.00	11.00	0.05	0.80	0.90								•	
11IRM A 60 IC1007 ⁽¹⁾	6.35	0.500	1.500	16.00	48.00	11.00	0.05	0.70	0.90									•
11IRM A 60 IC250 ⁽¹⁾	6.35	0.500	1.500	16.00	48.00	11.00	0.05	0.70	0.90				•					
11IRM A 60 IC808 ⁽¹⁾	6.35	0.500	1.500	16.00	48.00	11.00	0.05	0.70	0.90						•			
11IRM A 60 IC908 ⁽¹⁾	6.35	0.500	1.500	16.00	48.00	11.00	0.05	0.70	0.90								•	
16IL A 60 IC250	9.52	0.500	1.500	16.00	48.00	16.49	0.05	0.70	0.80				•					
16IL A 60 IC908	9.52	0.500	1.500	16.00	48.00	16.49	0.05	0.70	0.80								•	
16IR A 60 IC1007	9.52	0.500	1.500	16.00	48.00	16.49	0.05	0.80	0.90									•
16IR A 60 IC228	9.52	0.500	1.500	16.00	48.00	16.49	0.05	0.70	0.80		•							
16IR A 60 IC250	9.52	0.500	1.500	16.00	48.00	16.49	0.05	0.70	0.80				•					
16IR A 60 IC50M	9.52	0.500	1.500	16.00	48.00	16.49	0.05	0.70	0.80			•						
16IR A 60 IC908	9.52	0.500	1.500	16.00	48.00	16.49	0.05	0.70	0.80								•	
16IRB A 60 IC908 ⁽¹⁾	9.52	0.500	1.500	16.00	48.00	16.49	0.04	0.80	0.80								•	
16IRM A 60 IC1007 ⁽¹⁾	9.52	0.500	1.500	16.00	48.00	16.49	0.05	0.80	0.90									•
16IRM A 60 IC250 ⁽¹⁾	9.52	0.500	1.500	16.00	48.00	16.49	0.05	0.80	0.90				•					
16IRM A 60 IC808 ⁽¹⁾	9.52	0.500	1.500	16.00	48.00	16.49	0.05	0.80	0.90						•			
16IRM A 60 IC908 ⁽¹⁾	9.52	0.500	1.500	16.00	48.00	16.49	0.05	0.80	0.90								•	
16IL AG 60 IC1007	9.52	0.500	3.000	8.00	48.00	16.49	0.05	1.20	1.70									•
16IL AG 60 IC250	9.52	0.500	3.000	8.00	48.00	16.49	0.05	1.20	1.70				•					
16IL AG 60 IC908	9.52	0.500	3.000	8.00	48.00	16.49	0.05	1.20	1.70								•	
16IR AG 60 IC1007	9.52	0.500	3.000	8.00	48.00	16.49	0.05	1.20	1.70									•
16IR AG 60 IC228	9.52	0.500	3.000	8.00	48.00	16.49	0.05	1.20	1.70		•							
16IR AG 60 IC250	9.52	0.500	3.000	8.00	48.00	16.49	0.05	1.20	1.70				•					
16IR AG 60 IC50M	9.52	0.500	3.000	8.00	48.00	16.49	0.05	1.20	1.70			•						
16IR AG 60 IC508	9.52	0.500	3.000	8.00	48.00	16.49	0.05	1.20	1.70					•				
16IR AG 60 IC908	9.52	0.500	3.000	8.00	48.00	16.49	0.05	1.20	1.70								•	
16IRB AG 60 IC908 ⁽¹⁾	9.52	0.500	3.000	8.00	48.00	16.49	0.05	1.20	1.70								•	
16IRM AG 60 IC1007 ⁽¹⁾	9.52	0.500	3.000	8.00	48.00	16.49	0.05	1.20	1.70									•
16IRM AG 60 IC250 ⁽¹⁾	9.52	0.500	3.000	8.00	48.00	16.49	0.05	1.20	1.70				•					

• For Insert Identification System, see page 714 • For technical information and detailed cutting data, see pages 809-825

• DIN13, ISO 68-1, ISO 965 (1&2) - Internal tolerance: 6H

• ANSI/ASME B1.1 - Internal tolerance: 2B

⁽¹⁾ With a pressed chipformer

⁽²⁾ Thread pitch minimum (mm)

⁽³⁾ Thread pitch maximum (mm)

⁽⁴⁾ Threads per inch minimum

⁽⁵⁾ Threads per inch maximum

For tools, see pages: AVC-D-SIR/L (805) • C#-SIR/L (803) • MGSIR/L (156) • PICIN-A-SIR/L (466) • PICIN-MGSIR/L (466) • SIR/L (801)

Continued
ISCAR THREAD

IR/L-60°
Internal Laydown Threading
Inserts with a 60° Partial Profile
for General Applications

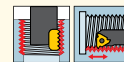
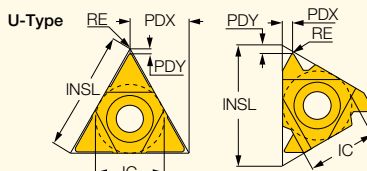

Internal left-hand shown

Designation	Dimensions									Tough ↔ Hard								
	IC	TPN ⁽²⁾	TPX ⁽³⁾	TPIN ⁽⁴⁾	TPIX ⁽⁵⁾	INSL	RE	PDY	PDX	IC28	IC228	IC50M	IC250	IC08	IC508	IC808	IC908	IC1007
16IRM AG 60 IC50M ⁽¹⁾	9.52	0.500	3.000	8.00	48.00	16.49	0.05	1.20	1.70			•						
16IRM AG 60 IC808 ⁽¹⁾	9.52	0.500	3.000	8.00	48.00	16.49	0.05	1.20	1.70							•		
16IRM AG 60 IC908 ⁽¹⁾	9.52	0.500	3.000	8.00	48.00	16.49	0.05	1.20	1.70								•	
16IL G 60 IC908	9.52	1.750	3.000	8.00	14.00	16.49	0.13	1.20	1.70									•
16IR G 60 IC08	9.52	1.750	3.000	8.00	14.00	16.49	0.13	1.20	1.70					•				
16IR G 60 IC1007	9.52	1.750	3.000	8.00	14.00	16.49	0.13	1.20	1.70									•
16IR G 60 IC228	9.52	1.750	3.000	8.00	14.00	16.49	0.13	1.20	1.70	•								
16IR G 60 IC250	9.52	1.750	3.000	8.00	14.00	16.49	0.13	1.20	1.70			•						
16IR G 60 IC50M	9.52	1.750	3.000	8.00	14.00	16.49	0.13	1.20	1.70			•						
16IR G 60 IC908	9.52	1.750	3.000	8.00	14.00	16.49	0.13	1.20	1.70									•
16IRB G 60 IC908 ⁽¹⁾	9.52	1.750	3.000	8.00	14.00	16.49	0.13	1.20	1.70									•
16IRM G 60 IC1007 ⁽¹⁾	9.52	1.750	3.000	8.00	14.00	16.49	0.10	1.20	1.70									•
16IRM G 60 IC250 ⁽¹⁾	9.52	1.750	3.000	8.00	14.00	16.49	0.10	1.20	1.70				•					
16IRM G 60 IC50M ⁽¹⁾	9.52	1.750	3.000	8.00	14.00	16.49	0.10	1.20	1.70			•						
16IRM G 60 IC808 ⁽¹⁾	9.52	1.750	3.000	8.00	14.00	16.49	0.10	1.20	1.70						•			
16IRM G 60 IC908 ⁽¹⁾	9.52	1.750	3.000	8.00	14.00	16.49	0.10	1.20	1.70									•
22IL N 60 IC908	12.70	3.500	5.000	5.00	7.00	22.00	0.22	1.70	2.50									•
22IR N 60 IC08	12.70	3.500	5.000	5.00	7.00	22.00	0.22	1.70	2.50					•				
22IR N 60 IC1007	12.70	3.500	5.000	5.00	7.00	22.00	0.22	1.70	2.50									•
22IR N 60 IC250	12.70	3.500	5.000	5.00	7.00	22.00	0.22	1.70	2.50				•					
22IR N 60 IC908	12.70	3.500	5.000	5.00	7.00	22.00	0.22	1.70	2.50									•
22IRM N 60 IC1007 ⁽¹⁾	12.70	3.500	5.000	5.00	7.00	22.00	0.19	1.70	2.50									•
22IRM N 60 IC250 ⁽¹⁾	12.70	3.500	5.000	5.00	7.00	22.00	0.19	1.70	2.50				•					
22IRM N 60 IC50M ⁽¹⁾	12.70	3.500	5.000	5.00	7.00	22.00	0.19	1.70	2.50			•						
22IRM N 60 IC808 ⁽¹⁾	12.70	3.500	5.000	5.00	7.00	22.00	0.19	1.70	2.50						•			
22IRM N 60 IC908 ⁽¹⁾	12.70	3.500	5.000	5.00	7.00	22.00	0.19	1.70	2.50									•
27IL Q 60 IC50M	15.88	5.500	6.000	4.00	4.50	27.50	0.40	1.90	2.40			•						
27IR Q 60 IC250	15.88	5.500	6.000	4.00	4.50	27.50	0.40	1.90	2.40				•					
27IR Q 60 IC908	15.88	5.500	6.000	4.00	4.50	27.50	0.40	1.90	2.40									•
16IL AG 60 IC08	9.52	0.500	3.000	8.00	48.00	16.49	0.05	1.20	1.70					•				

- For Insert Identification System, see page 714 • For technical information and detailed cutting data, see pages 809-825
- DIN13 , ISO 68-1, ISO 965 (1&2) - Internal tolerance: 6H
- ANSI/ASME B1.1 - Internal tolerance: 2B

- ⁽¹⁾ With a pressed chipformer
- ⁽²⁾ Thread pitch minimum (mm)
- ⁽³⁾ Thread pitch maximum (mm)
- ⁽⁴⁾ Threads per inch minimum
- ⁽⁵⁾ Threads per inch maximum

For tools, see pages: AVC-D-SIR/L (805) • C#-SIR/L (803) • MGSIR/L (156) • PICIN-A-SIR/L (466) • PICIN-MGSIR/L (466) • SIR/L (801)

PENTA 17-MT-RS/LS
Precision Ground Pentagonal
External Threading Inserts
with a 60° Partial Profile
for General Applications

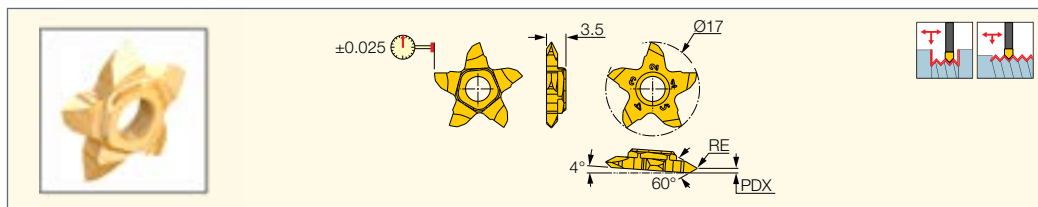

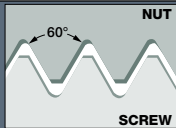
 Designation	Dimensions						IC1008
	TPIN ⁽¹⁾	TPIX ⁽²⁾	TPN ⁽³⁾	TPX ⁽⁴⁾	RE	PDX	
PENTA 17-MTL008LS IC1008	8.00	36.00	0.700	3.000	0.08	1.40	●
PENTA 17-MTR008RS IC1008	8.00	36.00	0.700	3.000	0.08	1.40	●
PENTA 17-MTL003LS IC1008	17.00	80.00	0.300	1.500	0.03	0.80	●
PENTA 17-MTR003RS IC1008	17.00	80.00	0.300	1.500	0.03	0.80	●

• DIN13 , ISO 68-1, ISO 965 (1&2) - External tolerance: 6g • ANSI/ASME B1.1 - External tolerance: 2A

(1) Threads per inch minimum

(2) Threads per inch maximum

(3) Thread pitch minimum (mm)

(4) Thread pitch maximum (mm)

For tools, see pages: NQCH-PCHR/L-S-JHP (433) • PCADRS/LS-JHP (354) • PCHRS/LS-17 (339) • PCHRS/LS-17-JHP (340) • Y-PCHRS-17 (340)

• Y-PCHRS-17-JHP (341)

PENTA 24-MT
Precision Ground Pentagonal
External Threading Inserts
with a 60° Partial Profile
for General Applications

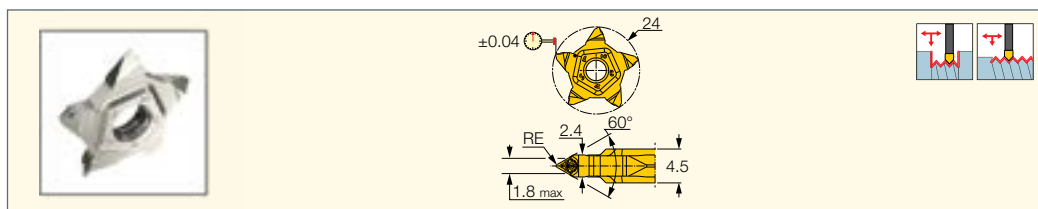

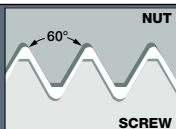
 Designation	Dimensions					IC908
	TPN ⁽²⁾	TPX ⁽³⁾	RE	TPIN ⁽⁴⁾	TPIX ⁽⁵⁾	
PENTA 24A-MT-0.05 IC908 (1)	0.250	3.000	0.05	8.00	80.00	●
PENTA 24-MT-0.05 IC908	0.250	3.500	0.05	8.00	80.00	●
PENTA 24N3-MT010RS IC908	0.500	3.500	0.10	7.00	48.00	●
PENTA 24A-MT-0.15 IC908	0.800	3.000	0.15	8.00	32.00	●

• TPX=0.175xD • DIN13 , ISO 68-1, ISO 965 (1&2) - External tolerance: 6g • ANSI/ASME B1.1 - External tolerance: 2A

(1) Flat rake (without a chipformer)

(2) Thread pitch minimum (mm)

(3) Thread pitch maximum (mm)

(4) Threads per inch minimum

(5) Threads per inch maximum

For tools, see pages: NQCH-PCHR/L-24-JHP (348) • PCAD RE/LE-JHP (561) • PCADR/L (353) • PCADR/L-JHP (353) • PCHBR/L (355)

• PCHR/L-24 (346) • PCHR/L-24-JHP (347) • PCHR/L-24-JHP-MC (348)



SCIR/L-22-MTR/MTL

Threading Inserts with a 60° Partial Profile

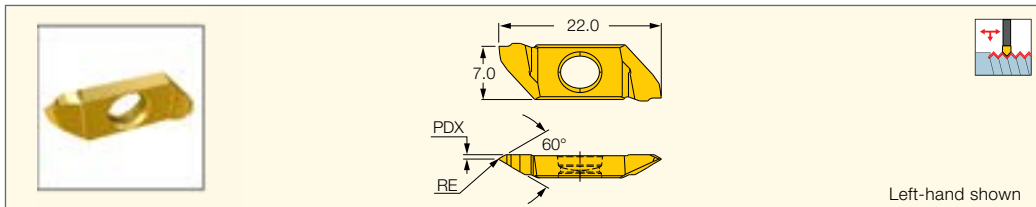

Left-hand shown

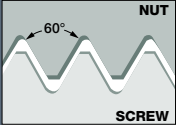
 Designation	Dimensions						Tough ← Hard		
	RE	PDX	TPN ⁽¹⁾	TPX ⁽²⁾	TPIX ⁽³⁾	TPIN ⁽⁴⁾	IC1008	IC07	IC1007
SCIL 22-MTL003 IC07	0.03	0.4	0.300	0.900	83.00	28.00		•	
SCIL 22-MTL003 IC1007	0.03	0.4	0.300	0.900	83.00	28.00	•		•
SCIL 22-MTL003 IC1008	0.03	0.4	0.300	0.900	83.00	28.00	•		
SCIR 22-MTR003 IC07	0.03	0.4	0.300	0.900	83.00	28.00		•	
SCIR 22-MTR003 IC1007	0.03	0.4	0.300	0.900	83.00	28.00		•	•
SCIR 22-MTR003 IC1008	0.03	0.4	0.300	0.900	83.00	28.00	•		
SCIL 22-MTL007 IC07	0.07	0.5	0.700	1.100	36.00	23.00		•	
SCIL 22-MTL007 IC1007	0.07	0.5	0.700	1.100	36.00	23.00	•		•
SCIL 22-MTR/L007 IC1008	0.07	0.5	0.700	1.100	36.00	23.00	•		
SCIR 22-MTR/L007 IC1008	0.07	0.5	0.700	1.100	36.00	23.00	•		
SCIR 22-MTR007 IC07	0.07	0.5	0.700	1.100	36.00	23.00		•	
SCIR 22-MTR007 IC1007	0.07	0.5	0.700	1.100	36.00	23.00		•	•
SCIL 22-MTL010 IC07	0.10	0.8	0.900	1.700	28.00	15.00		•	
SCIL 22-MTL010 IC1007	0.10	0.8	0.900	1.700	28.00	15.00	•		•
SCIL 22-MTL010 IC1008	0.10	0.8	0.900	1.700	28.00	15.00	•		
SCIR 22-MTR010 IC07	0.10	0.8	0.900	1.700	28.00	15.00		•	
SCIR 22-MTR010 IC1007	0.10	0.8	0.900	1.700	28.00	15.00		•	•
SCIR 22-MTR010 IC1008	0.10	0.8	0.900	1.700	28.00	15.00	•		•

- For detailed cutting data, see page 714 • DIN13 , ISO 68-1, ISO 965 (1&2) - External tolerance: 6g • ANSI/ASME B1.1 - External tolerance: 2A
- (1) Thread pitch minimum (mm)
- (2) Thread pitch maximum (mm)
- (3) Threads per inch maximum
- (4) Threads per inch minimum
- For tools, see pages: NQCH-SCHR/L-BF-JHP (408) • NQCH-Y-SCHR-BF-JHP (408) • SCHR/L-22BF (407) • SCHR/L-22BF-JHP (407) • Y-SCHR-22BF (407)
- Y-SCHR-22BF-JHP (408)



SCIR/L-41-MTR/MTL

Threading Inserts with a 60° Partial Profile

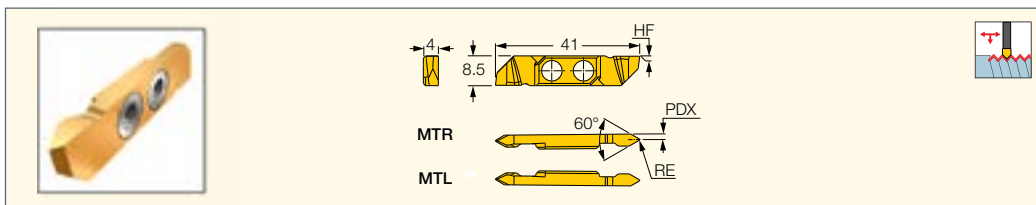

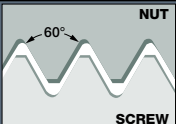
 Designation	Dimensions							IC1008
	RE	PDX	TPN ⁽¹⁾	TPX ⁽²⁾	TPIN ⁽³⁾	TPIX ⁽⁴⁾	HF ⁽⁵⁾	
SCIL 41-MTL006 IC1008	0.06	0.90	0.400	1.500	17.00	64.00	0.2	•
SCIR 41-MTR006 IC1008	0.06	0.90	0.400	1.500	17.00	64.00	0.2	•
SCIL 41-MTL020 IC1008	0.20	1.60	1.500	2.500	10.00	17.00	0.2	•
SCIR 41-MTR020 IC1008	0.20	1.60	1.500	2.500	10.00	17.00	0.2	•

- For detailed cutting data, see page 714 • DIN13 , ISO 68-1, ISO 965 (1&2) - External tolerance: 6g • ANSI/ASME B1.1 - External tolerance: 2A
- (1) Thread pitch minimum (mm)
- (2) Thread pitch maximum (mm)
- (3) Threads per inch minimum
- (4) Threads per inch maximum
- (5) Cutting edge below center
- For tools, see page: SCHR/L-41BF (412)

CUTGRIP
ISCARTHREAD

TIP-MT

Precision Ground Double-Ended Threading Inserts with a 60° Partial Profile and Chipformer

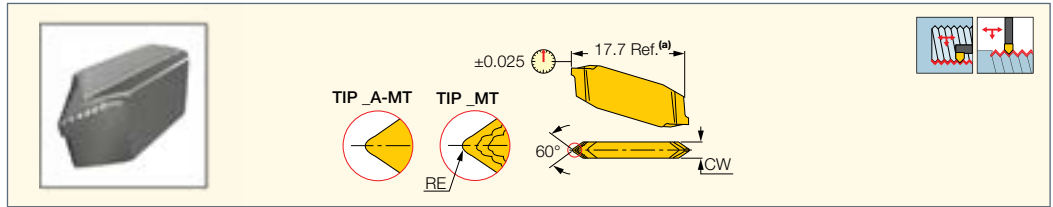

Designation	Dimensions							Tough ↔ Hard	
	CW	RE	RETOL ⁽²⁾	TPN ⁽³⁾	TPIX ⁽⁴⁾	TPIN ⁽⁵⁾	TPX ⁽⁶⁾	IC08	IC908
TIP 2A-MT-0.05 IC908 ⁽¹⁾	2.40	0.05	0.030	0.450	56.00	12.00	2.120	•	•
TIP 2MT-0.05 IC08	2.40	0.05	0.030	0.450	56.00	12.00	2.120	•	•
TIP 2MT-0.05 IC908	2.40	0.05	0.030	0.450	56.00	12.00	2.120	•	•
TIP 2MT-0.14 IC08	2.40	0.14	0.030	1.110	23.00	12.00	2.120	•	•
TIP 2MT-0.14 IC908	2.40	0.14	0.030	1.110	23.00	12.00	2.120	•	•
TIP 4A-MT-0.15 IC908 ⁽¹⁾	4.00	0.15	0.030	1.270	20.00	7.00	3.630	•	•
TIP 4MT-0.15 IC908	4.00	0.15	0.030	1.270	20.00	7.00	3.630	•	•
TIP 4MT-0.20 IC08	4.00	0.20	0.030	1.600	16.00	7.00	3.630	•	•
TIP 4MT-0.20 IC908	4.00	0.20	0.030	1.600	16.00	7.00	3.630	•	•
TIP 5MT-0.25 IC08	5.50	0.25	0.030	1.950	13.00	5.00	5.100	•	•
TIP 5MT-0.25 IC908	5.50	0.25	0.030	1.950	13.00	5.00	5.100	•	•

• (a) TIP inserts are 1.6 mm longer than GIP in the same pocket • Toolholder seat needs to be modified according to insert profile to ensure clearance
 • DIN13 , ISO 68-1, ISO 965 (1&2) - Internal tolerance: 6H, External tolerance: 6g • ANSI/ASME B1.1 - Internal tolerance: 2B, External tolerance: 2A

- (1) Without chipformer (flat rake)
- (2) Corner radius tolerance (+/-)
- (3) Thread pitch minimum (mm)
- (4) Threads per inch maximum
- (5) Threads per inch minimum
- (6) Thread pitch maximum (mm)

For tools, see pages: C#-GHDR/L (301) • CGHN 26-M (399) • CGHN 32-DGM (400) • CGHN 32-M (400) • CGHN-D (310) • CGHN-DG (310)
 • CGHN-S (309) • CGPAD (308) • CGPAD-JHP (309) • GHDR/L (short pocket) (302) • GHDR/L-JHP (short pocket) (303) • GHDR/L-JHP-MC (short pocket) (304)
 • GHGR/L (305) • GHMPR/L (300) • GHMR/L (300) • GHSR/L (428) • GHSR/L-JHP-SL (429) • NQCH-GHSR/L-JHP (428)

CUTGRIP
ISCARTHREAD

GEPI-MT

Precision Ground Internal Double-Ended Threading Inserts with a 60° Partial Profile for General Applications

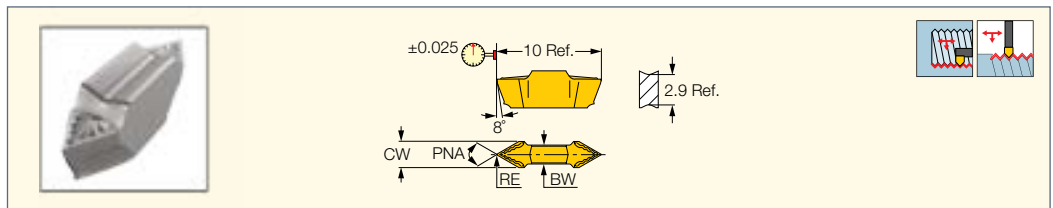

Designation	Dimensions									Tough ↔ Hard	
	CW	RE	RETOL ⁽¹⁾	PNA	BW	TPN ⁽²⁾	TPX ⁽³⁾	TPIN ⁽⁴⁾	TPIX ⁽⁵⁾	IC08	IC908
GEPI 2.5-MT0.05 IC08	2.50	0.05	0.030	60.0	1.80	0.910	2.540	10.00	28.00	•	•
GEPI 2.5-MT0.05 IC908	2.50	0.05	0.030	60.0	1.80	0.910	2.540	10.00	28.00	•	•

• Toolholder seat needs to be modified according to insert profile to ensure clearance • Pitch max 0.187xD, TPI min D/5.35
 • D=Diameter of thread (pitch max<=CW) • DIN13 , ISO 68-1, ISO 965 (1&2) - Internal tolerance: 6H, External tolerance: 6g
 • ANSI/ASME B1.1 - Internal tolerance: 2B, External tolerance: 2A

- (1) Corner radius tolerance (+/-)
- (2) Thread pitch minimum (mm)
- (3) Thread pitch maximum (mm)
- (4) Threads per inch minimum
- (5) Threads per inch maximum

For tools, see pages: AVC-GEAIR/L (389) • E-GEHIR / E-GHIR (383) • GEAIR/L (383) • GEHIRM/L (380) • GEHIRM/L-SC (380) • GEHIR/L (381)
 • GEHIR/L-SC (382) • GEHSR (427) • GEHSR/L-SL (426)

CUTGRIP
ISCARTHREAD

TIPI-MT

Precision Ground Double-Ended Internal Threading Inserts with 60° Partial Profile and Chipformer for 20mm Min. Bore Dia.

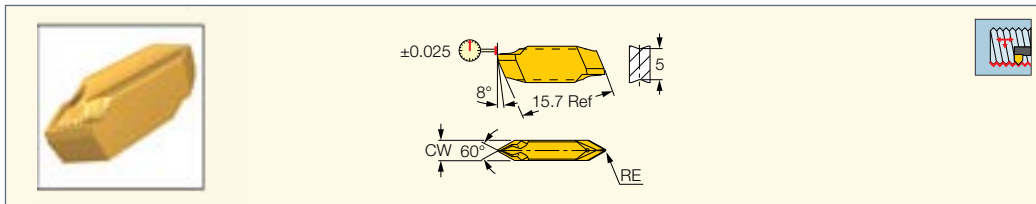

 Designation	Dimensions							Tough ↔ Hard	
	CW	RE	RETOL ⁽¹⁾	TPN ⁽²⁾	TPIX ⁽³⁾	TPIN ⁽⁴⁾	TPX ⁽⁵⁾	IC08	IC908
TIPI 3.4MT-0.10 IC08	3.40	0.10	0.030	1.800	14.00	8.00	3.180	●	
TIPI 3.4MT-0.10 IC908	3.40	0.10	0.030	1.800	14.00	8.00	3.180		●
TIPI 5.4MT-0.20 IC08	5.40	0.20	0.030	3.190	8.00	5.00	5.100	●	
TIPI 5.4MT-0.20 IC908	5.40	0.20	0.030	3.190	8.00	5.00	5.100		●

- Toolholder seat needs to be modified according to insert profile to ensure clearance. • Pitch max 0.205xD, TPI min D/4.8
- D=Diameter of thread (pitch max<=CW) • TIPI inserts are 1.6 mm longer than GIPI in the same pocket • DIN13 , ISO 68-1, ISO 965 (1&2) - Internal tolerance: 6H
- ANSI/ASME B1.1 - Internal tolerance: 2B
- (1) Corner radius tolerance (+/-)
- (2) Thread pitch minimum (mm)
- (3) Threads per inch maximum
- (4) Threads per inch minimum
- (5) Thread pitch maximum (mm)
- For tools, see pages:** AVC-GAIR/L (390) • CGIN 26 (391) • GAIR/L (389) • GHIR/L (W=1.9-6.4) (387) • GHIR/L-C (W=4-6.4) (387)
- GHIR/L-SC (W=2-4.8) (388)

NOTCHGRIP
GROOVE-TURN LINE
ISCARTHREAD

60° PARTIAL PROFILE THREADING FLT F

Double-Ended Precision Flat Top Threading Inserts

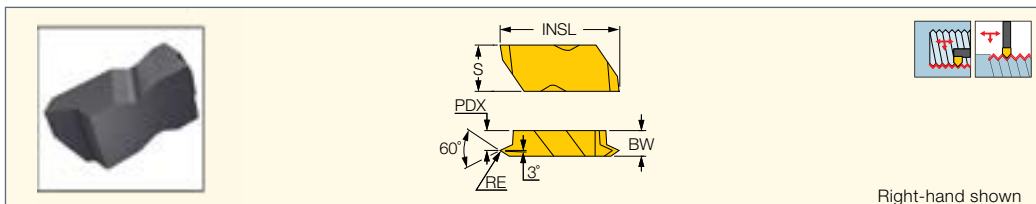

Right-hand shown

 Designation	Dimensions													IC908
	TPIN ⁽¹⁾	TPIX ⁽²⁾	TPIN_DF2 ⁽³⁾	TPIX_DF2 ⁽⁴⁾	RE	PDX	BW	S	INSL	TPN ⁽⁵⁾	TPX ⁽⁶⁾	TPN_DF2	TPX_DF2	
FLT F-2R/L IC908	12.00	24.00	14.00	44.00	0.08	2.80	3.81	5.56	12.95	1.000	2.000	0.500	1.750	●
FLT F-3R/L IC908	9.00	24.00	10.00	44.00	0.08	3.60	4.95	8.74	22.60	1.000	2.500	0.500	2.500	●
FLT F-4R/L IC908	9.00	24.00	10.00	44.00	0.08	5.10	6.48	11.51	28.45	1.000	2.500	0.500	2.500	●

- DMIN according to related boring bar • For 60° V-thread limits, see pages 822-823 • DIN13 , ISO 68-1, ISO 965 (1&2) - Internal tolerance: 6H, External tolerance: 6g
- ANSI/ASME B1.1 - Internal tolerance: 2B, External tolerance: 2A
- (1) TPI int. min.
- (2) TPI int. max.
- (3) TPI ext. min.
- (4) TPI ext. max.
- (5) Thread pitch minimum (mm)
- (6) Thread pitch maximum (mm)
- For tools, see pages:** FLASR/L (807) • FLSR/L (807)

**60° PARTIAL PROFILE
THREADING FLT-K**

Double-Ended Precision Positive
Rake Threading Inserts

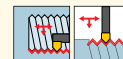
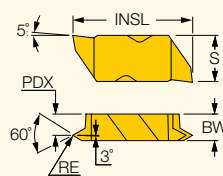

Right-hand shown

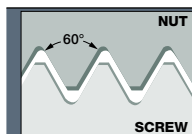

Dimensions

Designation	TPIN ⁽¹⁾	TPIX ⁽²⁾	TPN_ DF2 ⁽³⁾	TPIX_ DF2 ⁽⁴⁾	RE	TTP	PDX	BW	S	INSL	TPN ⁽⁵⁾	TPX ⁽⁶⁾	TPN_ DF2	TPX_ DF2	IC908
FLT-K-3R/L IC908	9.00	24.00	10.00	44.00	0.08	BOTH	3.60	4.95	8.74	22.60	1.000	2.500	0.500	2.500	●
FLT-K-4R/L IC908	9.00	24.00	10.00	44.00	0.08	BOTH	5.10	6.48	11.51	28.45	1.000	2.500	0.500	2.500	●
FLT-K-2R/L IC908	12.00	24.00	14.00	44.00	0.08	BOTH	2.80	3.81	5.56	12.95	1.000	2.000	0.500	1.750	●

- DMIN according to related boring bar
- For 60° V-thread limits, see pages 822-823
- DIN13, ISO 68-1, ISO 965 (1&2) - Internal tolerance: 6H, External tolerance: 6g
- ANSI/ASME B1.1 - Internal tolerance: 2B, External tolerance: 2A

- (1) TPI int. min.
- (2) TPI int. max.
- (3) TPI ext. min.
- (4) TPI ext. max.
- (5) Thread pitch minimum (mm)
- (6) Thread pitch maximum (mm)

For tools, see pages: FLASR/L (807) • FLSR/L (807)

**60° PARTIAL PROFILE
THREADING FLT-CB**

Double-Ended Precision
Threading Inserts with
Chipbreakers

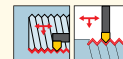
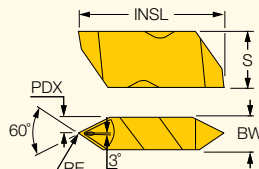

Right-hand shown

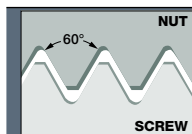

Dimensions

Designation	TPIN ⁽¹⁾	TPIX ⁽²⁾	TPN_ DF2 ⁽³⁾	TPIX_ DF2 ⁽⁴⁾	RE	PDX	BW	S	INSL	TPN ⁽⁵⁾	TPX ⁽⁶⁾	TPN_ DF2	TPX_ DF2	IC908
FLT-4R/L-HCB IC908	4.00	12.00	4.00	20.00	0.17	3.30	6.48	11.51	28.45	2.000	6.000	1.250	6.000	●
FLT-3R/LC-HCB IC908	5.00	6.00	6.00	11.00	0.34	2.50	4.95	8.74	22.60	4.000	5.000	2.250	4.000	●
FLT-3R/L-HCB IC908	5.00	12.00	6.00	20.00	0.17	2.50	4.95	8.74	22.60	2.000	5.000	1.250	4.000	●
FLT-3R/L-FCB IC908	7.00	20.00	8.00	36.00	0.10	2.50	4.95	8.74	22.60	1.250	3.500	0.500	3.000	●
FLT-3R/L-CB IC908	8.00	12.00	8.00	20.00	0.17	2.50	4.95	8.74	22.60	2.000	3.000	1.250	3.000	●

- DMIN according to related boring bar
- For 60° V-thread limits, see pages 822-823
- DIN13, ISO 68-1, ISO 965 (1&2) - Internal tolerance: 6H, External tolerance: 6g
- ANSI/ASME B1.1 - Internal tolerance: 2B, External tolerance: 2A

- (1) TPI int. min.
- (2) TPI int. max.
- (3) TPI ext. min.
- (4) TPI ext. max.
- (5) Thread pitch minimum (mm)
- (6) Thread pitch maximum (mm)

For tools, see pages: FLASR/L (807) • FLSR/L (807)

NOTCH-GRIP
GROOVE-TURN LINE
ISCARTHREAD

**60° PARTIAL PROFILE
THREADING FLT**

Double-Ended Precision Flat
Top Threading Inserts

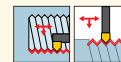
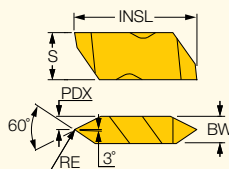

Right-hand shown

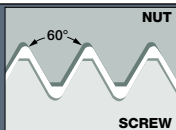

Dimensions

Designation	TPIN ⁽¹⁾	TPIX ⁽²⁾	TPIN_ DF2 ⁽³⁾	TPIX_ DF2 ⁽⁴⁾	RE	PDX	BW	S	INSL	TPN ⁽⁵⁾	TPX ⁽⁶⁾	TPN_ DF2	TPX_ DF2	IC908
FLT-4R/L IC908	4.00	12.00	4.00	20.00	0.17	3.30	6.48	11.51	28.45	2.000	6.000	1.250	6.000	●
FLT-3R/L IC908	5.00	12.00	6.00	20.00	0.26	2.50	4.95	8.74	22.60	2.000	5.000	1.250	4.000	●
FLT-3010R/L IC908	5.00	12.00	6.00	18.00	0.10	2.50	4.95	8.74	22.60	2.000	5.000	1.250	4.000	●
FLT-2R/L IC908	7.00	20.00	8.00	36.00	0.10	1.90	3.81	5.56	12.95	1.250	3.500	0.500	3.000	●

• DMIN according to related boring bar • For 60° V-thread limits, see pages 822-823 • DIN13 , ISO 68-1, ISO 965 (1&2) - Internal tolerance: 6H, External tolerance: 6g

• ANSI/ASME B1.1 - Internal tolerance: 2B, External tolerance: 2A

(1) TPI int. min.

(2) TPI int. max.

(3) TPI ext. min.

(4) TPI ext. max.

(5) Thread pitch minimum (mm)

(6) Thread pitch maximum (mm)

For tools, see pages: FLASR/L (807) • FLSR/L (807)

NOTCH-GRIP
GROOVE-TURN LINE
ISCARTHREAD

**60° PARTIAL PROFILE
THREADING FLTP**

Double-Ended Precision Positive
Rake Threading Inserts

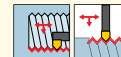
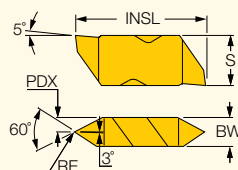

Right-hand shown

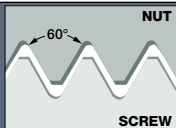

Dimensions

Designation	TPIN ⁽¹⁾	TPIX ⁽²⁾	TPIN_ DF2 ⁽³⁾	TPIX_ DF2 ⁽⁴⁾	RE	PDX	BW	S	INSL	TPN ⁽⁵⁾	TPX ⁽⁶⁾	TPN_ DF2	TPX_ DF2	IC908
FLTP-4R/L IC908	4.00	12.00	4.00	20.00	0.17	3.30	6.50	11.51	28.45	2.000	6.000	1.250	6.000	●
FLTP-3R/L IC908	5.00	12.00	6.00	20.00	0.17	2.50	5.00	8.74	22.60	2.000	5.000	1.250	4.000	●
FLTP-2R/L IC908	7.00	20.00	8.00	36.00	0.10	1.90	3.80	5.56	12.95	1.250	3.500	0.500	3.000	●

• DMIN according to related boring bar • For 60° V-thread limits, see pages 822-823 • DIN13 , ISO 68-1, ISO 965 (1&2) - Internal tolerance: 6H, External tolerance: 6g

• ANSI/ASME B1.1 - Internal tolerance: 2B, External tolerance: 2A

(1) TPI int. min.

(2) TPI int. max.

(3) TPI ext. min.

(4) TPI ext. max.

(5) Thread pitch minimum (mm)

(6) Thread pitch maximum (mm)

For tools, see pages: FLASR/L (807) • FLSR/L (807)

MITR 8-MT
Internal ISO Metric Threading
Inserts for Partial Profile

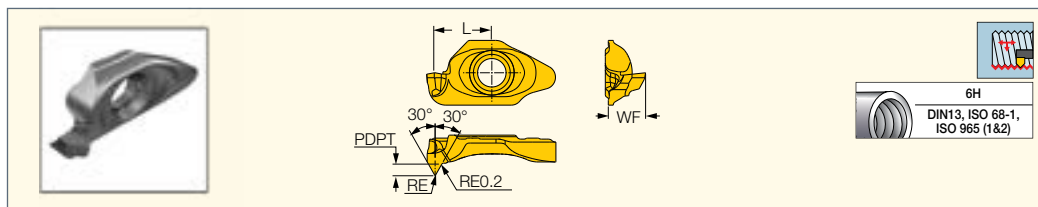

Designation	Dimensions							IC908
	PDPT ⁽¹⁾	RE	L	WF	DMIN ⁽²⁾	TPN ⁽³⁾	TPX ⁽⁴⁾	
MITR 8-MT2-0.1 IC908	1.17	0.10	5.75	3.80	10.00	1.500	2.000	•
MITR 8-MT1-0.05 IC908	1.23	0.05	5.75	3.80	10.00	0.750	1.250	•

(1) Cutting depth maximum
(2) Minimum diameter
(3) Thread pitch minimum (mm)
(4) Thread pitch maximum (mm)
For tools, see page: MIFHR (468)

MINICHAM
ISCARTHREAD

UMGR-A60
Mini Indexable Inserts with a
60° Partial Profile for Threading
in 5.2 mm and Larger Holes

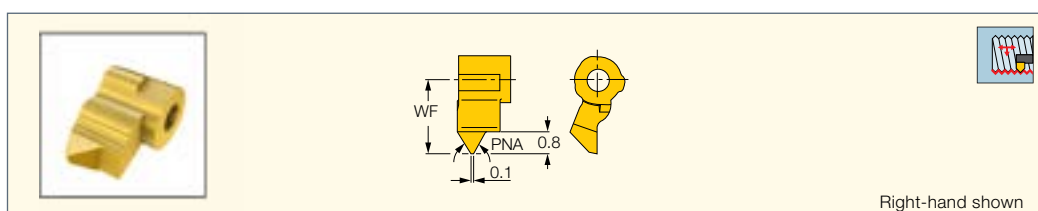

Designation	Dimensions							IC508
	PNA	WF	DMIN	TPN ⁽¹⁾	TPX ⁽²⁾	TPIN ⁽³⁾	TPIX ⁽⁴⁾	
UMGR 4.0-A60 IC508	60.0	2.70	5.20	0.600	1.250	20.00	40.00	•

• For detailed cutting data, see page 714 • DIN13 , ISO 68-1, ISO 965 (1&2) - Internal tolerance: 6H • ANSI/ASME B1.1 - Internal tolerance: 2B
(1) Thread pitch minimum (mm)
(2) Thread pitch maximum (mm)
(3) Threads per inch minimum
(4) Threads per inch maximum
For tools, see page: MIFHR (468)

CHAMGROOVE
ISCARTHREAD

GIQR/L-MT
Internal Threading Inserts with a
60° Partial Profile for Threading
in 8 mm and Larger Holes

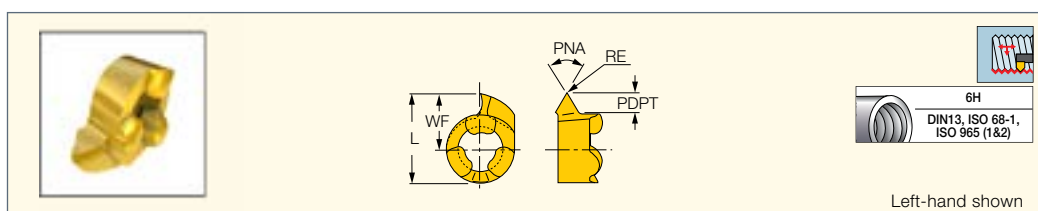

Designation	Dimensions										IC528
	L	RE	PNA	PDPT ⁽¹⁾	WF	DMIN ⁽²⁾	TPN ⁽³⁾	TPX ⁽⁴⁾	TPIN ⁽⁵⁾	TPIX ⁽⁶⁾	
GIQR/L 8-MT-0.05 IC528	7.78	0.05	60.0	1.50	4.80	8.00	0.500	1.590	16.00	50.00	•
GIQR/L 11-MT-0.05 IC528	10.68	0.05	60.0	2.00	6.70	11.00	0.500	2.300	11.00	50.00	•

• Can be used for thread milling by circular interpolation • Pitch max 0.19xD • D-diameter of thread • For cutting speed recommendations, see page 809
• DIN13 , ISO 68-1, ISO 965 (1&2) - Internal tolerance: 6H • ANSI/ASME B1.1 - Internal tolerance: 2B
(1) Cutting depth maximum
(2) Minimum diameter
(3) Thread pitch minimum (mm)
(4) Thread pitch maximum (mm)
(5) Threads per inch minimum
(6) Threads per inch maximum
For tools, see pages: MG (470) • MGCH (470)

PICCOJET
COOLANT THROUGH
ISCARTHREAD

PICJ R/LTH (60° Threading)
Inserts with a 60° Internal Thread Profile and Inner Coolant Channel for 2.4mm min. Bore Diameter

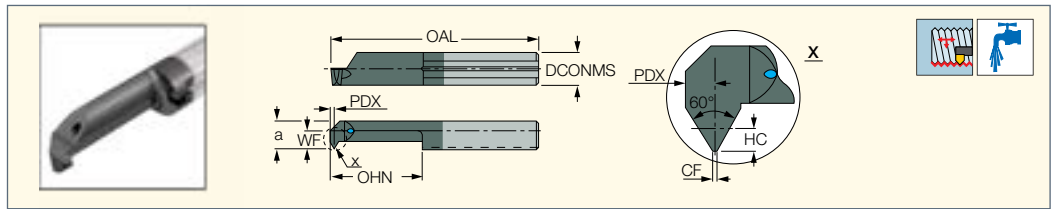

Designation	Dimensions													IC908
	DCONMS	DMIN	HC	CF	PDX	WF	a	OHN ⁽¹⁾	OAL	TPN ⁽²⁾	TPX ⁽³⁾	TPIN ⁽⁴⁾	TPIX ⁽⁵⁾	
PICJ RTH710.50D024	4.00	2.40	0.27	0.04	0.30	0.30	2.30	8.0	22.00	0.500	0.700	36.00	48.00	●
PICJ RTH910.50D032	4.00	3.20	0.27	0.09	0.40	1.00	3.00	10.0	24.00	0.500	0.750	36.00	48.00	●
PICJ RTH1410.50D040	4.00	4.00	0.27	0.06	0.40	1.50	3.50	15.0	30.00	0.500	0.750	36.00	48.00	●
PICJ RTH1410.50D050	5.00	5.00	0.27	0.06	0.40	1.90	4.40	15.0	30.00	0.500	0.750	36.00	48.00	●
PICJ RTH1410.75D050	5.00	5.00	0.40	0.09	0.50	1.90	4.40	15.0	30.00	0.750	1.000	24.00	36.00	●
PICJ R/LTH1411.00D048	5.00	4.80	0.55	0.12	0.60	1.90	4.40	15.0	30.00	1.000	1.250	20.00	24.00	●
PICJ RTH1911.00D048	5.00	4.80	0.55	0.12	0.60	1.90	4.40	20.0	35.00	1.000	1.250	20.00	24.00	●
PICJ RTH1411.00D060	6.00	6.00	0.55	0.12	0.60	2.30	5.30	15.0	30.00	1.000	1.250	20.00	24.00	●
PICJ RTH2111.00D060	6.00	6.00	0.55	0.12	0.60	2.30	5.30	22.0	37.00	1.000	1.250	20.00	24.00	●
PICJ RTH1411.25D060	6.00	6.00	0.68	0.15	0.70	2.30	5.30	15.0	30.00	1.250	1.500	16.00	20.00	●
PICJ RTH1411.50D060	6.00	6.00	0.81	0.18	0.80	2.30	5.30	15.0	30.00	1.500	1.750	14.00	16.00	●
PICJ R/LTH1411.5D070	7.00	7.00	0.81	0.18	0.80	2.70	6.30	15.0	30.00	1.500	1.750	14.00	16.00	●

NEW

- For detailed cutting data, see page 714 • DIN13 , ISO 68-1, ISO 965 (1&2) - Internal tolerance: 6H • ANSI/ASME B1.1 - Internal tolerance: 2B
- PICJ items are suitable for: PICCO ACE (440) • PICCO/MG PCO (Holder) (441) • SC-PICCO (420) type holders only

- (1) Minimum overhang
- (2) Thread pitch minimum (mm)
- (3) Thread pitch maximum (mm)
- (4) Threads per inch minimum
- (5) Threads per inch maximum

PICCO CUT
ISCARTHREAD

PICCO R/L-60°-Thread
Inserts with a 60° Internal Thread Profile for 2.4 mm Min. Bore Diameter

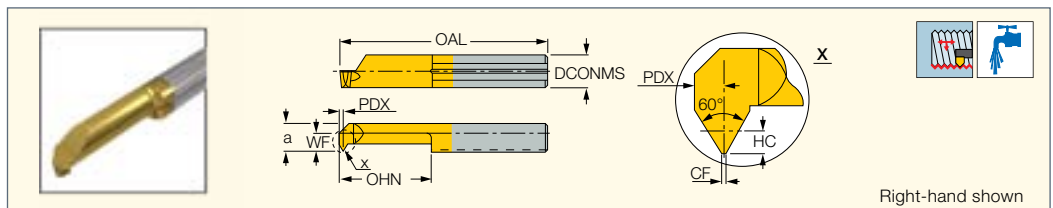

Designation	Dimensions													Tough ↔ Hard	
	DCONMS	DMIN	HC	CF	PDX	WF	a	OHN ⁽¹⁾	OAL	TPN ⁽²⁾	TPX ⁽³⁾	TPIN ⁽⁴⁾	TPIX ⁽⁵⁾	IC228	IC908
PICCO R 003.0105-8	4.00	2.40	0.27	0.04	0.30	0.30	2.30	8.0	22.00	0.500	0.700	36.00	48.00		●
PICCO R 004.0105-10	4.00	3.20	0.27	0.09	0.40	1.00	3.00	10.0	24.00	0.500	0.750	36.00	48.00		●
PICCO R/L 004.0205-15	4.00	4.00	0.27	0.06	0.40	1.50	3.50	15.0	30.00	0.500	0.750	36.00	48.00	●	
PICCO R/L 005.0205-15	5.00	5.00	0.27	0.06	0.40	1.90	4.40	15.0	30.00	0.500	0.750	36.00	48.00	●	
PICCO L 005.0407-15	5.00	5.00	0.40	0.09	0.50	1.90	4.40	15.0	30.00	0.750	1.000	24.00	36.00	●	
PICCO R 005.0407-15	5.00	5.00	0.40	0.09	0.50	1.90	4.40	15.0	30.00	0.750	1.000	24.00	36.00	●	●
PICCO R 005.0407-20	5.00	5.00	0.40	0.09	0.50	1.90	4.40	20.0	35.00	0.750	1.000	24.00	36.00	●	●
PICCO R/L 005.0510-15	5.00	4.80	0.55	0.12	0.60	1.90	4.40	15.0	30.00	1.000	1.250	20.00	24.00	●	
PICCO R 005.0510-20	5.00	4.80	0.55	0.12	0.60	1.90	4.40	20.0	35.00	1.000	1.250	20.00	24.00	●	●
PICCO R/L 006.0510-15	6.00	6.00	0.55	0.12	0.60	2.30	5.30	15.0	30.00	1.000	1.250	20.00	24.00	●	
PICCO R 006.0510-22	6.00	6.00	0.55	0.12	0.60	2.30	5.30	22.0	37.00	1.000	1.250	20.00	24.00	●	●
PICCO R/L 006.0612-15	6.00	6.00	0.68	0.15	0.70	2.30	5.30	15.0	30.00	1.250	1.500	16.00	20.00	●	
PICCO R 006.0612-22	6.00	6.00	0.68	0.15	0.70	2.30	5.30	22.0	37.00	1.250	1.500	16.00	20.00	●	●
PICCO R/L 006.0815-15	6.00	6.00	0.81	0.18	0.80	2.30	5.30	15.0	30.00	1.500	1.750	14.00	16.00	●	
PICCO R 006.0815-22	6.00	6.00	0.81	0.18	0.80	2.30	5.30	22.0	37.00	1.500	1.750	14.00	16.00	●	●
PICCO R/L 007.0815-15	7.00	7.00	0.81	0.18	0.80	2.70	6.30	15.0	30.00	1.500	1.750	14.00	16.00	●	

- For detailed cutting data, see page 714 • DIN13 , ISO 68-1, ISO 965 (1&2) - Internal tolerance: 6H • ANSI/ASME B1.1 - Internal tolerance: 2B

- (1) Minimum overhang
- (2) Thread pitch minimum (mm)
- (3) Thread pitch maximum (mm)
- (4) Threads per inch minimum
- (5) Threads per inch maximum

For holders, see pages: PICCO ACE (440) • PICCO/MG PCO (Holder) (441) • SC-PICCO (420)

PICCOMFT

PICCO-MFT

Solid Carbide Tools for Drilling, Facing, Internal / External Turning and Threading on Swiss and Small CNC Machines

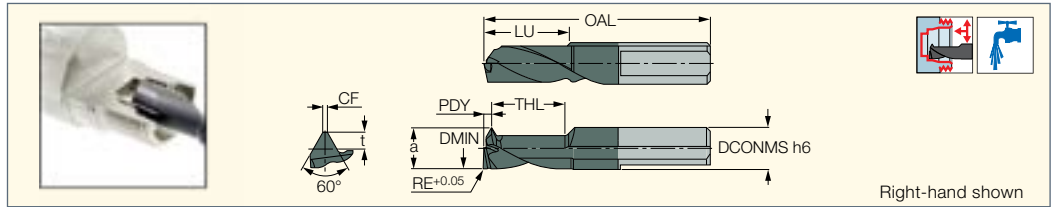

Right-hand shown

Designation	Dimensions														IC908
	DCONMS	DMIN	LU	TPN ⁽²⁾	TPX ⁽³⁾	TPIN ⁽⁴⁾	TPIX ⁽⁵⁾	t	a	CF	THL	OAL	PDY	RE	
PICCO R-MFT60 6-4 L08	6.00	4.00	8.00	0.500	0.750	32.00	48.00	0.46	3.90	0.06	7.3	30.00	1.30	0.10	●
PICCO R-MFT60 6-4 L12	6.00	4.00	12.00	0.500	0.750	32.00	48.00	0.46	3.90	0.06	11.6	34.00	1.20	0.20	●
PICCO R/L-MFT60 6-5 L10	6.00	5.00	10.00	0.500	1.000	24.00	48.00	0.61	4.90	0.06	9.0	32.00	1.40	0.10	●
PICCO R/L-MFT60 6-5 L15 ⁽¹⁾	6.00	5.00	15.00	0.500	1.000	24.00	48.00	0.61	4.90	0.06	14.4	37.00	1.40	0.30	●
PICCO R/L-MFT60 6-6 L18 ⁽¹⁾	6.00	6.00	18.00	0.500	1.000	24.00	48.00	0.61	5.90	0.06	17.3	43.00	1.40	0.30	●
PICCO R-MFT60 6-6 L12	6.00	6.00	12.00	0.500	1.000	24.00	48.00	0.61	5.90	0.06	11.0	34.00	1.40	0.10	●
PICCO R/L-MFT60 8-7 L14	8.00	7.00	14.00	0.750	1.250	20.00	32.00	0.76	6.90	0.09	13.0	41.00	1.50	0.10	●
PICCO R-MFT60 8-7 L21	8.00	7.00	21.00	0.750	1.250	20.00	32.00	0.76	6.90	0.09	20.0	55.00	1.50	0.30	●
PICCO R/L-MFT60 8-8 L16	8.00	8.00	16.00	0.900	1.500	16.00	28.00	0.92	7.90	0.11	15.0	43.00	1.50	0.10	●
PICCO L-MFT60 8-8 L24 ⁽¹⁾	8.00	8.00	24.00	0.900	1.500	16.00	28.00	0.92	7.90	0.11	23.0	57.00	1.50	0.30	●
PICCO R-MFT60 8-8 L24	8.00	8.00	24.00	0.900	1.500	16.00	28.00	0.92	7.90	0.11	23.0	51.00	1.50	0.30	●

• Applications: Drilling; face turning; internal chamfering; internal turning/boring; internal profiling; external chamfering; external turning; internal and external 60° threading (right- and left-hand)

• DIN13 , ISO 68-1, ISO 965 (1&2) - Internal tolerance: 6H, External tolerance: 6g • ANSI/ASME B1.1 - Internal tolerance: 2B, External tolerance: 2A

⁽¹⁾ Available on request

⁽²⁾ Thread pitch minimum (mm)

⁽³⁾ Thread pitch maximum (mm)

⁽⁴⁾ Threads per inch minimum

⁽⁵⁾ Threads per inch maximum

For holders, see page: PICCO/MG PCO (Holder) (399)

QUICKTHREAD

ER-ISO 3M-Q

External ISO Metric (DIN13 12-1986 class: 6g) Laydown Threading Inserts for General Applications

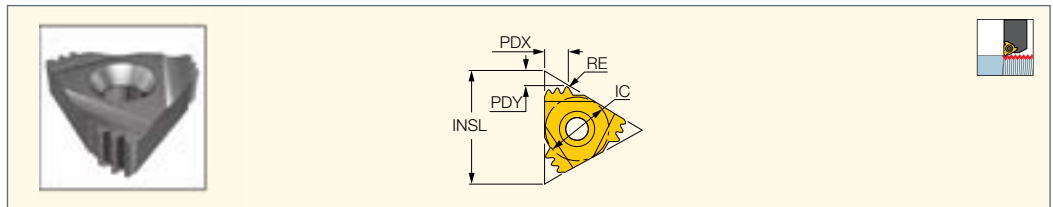

Designation	Dimensions							IC908
	IC	TP ⁽¹⁾	INSL	RE	PDX	PDY	CICT ⁽²⁾	
16ER 0.75 ISO 3M-Q IC908	9.53	0.750	16.00	0.12	1.90	1.40	3	●
16ER 1.00 ISO 3M-Q IC908	9.53	1.000	16.00	0.13	2.50	1.70	3	●
22ER 1.50 ISO 3M-Q IC908	12.70	1.500	22.00	0.23	3.70	2.40	3	●
22ER 2.00 ISO 3M-Q IC908	12.70	2.000	22.00	0.26	4.80	2.90	3	●

NEW

• For Insert Identification System, see page 714 • For threading between walls use GRIP-type inserts TIP-ISO class: 6g

• For technical information and detailed cutting data, see pages 809-825

⁽¹⁾ Thread pitch

⁽²⁾ Number of teeth per corner

For tools, see pages: C#-SER/L (799) • SER-D (800) • SER/L (798)

ISCAR THREAD

ER/L-ISO

External ISO Metric (DIN13 12-1986 class: 6g) Laydown Threading Inserts for General Applications

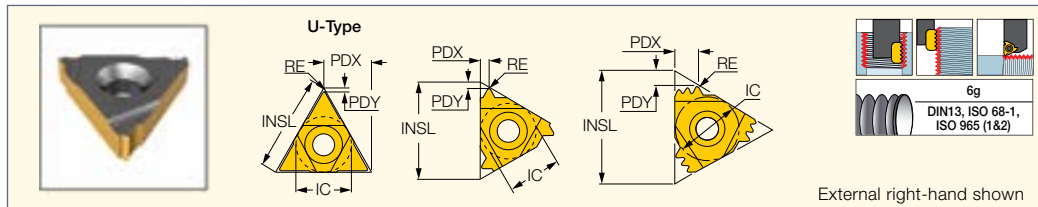

External right-hand shown

Designation	Dimensions							Tough ↔ Hard							
	IC	TP ⁽⁴⁾	INSL	RE	PDX	PDY	CICT ⁽⁵⁾	IC228	IC50M	IC250	IC08	IC508	IC908	IC908	IC1007
11EL 0.35 ISO IC908	6.35	0.350	11.00	0.04	0.40	0.80	1								•
11ER 0.35 ISO IC908	6.35	0.350	11.00	0.04	0.40	0.60	1								•
11ER 0.40 ISO IC908	6.35	0.400	11.00	0.04	0.40	0.70	1								•
11ER 0.45 ISO IC228	6.35	0.450	11.00	0.05	0.40	0.70	1	•							
11ER/L 0.50 ISO IC908	6.35	0.500	11.00	0.07	0.60	0.57	1								•
11ER 0.50 ISO IC250	6.35	0.500	11.00	0.07	0.60	0.57	1			•					
11ER 0.60 ISO IC908	6.35	0.600	11.00	0.07	0.60	0.60	1								•
11ER 0.70 ISO IC908	6.35	0.700	11.00	0.11	0.60	0.60	1								•
11EL 0.75 ISO IC908	6.35	0.750	11.00	0.08	0.60	0.60	1								•
11ER 0.75 ISO IC908	6.35	0.750	11.00	0.11	0.60	0.60	1								•
11ER 0.80 ISO IC908	6.35	0.800	11.00	0.12	0.60	0.60	1								•
11EL 1.00 ISO IC250	6.35	1.000	11.00	0.15	0.65	0.70	1			•					
11ER 1.00 ISO IC908	6.35	1.000	11.00	0.15	0.65	0.70	1								•
11ER 1.25 ISO IC908	6.35	1.250	11.00	0.16	0.90	0.80	1								•
11EL 1.50 ISO IC908	6.35	1.500	11.00	0.19	0.90	0.80	1								•
11ER 1.50 ISO IC250	6.35	1.500	11.00	0.19	0.80	1.00	1			•					
11ER 1.50 ISO IC908	6.35	1.500	11.00	0.19	0.80	1.00	1								•
11ER 1.75 ISO IC250	6.35	1.750	11.00	0.22	0.80	1.10	1			•					
16ER/L 0.35 ISO IC908	9.52	0.350	16.49	0.04	0.40	0.60	1								•
16EL 0.40 ISO IC908	9.52	0.400	16.49	0.05	0.40	0.70	1								•
16ER 0.40 ISO IC908	9.52	0.400	16.49	0.05	0.40	0.60	1								•
16ER 0.45 ISO IC908	9.52	0.450	16.49	0.05	0.40	0.60	1								•
16ER/L 0.50 ISO IC908	9.52	0.500	16.49	0.07	0.45	0.60	1								•
16ER 0.50 ISO IC08	9.52	0.500	16.49	0.07	0.45	0.60	1				•				
16ER 0.50 ISO IC1007	9.52	0.500	16.49	0.07	0.45	0.60	1								•
16ER 0.50 ISO IC250	9.52	0.500	16.49	0.07	0.45	0.60	1			•					
16ERM 0.50 ISO IC908	9.52	0.500	16.49	0.06	0.60	0.60	1								•
16ER 0.60 ISO IC908	9.52	0.600	16.49	0.10	0.60	0.60	1								•
16ER/L 0.70 ISO IC908	9.52	0.700	16.49	0.11	0.60	0.60	1								•
16ER 0.70 ISO IC1007	9.52	0.700	16.49	0.11	0.60	0.60	1								•
16ER 0.70 ISO IC250	9.52	0.700	16.49	0.11	0.60	0.60	1			•					
16ER/L 0.75 ISO IC908	9.52	0.750	16.49	0.11	0.60	0.60	1								•
16ER 0.75 ISO IC08	9.52	0.750	16.49	0.11	0.60	0.60	1				•				
16ER 0.75 ISO IC1007	9.52	0.750	16.49	0.11	0.60	0.60	1								•
16ER 0.75 ISO IC250	9.52	0.750	16.49	0.11	0.60	0.60	1			•					
16ER 0.75 ISO 3M IC908 (1)	9.52	0.750	16.49	0.07	1.90	1.40	3								•
16ERM 0.75 ISO IC1007	9.52	0.750	16.49	0.08	0.60	0.60	1								•
16ERM 0.75 ISO IC808 (2)	9.52	0.750	16.49	0.08	0.60	0.60	1						•		
16ERM 0.75 ISO IC908 (2)	9.52	0.750	16.49	0.08	0.60	0.60	1								•
16EL 0.80 ISO IC250	9.52	0.800	16.49	0.12	0.60	0.60	1			•					
16ER 0.80 ISO IC1007	9.52	0.800	16.49	0.12	0.60	1.00	1								•
16ER 0.80 ISO IC250	9.52	0.800	16.49	0.12	0.60	1.00	1			•					
16ER 0.80 ISO IC908	9.52	0.800	16.49	0.12	0.60	1.00	1								•
16ERB 0.80 ISO IC908 (2)	9.52	0.800	16.49	0.12	0.70	0.70	1								•
16EL 1.00 ISO IC08	9.52	1.000	16.49	0.15	0.80	0.70	1				•				
16ER/L 1.00 ISO IC250	9.52	1.000	16.49	0.15	0.75	0.70	1			•					
16EL 1.00 ISO IC908	9.52	1.000	16.49	0.15	0.75	0.70	1								•
16ER 1.00 ISO IC08	9.52	1.000	16.49	0.15	0.70	1.00	1				•				
16ER 1.00 ISO IC1007	9.52	1.000	16.49	0.15	0.70	1.00	1								•
16ER 1.00 ISO IC228	9.52	1.000	16.49	0.15	0.75	1.00	1	•							
16ER 1.00 ISO IC50M	9.52	1.000	16.49	0.15	0.75	0.70	1		•						
16ER 1.00 ISO IC908	9.52	1.000	16.49	0.15	0.70	1.00	1								•
16ER 1.00 ISO 3M IC908 (1)	9.52	1.000	16.49	0.07	2.50	1.70	3								•
16ERB 1.00 ISO IC908 (2)	9.52	1.000	16.49	0.15	0.70	0.70	1								•
16ERM 1.00 ISO IC1007 (2)	9.52	1.000	16.49	0.11	0.70	0.70	1								•

• For Insert Identification System, see page 714 • For threading between walls use GRIP-type inserts TIP-ISO class: 6g

• For technical information and detailed cutting data, see pages 809-825

(1) Multi-tooth

(2) With pressed chipformer

(3) With pressed chipformer

(4) Thread pitch

(5) Number of teeth per corner

For tools, see pages: C#-SER/L (799) • NQCH-SER/L-JHP (800) • SBTT#-16ER/L-JHP (418) • SER-D (800) • SER/L (798) • SER/L-JHP (799) • SER/L-JHP-MC (800)

ER/L-ISO

External ISO Metric (DIN13 12-1986 class: 6g) Laydown Threading Inserts for General Applications

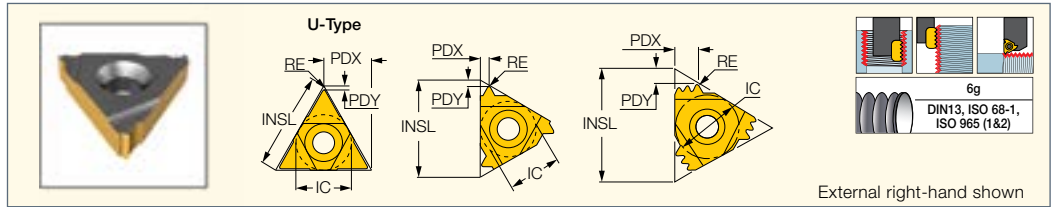

Designation	Dimensions							Tough ↔ Hard							
	IC	TP ⁽⁴⁾	INSL	RE	PDX	PDY	CICT ⁽⁵⁾	IC228	IC50M	IC250	IC08	IC508	IC808	IC908	IC1007
16ERM 1.00 ISO IC250 ⁽²⁾	9.52	1.000	16.49	0.11	0.70	0.70	1			•					
16ERM 1.00 ISO IC50M ⁽²⁾	9.52	1.000	16.49	0.11	0.70	0.70	1		•						
16ERM 1.00 ISO IC508 ⁽²⁾	9.52	1.000	16.49	0.11	0.70	0.70	1					•			
16ERM 1.00 ISO IC808 ⁽²⁾	9.52	1.000	16.49	0.11	0.70	0.70	1						•		
16ERM 1.00 ISO IC908 ⁽²⁾	9.52	1.000	16.49	0.11	0.70	0.70	1							•	
16ER/L 1.25 ISO IC08	9.52	1.250	16.49	0.16	0.90	0.80	1				•				
16ER/L 1.25 ISO IC250	9.52	1.250	16.49	0.16	0.90	0.80	1			•					
16ER/L 1.25 ISO IC908	9.52	1.250	16.49	0.16	0.90	0.80	1							•	
16ER 1.25 ISO IC1007	9.52	1.250	16.49	0.16	0.90	0.80	1								•
16ERB 1.25 ISO IC908 ⁽²⁾	9.52	1.250	16.49	0.16	0.90	0.80	1							•	
16ERM 1.25 ISO IC1007 ⁽²⁾	9.52	1.250	16.49	0.14	0.90	0.80	1								•
16ERM 1.25 ISO IC250 ⁽²⁾	9.52	1.250	16.49	0.14	0.90	0.80	1			•					
16ERM 1.25 ISO IC808 ⁽²⁾	9.52	1.250	16.49	0.14	0.90	0.80	1						•		
16ERM 1.25 ISO IC908 ⁽²⁾	9.52	1.250	16.49	0.14	0.90	0.80	1							•	
16ER/L 1.50 ISO IC08	9.52	1.500	16.49	0.22	1.15	1.00	1				•				
16EL 1.50 ISO IC1007	9.52	1.500	16.49	0.22	1.15	1.00	1								•
16EL 1.50 ISO IC250	9.52	1.500	16.49	0.22	1.20	1.00	1			•					
16ER/L 1.50 ISO IC908	9.52	1.500	16.49	0.22	1.15	1.00	1							•	
16ER 1.50 ISO IC1007	9.52	1.500	16.49	0.19	1.15	0.90	1								•
16ER 1.50 ISO IC228	9.52	1.500	16.49	0.19	1.20	0.90	1	•							
16ER 1.50 ISO IC250	9.52	1.500	16.49	0.19	1.20	0.90	1			•					
16ER 1.50 ISO IC50M	9.52	1.500	16.49	0.19	1.20	0.90	1		•						
16ER 1.50 ISO 2M IC908 ⁽¹⁾	9.52	1.500	16.49	0.18	2.30	1.50	2							•	
16ERB 1.50 ISO IC908 ⁽²⁾	9.52	1.500	16.49	0.19	1.00	0.80	1							•	
16ERM 1.50 ISO IC1007 ⁽²⁾	9.52	1.500	16.49	0.19	1.00	0.80	1								•
16ERM 1.50 ISO IC250 ⁽²⁾	9.52	1.500	16.49	0.19	1.00	0.80	1			•					
16ERM 1.50 ISO IC508 ⁽²⁾	9.52	1.500	16.49	0.19	1.00	0.80	1					•			
16ERM 1.50 ISO IC808 ⁽²⁾	9.52	1.500	16.49	0.19	1.00	0.80	1						•		
16ERM 1.50 ISO IC908 ⁽²⁾	9.52	1.500	16.49	0.19	1.00	0.80	1							•	
16EL 1.75 ISO IC908	9.52	1.750	16.49	0.26	1.15	1.10	1							•	
16ER 1.75 ISO IC08	9.52	1.750	16.49	0.26	1.20	1.00	1				•				
16ER 1.75 ISO IC1007	9.52	1.750	16.49	0.26	1.20	1.00	1								•
16ER 1.75 ISO IC228	9.52	1.750	16.49	0.26	1.15	1.10	1	•							
16ER 1.75 ISO IC250	9.52	1.750	16.49	0.26	1.15	1.10	1			•					
16ER 1.75 ISO IC908	9.52	1.750	16.49	0.26	1.20	1.00	1							•	
16ERB 1.75 ISO IC908 ⁽²⁾	9.52	1.750	16.49	0.26	1.15	1.00	1							•	
16ERM 1.75 ISO IC1007 ⁽²⁾	9.52	1.750	16.49	0.25	1.20	0.90	1							•	
16ERM 1.75 ISO IC250 ⁽²⁾	9.52	1.750	16.49	0.25	1.20	0.90	1			•					
16ERM 1.75 ISO IC808 ⁽²⁾	9.52	1.750	16.49	0.25	1.20	0.90	1						•		
16ERM 1.75 ISO IC908 ⁽²⁾	9.52	1.750	16.49	0.25	1.20	0.90	1							•	
16EL 2.00 ISO IC228	9.52	2.000	16.49	0.25	1.30	1.00	1	•							
16EL 2.00 ISO IC250	9.52	2.000	16.49	0.25	1.30	1.00	1			•					
16EL 2.00 ISO IC908	9.52	2.000	16.49	0.25	1.30	1.00	1							•	
16ER 2.00 ISO IC08	9.52	2.000	16.49	0.26	1.25	1.00	1				•				
16ER 2.00 ISO IC1007	9.52	2.000	16.49	0.26	1.25	1.00	1								•
16ER 2.00 ISO IC228	9.52	2.000	16.49	0.26	1.30	1.00	1	•							
16ER 2.00 ISO IC250	9.52	2.000	16.49	0.26	1.30	1.00	1			•					
16ER 2.00 ISO IC50M	9.52	2.000	16.49	0.26	1.30	1.00	1		•						
16ER 2.00 ISO IC908	9.52	2.000	16.49	0.26	1.25	1.00	1							•	
16ER 2.00 ISO 2M IC908 ⁽¹⁾	9.52	2.000	16.49	0.09	2.90	1.80	2							•	
16ERB 2.00 ISO IC908 ⁽²⁾	9.52	2.000	16.49	0.25	1.20	0.90	1							•	
16ERM 2.00 ISO IC1007 ⁽²⁾	9.52	2.000	16.49	0.28	1.30	1.00	1								•
16ERM 2.00 ISO IC250 ⁽²⁾	9.52	2.000	16.49	0.28	1.30	1.00	1			•					
16ERM 2.00 ISO IC508 ⁽²⁾	9.52	2.000	16.49	0.28	1.30	1.00	1					•			

• For Insert Identification System, see page 714 • For threading between walls use GRIP-type inserts TIP-ISO class: 6g

• For technical information and detailed cutting data, see pages 809-825

⁽¹⁾ Multi-tooth

⁽²⁾ With pressed chipformer

⁽³⁾ With pressed chipformer

⁽⁴⁾ Thread pitch

⁽⁵⁾ Number of teeth per corner

For tools, see pages: C#-SER/L (799) • NQCH-SER/L-JHP (800) • SBTT#-16ER/L-JHP (418) • SER-D (800) • SER/L (798) • SER/L-JHP (799) • SER/L-JHP-MC (800)

Continued

ISCAR THREAD

ER/L-ISO

External ISO Metric (DIN13 12-1986 class: 6g) Laydown Threading Inserts for General Applications

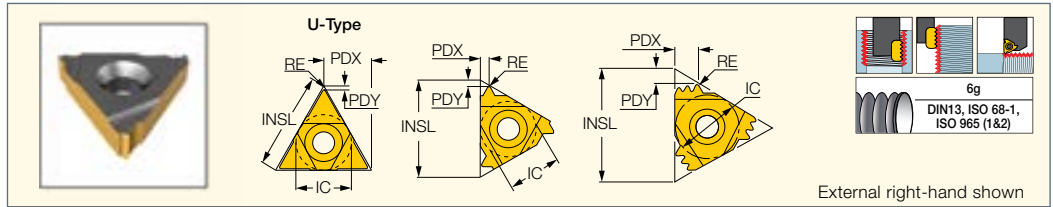

External right-hand shown

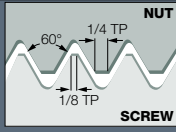

Designation	Dimensions							Tough ↔ Hard							
	IC	TP ⁽⁴⁾	INSL	RE	PDX	PDY	CICT ⁽⁵⁾	IC228	IC50M	IC250	IC08	IC508	IC808	IC908	IC1007
16ERM 2.00 ISO IC808 ⁽²⁾	9.52	2.000	16.49	0.28	1.30	1.00	1							•	
16ERM 2.00 ISO IC908 ⁽³⁾	9.52	2.000	16.49	0.28	1.30	1.00	1								•
16ER/L 2.50 ISO IC908	9.52	2.500	16.49	0.32	1.50	1.10	1								•
16ER 2.50 ISO IC1007	9.52	2.500	16.49	0.32	1.50	1.10	1								•
16ER 2.50 ISO IC250	9.52	2.500	16.49	0.32	1.50	1.10	1			•					
16ER 2.50 ISO IC50M	9.52	2.500	16.49	0.32	1.50	1.10	1		•						
16ERB 2.50 ISO IC908	9.52	2.500	16.49	0.32	1.50	1.10	1								•
16ERM 2.50 ISO IC1007 ⁽²⁾	9.52	2.500	16.49	0.30	1.50	1.10	1								•
16ERM 2.50 ISO IC250 ⁽²⁾	9.52	2.500	16.49	0.30	1.50	1.10	1			•					
16ERM 2.50 ISO IC808 ⁽²⁾	9.52	2.500	16.49	0.30	1.50	1.10	1						•		
16ERM 2.50 ISO IC908 ⁽²⁾	9.52	2.500	16.49	0.30	1.50	1.10	1							•	
16EL 3.00 ISO IC908	9.52	3.000	16.49	0.44	1.60	1.20	1								•
16ER 3.00 ISO IC1007	9.52	3.000	16.49	0.44	1.65	1.00	1								•
16ER 3.00 ISO IC228	9.52	3.000	16.49	0.44	1.60	1.20	1	•							
16ER 3.00 ISO IC250	9.52	3.000	16.49	0.44	1.60	1.20	1			•					
16ER 3.00 ISO IC50M	9.52	3.000	16.49	0.44	1.60	1.20	1		•						
16ER 3.00 ISO IC508	9.52	3.000	16.49	0.44	1.60	1.20	1					•			
16ER 3.00 ISO IC908	9.52	3.000	16.49	0.44	1.65	1.00	1							•	
16ERB 3.00 ISO IC908 ⁽²⁾	9.52	3.000	16.49	0.44	1.60	1.20	1							•	
16ERM 3.00 ISO IC1007 ⁽²⁾	9.52	3.000	16.49	0.38	1.60	1.20	1								•
16ERM 3.00 ISO IC250 ⁽²⁾	9.52	3.000	16.49	0.38	1.60	1.20	1			•					
16ERM 3.00 ISO IC50M ⁽²⁾	9.52	3.000	16.49	0.38	1.60	1.20	1		•						
16ERM 3.00 ISO IC508 ⁽²⁾	9.52	3.000	16.49	0.38	1.60	1.20	1					•			
16ERM 3.00 ISO IC808 ⁽²⁾	9.52	3.000	16.49	0.38	1.60	1.20	1						•		
16ERM 3.00 ISO IC908 ⁽²⁾	9.52	3.000	16.49	0.38	1.60	1.20	1							•	
16ERB 3.50 ISO IC908	9.52	3.500	16.49	0.51	1.60	1.30	1								•
22ER 1.50 ISO 3M IC250 ⁽¹⁾	12.70	1.500	22.00	0.18	3.70	2.30	3			•					
22ER 1.50 ISO 3M IC908 ⁽¹⁾	12.70	1.500	22.00	0.07	3.70	2.30	3								•
22ER 2.00 ISO 2M IC908 ⁽¹⁾	12.70	2.000	22.00	0.25	3.00	2.00	2								•
22ER 2.00 ISO 3M IC250 ⁽¹⁾	12.70	2.000	22.00	0.25	5.00	3.10	3			•					
22ER 2.00 ISO 3M IC908 ⁽¹⁾	12.70	2.000	22.00	0.25	5.00	3.10	3								•
22EL 3.50 ISO IC228	12.70	3.500	22.00	0.46	2.30	1.60	1	•							
22ER/L 3.50 ISO IC250	12.70	3.500	22.00	0.46	2.30	1.60	1			•					
22ER 3.50 ISO IC908	12.70	3.500	22.00	0.46	2.30	1.60	1								•
22ERM 3.50 ISO IC808 ⁽²⁾	12.70	3.500	22.00	0.48	2.30	1.60	1						•		
22ERM 3.50 ISO IC908 ⁽²⁾	12.70	3.500	22.00	0.48	2.30	1.60	1							•	
22ER/L 4.00 ISO IC250	12.70	4.000	22.00	0.52	2.30	1.60	1			•					
22ER/L 4.00 ISO IC908	12.70	4.000	22.00	0.52	2.30	1.60	1								•
22ER 4.00 ISO IC1007	12.70	4.000	22.00	0.52	2.30	1.60	1								•
22ER 4.00 ISO IC50M	12.70	4.000	22.00	0.52	2.30	1.60	1		•						
22ERM 4.00 ISO IC808 ⁽²⁾	12.70	4.000	22.00	0.52	2.30	1.60	1						•		
22ERM 4.00 ISO IC908 ⁽²⁾	12.70	4.000	22.00	0.52	2.30	1.60	1							•	
22ER 4.50 ISO IC250	12.70	4.500	22.00	0.58	2.30	1.60	1			•					
22ER 4.50 ISO IC908	12.70	4.500	22.00	0.58	2.30	1.60	1								•
22ER/L 5.00 ISO IC250	12.70	5.000	22.00	0.66	2.50	1.70	1			•					
22ER 5.00 ISO IC908	12.70	5.000	22.00	0.66	2.50	1.70	1								•
22UERL 5.50 ISO IC250	12.70	5.500	22.00	0.80	11.00	1.90	1			•					
22ER/L 6.00 ISO IC250	12.70	6.000	22.00	0.87	2.70	1.80	1			•					
22UERL 6.00 ISO IC228	12.70	6.000	22.00	0.78	11.00	2.60	1	•							
22UERL 6.00 ISO IC250	12.70	6.000	22.00	0.78	11.00	2.60	1			•					
27ER 3.00 ISO 2M IC908 ⁽¹⁾	15.88	3.000	27.50	0.38	4.60	2.90	2								•
27ER 5.50 ISO IC908	15.88	5.500	27.50	0.71	2.90	2.00	1								•
27ER/L 6.00 ISO IC908	15.88	6.000	27.50	0.87	2.90	2.00	1								•
27ER 6.00 ISO IC228	15.88	6.000	27.50	0.87	2.90	2.00	1	•							
27ER 6.00 ISO IC250	15.88	6.000	27.50	0.87	2.90	2.00	1			•					
27UERL 8.00 ISO IC908	15.88	8.000	27.50	1.08	13.70	2.40	1								•

• For Insert Identification System, see page 714 • For threading between walls use GRIP-type inserts TIP-ISO class: 6g
 • For technical information and detailed cutting data, see pages 809-825

⁽¹⁾ Multi-tooth
⁽²⁾ With pressed chipformer
⁽³⁾ With pressed chipformer
⁽⁴⁾ Thread pitch
⁽⁵⁾ Number of teeth per corner

For tools, see pages: C#-SER/L (799) • NQCH-SER/L-JHP (800) • SBTT#-16ER/L-JHP (418) • SER-D (800) • SER/L (798) • SER/L-JHP (799) • SER/L-JHP-MC (800)

IR/L-ISO
Internal ISO Metric (DIN13
12-1986 class 6H) Laydown
Threading Inserts for
General Applications

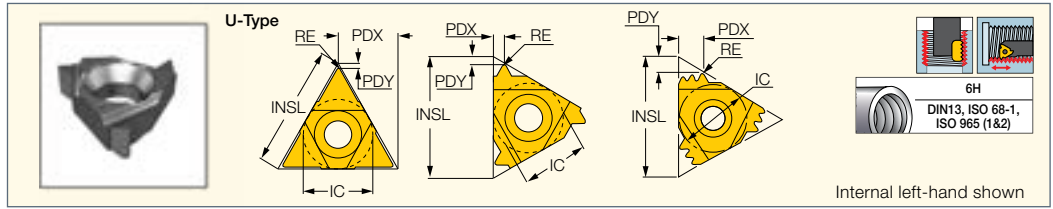

Designation	Dimensions							Tough ↔ Hard									
	IC	TP ⁽³⁾	INSL	RE	PDX	PDY	CICT ⁽⁴⁾	IC28	IC228	IC928	IC50M	IC250	IC08	IC508	IC808	IC908	IC1007
06IL 0.50 ISO IC228	4.00	0.500	6.88	0.04	0.40	0.60	1		•								
06IR 0.50 ISO IC228	4.00	0.500	6.88	0.04	0.40	0.60	1		•								
06IR 0.50 ISO IC908	4.00	0.500	6.88	0.04	0.40	0.60	1									•	
06IR 0.50 ISO IC928	4.00	0.500	6.88	0.04	0.40	0.60	1			•							
06IL 0.75 ISO IC228	4.00	0.750	6.88	0.06	0.50	0.60	1		•								
06IR 0.75 ISO IC228	4.00	0.750	6.88	0.06	0.50	0.60	1		•								
06IR 0.75 ISO IC908	4.00	0.750	6.88	0.06	0.50	0.60	1									•	
06IR 0.75 ISO IC928	4.00	0.750	6.88	0.06	0.50	0.60	1			•							
06IL 1.00 ISO IC228	4.00	1.000	6.88	0.05	0.60	0.60	1		•								
06IR 1.00 ISO IC228	4.00	1.000	6.88	0.05	0.60	0.60	1		•								
06IR 1.00 ISO IC908	4.00	1.000	6.88	0.05	0.60	0.60	1									•	
06IR 1.00 ISO IC928	4.00	1.000	6.88	0.05	0.60	0.60	1			•							
06IL 1.25 ISO IC228	4.00	1.250	6.88	0.07	0.60	0.60	1		•								
06IR 1.25 ISO IC228	4.00	1.250	6.88	0.07	0.60	0.60	1		•								
06IR 1.25 ISO IC908	4.00	1.250	6.88	0.07	0.60	0.60	1									•	
06IR 1.25 ISO IC928	4.00	1.250	6.88	0.07	0.60	0.60	1			•							
08IL 0.50 ISO IC228	5.00	0.500	8.24	0.04	0.40	0.60	1		•								
08IR 0.50 ISO IC228	5.00	0.500	8.24	0.04	0.40	0.60	1		•								
08IR 0.50 ISO IC908	5.00	0.500	8.24	0.04	0.40	0.60	1									•	
08IR 0.50 ISO IC928	5.00	0.500	8.24	0.04	0.40	0.60	1			•							
08IR 0.75 ISO IC228	5.00	0.750	8.24	0.06	0.45	0.60	1		•								
08IR 0.75 ISO IC908	5.00	0.750	8.24	0.06	0.50	0.60	1									•	
08IR 0.75 ISO IC928	5.00	0.750	8.24	0.06	0.50	0.60	1			•							
08IL 1.00 ISO IC228	5.00	1.000	8.24	0.07	0.60	0.60	1		•								
08IR 1.00 ISO IC228	5.00	1.000	8.24	0.07	0.60	0.60	1		•								
08IR 1.00 ISO IC908	5.00	1.000	8.24	0.07	0.60	0.60	1									•	
08IR 1.00 ISO IC928	5.00	1.000	8.24	0.07	0.60	0.60	1			•							
08IL 1.25 ISO IC228	5.00	1.250	8.24	0.09	0.70	0.60	1		•								
08IR 1.25 ISO IC228	5.00	1.250	8.66	0.09	0.70	0.60	1		•								
08IR 1.25 ISO IC908	5.00	1.250	8.24	0.09	0.70	0.60	1									•	
08IR 1.25 ISO IC928	5.00	1.250	8.24	0.09	0.70	0.60	1			•							
08IL 1.50 ISO IC228	5.00	1.500	8.24	0.12	0.70	0.60	1		•								
08IR 1.50 ISO IC228	5.00	1.500	8.24	0.12	0.70	0.60	1		•								
08IR 1.50 ISO IC28	5.00	1.500	8.24	0.12	0.70	0.60	1	•									
08IR 1.50 ISO IC908	5.00	1.500	8.24	0.12	0.70	0.60	1									•	
08IR 1.50 ISO IC928	5.00	1.500	8.24	0.12	0.70	0.60	1			•							
08IL 1.75 ISO IC228	5.00	1.750	8.24	0.15	0.90	0.60	1		•								
08IR 1.75 ISO IC228	5.00	1.750	8.66	0.15	0.90	0.60	1		•								
08IR 1.75 ISO IC908	5.00	1.750	8.24	0.15	0.90	0.60	1									•	
08IR 1.75 ISO IC928	5.00	1.750	8.24	0.15	0.85	0.60	1			•							
08UIRL 2.00 ISO IC228	5.00	2.000	8.66	0.14	4.33	0.80	1		•								
11IL 0.35 ISO IC08	6.35	0.350	11.00	0.03	0.30	0.60	1						•				
11IR 0.35 ISO IC908	6.35	0.350	11.00	0.03	0.30	0.60	1									•	
11IR 0.40 ISO IC908	6.35	0.400	11.00	0.03	0.40	0.80	1									•	
11IL 0.50 ISO IC908	6.35	0.500	11.00	0.04	0.60	0.80	1									•	
11IR 0.50 ISO IC08	6.35	0.500	11.00	0.04	0.60	0.80	1						•				
11IR 0.50 ISO IC250	6.35	0.500	11.00	0.04	0.60	0.80	1				•						
11IR 0.50 ISO IC908	6.35	0.500	11.00	0.04	0.60	0.80	1									•	
11IRB 0.50 ISO IC908	6.35	0.500	11.00	0.04	0.60	0.80	1									•	
11IRM 0.50 ISO IC908	6.35	0.500	11.00	0.04	0.40	0.30	1									•	
11IR 0.70 ISO IC908	6.35	0.700	11.00	0.05	0.60	0.60	1									•	
11IL 0.75 ISO IC908	6.35	0.750	11.00	0.05	0.60	0.60	1									•	
11IR 0.75 ISO IC908	6.35	0.750	11.00	0.05	0.60	0.60	1									•	
11IRB 0.75 ISO IC908	6.35	0.750	11.00	0.05	0.60	0.10	1									•	

• For Insert Identification System, see page 714 • Tolerance: Class 6H. • For technical information and detailed cutting data, see pages 809-825

(1) With pressed chipformer

(2) Multi-tooth

(3) Thread pitch

(4) Number of teeth per corner

For tools, see pages: AVC-D-SIR/L (805) • C#-SIR/L (803) • MGSIR/L (156) • PICIN-A-SIR/L (466) • PICIN-MGSIR/L (466) • SIR/L (801)

Continued

ISCAR THREAD

IR/L-ISO

Internal ISO Metric (DIN13 12-1986 class 6H) Laydown Threading Inserts for General Applications

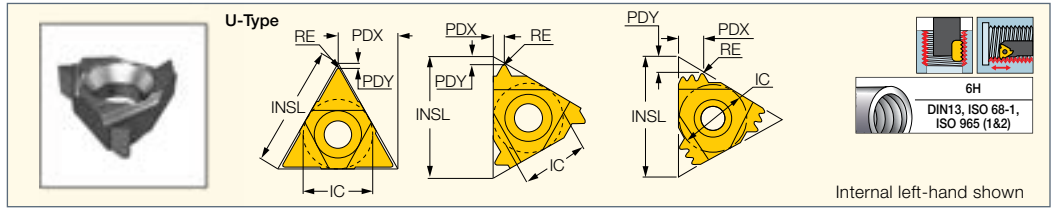

Internal left-hand shown

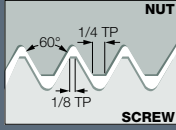

Designation	Dimensions							Tough ↔ Hard										
	IC	TP ⁽³⁾	INSL	RE	PDX	PDY	CICT ⁽⁴⁾	IC28	IC228	IC928	IC50M	IC250	IC08	IC508	IC808	IC908	IC1007	
11IRM 0.75 ISO IC908	6.35	0.750	11.00	0.06	0.50	0.30	1										•	
11IR 0.80 ISO IC908	6.35	0.800	11.00	0.04	0.60	0.60	1										•	
11IRB 0.80 ISO IC908	6.35	0.800	11.00	0.04	0.60	0.60	1										•	
11IL 1.00 ISO IC908	6.35	1.000	11.00	0.07	0.65	0.60	1										•	
11IR 1.00 ISO IC08	6.35	1.000	11.00	0.07	0.65	0.60	1						•					
11IR 1.00 ISO IC1007	6.35	1.000	11.00	0.07	0.65	0.77	1											•
11IR 1.00 ISO IC228	6.35	1.000	11.00	0.07	0.65	0.60	1	•										
11IR 1.00 ISO IC250	6.35	1.000	11.00	0.07	0.65	0.60	1					•						
11IR 1.00 ISO IC50M	6.35	1.000	11.00	0.07	0.65	0.60	1					•						
11IR 1.00 ISO IC908	6.35	1.000	11.00	0.07	0.65	0.77	1										•	
11IRB 1.00 ISO IC908	6.35	1.000	11.00	0.07	0.60	0.60	1										•	
11IRM 1.00 ISO IC1007	6.35	1.000	11.00	0.05	0.70	0.60	1											•
11IRM 1.00 ISO IC808 ⁽¹⁾	6.35	1.000	11.00	0.05	0.70	0.60	1								•			
11IRM 1.00 ISO IC908 ⁽¹⁾	6.35	1.000	11.00	0.05	0.70	0.60	1										•	
11IL 1.25 ISO IC908	6.35	1.250	11.00	0.09	0.80	0.80	1										•	
11IR 1.25 ISO IC908	6.35	1.250	11.00	0.09	0.80	0.80	1										•	
11IRB 1.25 ISO IC908	6.35	1.250	11.00	0.09	0.90	0.80	1										•	
11IL 1.50 ISO IC250	6.35	1.500	11.00	0.12	1.00	0.80	1					•						
11IL 1.50 ISO IC908	6.35	1.500	11.00	0.12	0.95	0.80	1										•	
11IR 1.50 ISO IC08	6.35	1.500	11.00	0.12	0.95	0.80	1						•					
11IR 1.50 ISO IC1007	6.35	1.500	11.00	0.12	0.95	0.80	1											•
11IR 1.50 ISO IC228	6.35	1.500	11.00	0.12	0.95	0.80	1	•										
11IR 1.50 ISO IC250	6.35	1.500	11.00	0.12	0.95	0.80	1					•						
11IR 1.50 ISO IC50M	6.35	1.500	11.00	0.12	0.95	0.80	1					•						
11IR 1.50 ISO IC908	6.35	1.500	11.00	0.12	0.95	0.80	1										•	
11IRB 1.50 ISO IC908	6.35	1.500	11.00	0.12	0.95	0.80	1										•	
11IRM 1.50 ISO IC1007 ⁽¹⁾	6.35	1.500	11.00	0.08	1.00	0.80	1											•
11IRM 1.50 ISO IC250 ⁽¹⁾	6.35	1.500	11.00	0.08	1.00	0.80	1					•						
11IRM 1.50 ISO IC908 ⁽¹⁾	6.35	1.500	11.00	0.08	1.00	0.80	1										•	
11IL 1.75 ISO IC50M	6.35	1.750	11.00	0.12	1.00	0.80	1					•						
11IL 1.75 ISO IC908	6.35	1.750	11.00	0.12	1.00	0.80	1										•	
11IR 1.75 ISO IC908	6.35	1.750	11.00	0.12	1.00	0.80	1										•	
11IRB 1.75 ISO IC908	6.35	1.750	11.00	0.12	1.00	0.80	1										•	
11IRM 1.75 ISO IC908	6.35	1.750	11.00	0.15	0.90	0.60	1										•	
11IL 2.00 ISO IC908	6.35	2.000	11.00	0.15	0.90	0.80	1										•	
11IR 2.00 ISO IC1007	6.35	2.000	11.00	0.15	1.00	0.80	1											•
11IR 2.00 ISO IC228	6.35	2.000	11.00	0.15	1.00	0.80	1	•										
11IR 2.00 ISO IC250	6.35	2.000	11.00	0.15	1.00	0.80	1					•						
11IR 2.00 ISO IC508	6.35	2.000	11.00	0.15	1.00	0.80	1						•					
11IR 2.00 ISO IC908	6.35	2.000	11.00	0.15	1.00	0.80	1										•	
11IRM 2.00 ISO IC908	6.35	2.000	11.00	0.16	1.00	0.60	1										•	
11IR 2.5 ISO IC908	6.35	2.500	11.00	0.18	1.20	0.80	1										•	
16IR 0.35 ISO IC908	9.52	0.350	16.49	0.02	0.30	0.60	1										•	
16IL 0.40 ISO IC908	9.52	0.400	16.49	0.03	0.40	0.60	1										•	
16IR 0.40 ISO IC908	9.52	0.400	16.49	0.03	0.40	0.60	1										•	
16IL 0.45 ISO IC908	9.52	0.450	16.49	0.02	0.40	0.80	1										•	
16IL 0.50 ISO IC908	9.52	0.500	16.49	0.04	0.60	0.60	1										•	
16IR 0.50 ISO IC08	9.52	0.500	16.49	0.04	0.60	0.60	1						•					
16IR 0.50 ISO IC250	9.52	0.500	16.49	0.04	0.60	0.60	1					•						
16IR 0.50 ISO IC908	9.52	0.500	16.49	0.04	0.60	0.60	1										•	
16IR 0.60 ISO IC908	9.52	0.600	16.49	0.04	0.60	0.60	1										•	
16IR 0.70 ISO IC250	9.52	0.700	16.49	0.05	0.60	0.60	1					•						
16IR 0.70 ISO IC908	9.52	0.700	16.49	0.05	0.60	0.60	1										•	
16IL 0.75 ISO IC908	9.52	0.750	16.49	0.06	0.60	1.00	1										•	

• For Insert Identification System, see page 714 • Tolerance: Class 6H. • For technical information and detailed cutting data, see pages 809-825

(1) With pressed chipformer

(2) Multi-tooth

(3) Thread pitch

(4) Number of teeth per corner

For tools, see pages: AVC-D-SIR/L (805) • C#-SIR/L (803) • MGSIR/L (156) • PICIN-A-SIR/L (466) • PICIN-MGSIR/L (466) • SIR/L (801)

Continued

ISCAR THREAD

IR/L-ISO

Internal ISO Metric (DIN13 12-1986 class 6H) Laydown Threading Inserts for General Applications

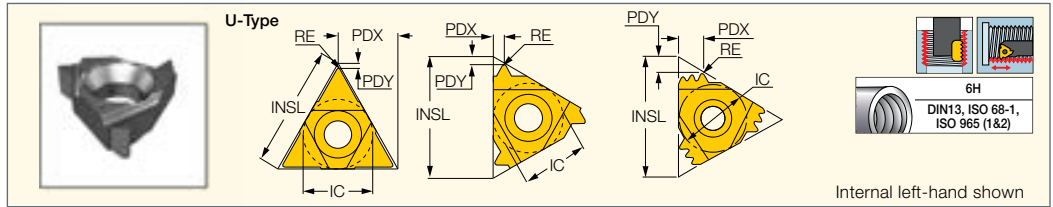

Designation	Dimensions							Tough ↔ Hard										
	IC	TP ⁽³⁾	INSL	RE	PDX	PDY	CICT ⁽⁴⁾	IC28	IC228	IC928	IC50M	IC250	IC08	IC508	IC808	IC908	IC1007	
16IR 0.75 ISO IC08	9.52	0.750	16.49	0.06	0.60	1.00	1											
16IR 0.75 ISO IC908	9.52	0.750	16.49	0.06	0.60	1.00	1											
16IL 0.80 ISO IC50M	9.52	0.800	16.49	0.05	0.60	0.60	1											
16IR 0.80 ISO IC250	9.52	0.800	16.49	0.05	0.60	0.60	1											
16IL 1.00 ISO IC908	9.52	1.000	16.49	0.07	0.80	0.70	1											
16IR 1.00 ISO IC08	9.52	1.000	16.49	0.07	0.80	0.70	1											
16IR 1.00 ISO IC1007	9.52	1.000	16.49	0.07	0.80	0.70	1											
16IR 1.00 ISO IC250	9.52	1.000	16.49	0.07	0.80	0.70	1											
16IR 1.00 ISO IC50M	9.52	1.000	16.49	0.07	0.80	0.70	1											
16IR 1.00 ISO IC908	9.52	1.000	16.49	0.07	0.80	0.70	1											
16IR 1.00 ISO 3M IC908 ⁽²⁾	9.52	1.000	16.49	0.07	2.50	1.50	3											
16IRB 1.00 ISO IC908 ⁽¹⁾	9.52	1.000	16.49	0.07	0.80	0.70	1											
16IRM 1.00 ISO IC1007 ⁽¹⁾	9.52	1.000	16.49	0.05	0.70	0.60	1											
16IRM 1.00 ISO IC250 ⁽¹⁾	9.52	1.000	16.49	0.05	0.70	0.60	1											
16IRM 1.00 ISO IC50M ⁽¹⁾	9.52	1.000	16.49	0.05	0.70	0.60	1											
16IRM 1.00 ISO IC508 ⁽¹⁾	9.52	1.000	16.49	0.05	0.70	0.60	1											
16IRM 1.00 ISO IC808 ⁽¹⁾	9.52	1.000	16.49	0.05	0.70	0.60	1											
16IRM 1.00 ISO IC908 ⁽¹⁾	9.52	1.000	16.49	0.05	0.70	0.60	1											
16IL 1.25 ISO IC08	9.52	1.250	16.49	0.09	0.90	0.80	1											
16IL 1.25 ISO IC50M	9.52	1.250	16.49	0.09	0.90	0.80	1											
16IL 1.25 ISO IC908	9.52	1.250	16.49	0.09	0.90	0.80	1											
16IR 1.25 ISO IC08	9.52	1.250	16.49	0.09	0.90	0.80	1											
16IR 1.25 ISO IC250	9.52	1.250	16.49	0.09	0.90	0.80	1											
16IR 1.25 ISO IC908	9.52	1.250	16.49	0.09	0.90	0.80	1											
16IRB 1.25 ISO IC908 ⁽¹⁾	9.52	1.250	16.49	0.09	0.80	0.70	1											
16IRM 1.25 ISO IC1007 ⁽¹⁾	9.52	1.250	16.49	0.06	0.90	0.80	1											
16IRM 1.25 ISO IC250 ⁽¹⁾	9.52	1.250	16.49	0.06	0.90	0.80	1											
16IRM 1.25 ISO IC908 ⁽¹⁾	9.52	1.250	16.49	0.06	0.90	0.80	1											
16IL 1.50 ISO IC1007	9.52	1.500	16.49	0.12	1.15	0.90	1											
16IL 1.50 ISO IC250	9.52	1.500	16.49	0.12	1.20	0.90	1											
16IL 1.50 ISO IC50M	9.52	1.500	16.49	0.12	1.15	0.90	1											
16IL 1.50 ISO IC908	9.52	1.500	16.49	0.12	1.15	0.90	1											
16IR 1.50 ISO IC08	9.52	1.500	16.49	0.12	1.00	0.90	1											
16IR 1.50 ISO IC1007	9.52	1.500	16.49	0.12	1.00	0.90	1											
16IR 1.50 ISO IC228	9.52	1.500	16.49	0.12	1.15	0.90	1											
16IR 1.50 ISO IC250	9.52	1.500	16.49	0.12	1.00	0.90	1											
16IR 1.50 ISO IC50M	9.52	1.500	16.49	0.12	1.15	0.90	1											
16IR 1.50 ISO IC908	9.52	1.500	16.49	0.12	1.00	0.90	1											
16IR 1.50 ISO 2M IC908 ⁽²⁾	9.52	1.500	16.49	0.10	2.30	1.50	2											
16IRB 1.50 ISO IC908 ⁽¹⁾	9.52	1.500	16.49	0.12	1.15	0.90	1											
16IRM 1.50 ISO IC1007 ⁽¹⁾	9.52	1.500	16.49	0.08	1.00	0.80	1											
16IRM 1.50 ISO IC250 ⁽¹⁾	9.52	1.500	16.49	0.08	1.00	0.80	1											
16IRM 1.50 ISO IC50M ⁽¹⁾	9.52	1.500	16.49	0.08	1.00	0.80	1											
16IRM 1.50 ISO IC508 ⁽¹⁾	9.52	1.500	16.49	0.08	1.00	0.80	1											
16IRM 1.50 ISO IC808 ⁽¹⁾	9.52	1.500	16.49	0.08	1.00	0.80	1											
16IRM 1.50 ISO IC908 ⁽¹⁾	9.52	1.500	16.49	0.08	1.00	0.80	1											
16IL 1.75 ISO IC908	9.52	1.750	16.49	0.12	1.20	0.90	1											
16IR 1.75 ISO IC08	9.52	1.750	16.49	0.12	1.20	0.90	1											
16IR 1.75 ISO IC250	9.52	1.750	16.49	0.12	1.20	0.90	1											
16IR 1.75 ISO IC908	9.52	1.750	16.49	0.12	1.20	0.90	1											
16IRB 1.75 ISO IC908 ⁽¹⁾	9.52	1.750	16.49	0.12	1.20	0.90	1											
16IRM 1.75 ISO IC1007	9.52	1.750	16.49	0.10	1.20	0.90	1											
16IRM 1.75 ISO IC250 ⁽¹⁾	9.52	1.750	16.49	0.10	1.20	0.90	1											

• For Insert Identification System, see page 714 • Tolerance: Class 6H. • For technical information and detailed cutting data, see pages 809-825

⁽¹⁾ With pressed chipformer

⁽²⁾ Multi-tooth

⁽³⁾ Thread pitch

⁽⁴⁾ Number of teeth per corner

For tools, see pages: AVC-D-SIR/L (805) • C#-SIR/L (803) • MGSIR/L (156) • PICIN-A-SIR/L (466) • PICIN-MGSIR/L (466) • SIR/L (801)

Continued

ISCAR THREAD

IR/L-ISO

Internal ISO Metric (DIN13 12-1986 class 6H) Laydown Threading Inserts for General Applications

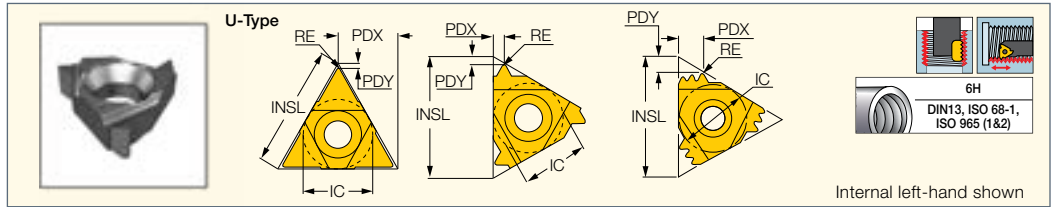

Designation	Dimensions							Tough ↔ Hard										
	IC	TP ⁽³⁾	INSL	RE	PDX	PDY	CICT ⁽⁴⁾	IC28	IC228	IC928	IC50M	IC250	IC08	IC508	IC808	IC908	IC1007	
16IRM 1.75 ISO IC808 ⁽¹⁾	9.52	1.750	16.49	0.10	1.20	0.90	1											
16IRM 1.75 ISO IC908 ⁽¹⁾	9.52	1.750	16.49	0.10	1.20	0.90	1											
16IL 2.00 ISO IC250	9.52	2.000	16.49	0.16	1.20	0.90	1					•						
16IL 2.00 ISO IC908	9.52	2.000	16.49	0.16	1.20	0.90	1											
16IR 2.00 ISO IC1007	9.52	2.000	16.49	0.16	1.20	0.90	1										•	
16IR 2.00 ISO IC228	9.52	2.000	16.49	0.16	1.20	0.90	1		•									
16IR 2.00 ISO IC250	9.52	2.000	16.49	0.16	1.20	0.90	1					•						
16IR 2.00 ISO IC508	9.52	2.000	16.49	0.16	1.20	0.90	1							•				
16IR 2.00 ISO IC908	9.52	2.000	16.49	0.16	1.20	0.90	1									•		
16IR 2.00 ISO 2M IC908 ⁽²⁾	9.52	2.000	16.49	0.14	2.70	1.60	2									•		
16IRB 2.00 ISO IC908 ⁽¹⁾	9.52	2.000	16.49	0.14	1.15	1.00	1									•		
16IRM 2.00 ISO IC1007 ⁽¹⁾	9.52	2.000	16.49	0.11	1.30	1.00	1										•	
16IRM 2.00 ISO IC250 ⁽¹⁾	9.52	2.000	16.49	0.11	1.30	1.00	1					•						
16IRM 2.00 ISO IC508 ⁽¹⁾	9.52	2.000	16.49	0.11	1.30	1.00	1							•				
16IRM 2.00 ISO IC808 ⁽¹⁾	9.52	2.000	16.49	0.11	1.30	1.00	1								•			
16IRM 2.00 ISO IC908 ⁽¹⁾	9.52	2.000	16.49	0.11	1.30	1.00	1									•		
16IL 2.50 ISO IC908	9.52	2.500	16.49	0.19	1.40	1.15	1									•		
16IR 2.50 ISO IC1007	9.52	2.500	16.49	0.19	1.40	1.20	1										•	
16IR 2.50 ISO IC228	9.52	2.500	16.49	0.19	1.40	1.15	1		•									
16IR 2.50 ISO IC250	9.52	2.500	16.49	0.19	1.40	1.15	1					•						
16IR 2.50 ISO IC908	9.52	2.500	16.49	0.19	1.40	1.15	1									•		
16IRB 2.50 ISO IC908	9.52	2.500	16.49	0.19	1.50	1.20	1									•		
16IRM 2.50 ISO IC1007 ⁽¹⁾	9.52	2.500	16.49	0.14	1.50	1.10	1										•	
16IRM 2.50 ISO IC250 ⁽¹⁾	9.52	2.500	16.49	0.14	1.50	1.10	1					•						
16IRM 2.50 ISO IC808 ⁽¹⁾	9.52	2.500	16.49	0.14	1.50	1.10	1								•			
16IRM 2.50 ISO IC908 ⁽¹⁾	9.52	2.500	16.49	0.14	1.50	1.10	1									•		
16IL 3.00 ISO IC908	9.52	3.000	16.49	0.21	1.50	1.10	1									•		
16IR 3.00 ISO IC1007	9.52	3.000	16.49	0.21	1.50	1.10	1										•	
16IR 3.00 ISO IC228	9.52	3.000	16.49	0.21	1.50	1.10	1		•									
16IR 3.00 ISO IC250	9.52	3.000	16.49	0.21	1.50	1.10	1					•						
16IR 3.00 ISO IC908	9.52	3.000	16.49	0.21	1.50	1.10	1									•		
16IRB 3.00 ISO IC908 ⁽¹⁾	9.52	3.000	16.49	0.21	1.50	1.10	1									•		
16IRM 3.00 ISO IC1007 ⁽¹⁾	9.52	3.000	16.49	0.22	1.50	1.10	1										•	
16IRM 3.00 ISO IC250 ⁽¹⁾	9.52	3.000	16.49	0.22	1.50	1.10	1					•						
16IRM 3.00 ISO IC508 ⁽¹⁾	9.52	3.000	16.49	0.22	1.50	1.10	1							•				
16IRM 3.00 ISO IC808 ⁽¹⁾	9.52	3.000	16.49	0.22	1.50	1.10	1								•			
16IRM 3.00 ISO IC908 ⁽¹⁾	9.52	3.000	16.49	0.22	1.50	1.10	1									•		
16IR 3.50 ISO IC1007	9.52	3.500	16.49	0.26	1.60	1.50	1										•	
22IR 1.50 ISO 3M IC250 ⁽²⁾	12.70	1.500	22.00	0.11	3.70	2.30	3					•						
22IR 1.50 ISO 3M IC908 ⁽²⁾	12.70	1.500	22.00	0.11	3.70	2.30	3									•		
22IR 2.00 ISO 2M IC908 ⁽²⁾	12.70	2.000	22.00	0.15	3.00	2.30	2									•		
22IR 2.00 ISO 3M IC908 ⁽²⁾	12.70	2.000	22.00	0.13	5.00	3.10	3									•		
22IL 3.00 ISO IC228	12.70	3.000	22.00	0.17	1.50	1.10	1		•									
22IL 3.50 ISO IC250	12.70	3.500	22.00	0.23	2.30	1.60	1					•						
22IR 3.50 ISO IC1007	12.70	3.500	22.00	0.23	2.30	1.60	1										•	
22IR 3.50 ISO IC250	12.70	3.500	22.00	0.23	2.30	1.60	1					•						
22IR 3.50 ISO IC908	12.70	3.500	22.00	0.23	2.30	1.60	1									•		
22IL 4.00 ISO IC908	12.70	4.000	22.00	0.27	2.30	1.60	1									•		
22IR 4.00 ISO IC250	12.70	4.000	22.00	0.27	2.30	1.60	1					•						
22IR 4.00 ISO IC50M	12.70	4.000	22.00	0.27	2.30	1.60	1				•							
22IR 4.00 ISO IC908	12.70	4.000	22.00	0.27	2.30	1.60	1									•		
22IL 4.50 ISO IC250	12.70	4.500	22.00	0.31	2.30	1.60	1					•						
22IR 4.50 ISO IC250	12.70	4.500	22.00	0.31	2.30	1.60	1					•						

• For Insert Identification System, see page 714 • Tolerance: Class 6H. • For technical information and detailed cutting data, see pages 809-825

⁽¹⁾ With pressed chipformer

⁽²⁾ Multi-tooth

⁽³⁾ Thread pitch

⁽⁴⁾ Number of teeth per corner

For tools, see pages: AVC-D-SIR/L (805) • C#-SIR/L (803) • MGSIR/L (156) • PICIN-A-SIR/L (466) • PICIN-MGSIR/L (466) • SIR/L (801)

IR/L-ISO

Internal ISO Metric (DIN13 12-1986 class 6H) Laydown Threading Inserts for General Applications

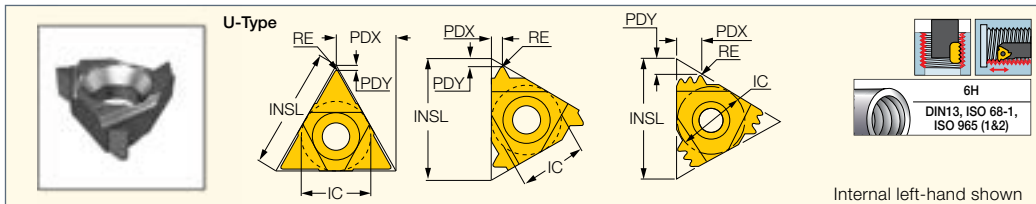

Designation	Dimensions							Tough ↔ Hard									
	IC	TP ⁽³⁾	INSL	RE	PDX	PDY	CICT ⁽⁴⁾	IC28	IC228	IC928	IC50M	IC250	IC08	IC508	IC808	IC908	IC1007
22IR 4.50 ISO IC908	12.70	4.500	22.00	0.31	2.30	1.60	1									•	
22IL 5.00 ISO IC50M	12.70	5.000	22.00	0.32	2.50	1.70	1				•						
22IL 5.00 ISO IC908	12.70	5.000	22.00	0.32	2.50	1.70	1									•	
22IR 5.00 ISO IC250	12.70	5.000	22.00	0.32	2.50	1.70	1					•					
22IR 5.00 ISO IC908	12.70	5.000	22.00	0.32	2.50	1.70	1									•	
22UIRL 5.50 ISO IC250	12.70	5.500	22.00	0.36	11.00	2.30	1					•					
22IR 6.00 ISO IC908	12.70	6.000	22.00	0.40	2.50	1.70	1									•	
22UIRL 6.00 ISO IC250	12.70	6.000	22.00	0.40	11.00	2.10	1					•					
27IR 3.00 ISO 2M IC908 ⁽²⁾	15.88	3.000	27.50	0.21	4.60	3.10	2									•	
27IR 5.50 ISO IC250	15.88	5.500	27.50	0.36	2.50	1.80	1					•					
27IR 5.50 ISO IC908	15.88	5.500	27.50	0.36	2.50	1.80	1									•	
27IR 6.00 ISO IC250	15.88	6.000	27.50	0.45	2.40	1.85	1					•					
27IR 6.00 ISO IC908	15.88	6.000	27.50	0.45	2.40	1.85	1									•	
27UIRL 8.00 ISO IC908	15.88	8.000	27.50	0.50	13.80	2.50	1									•	

• For Insert Identification System, see page 714 • Tolerance: Class 6H. • For technical information and detailed cutting data, see pages 809-825

- (1) With pressed chipformer
- (2) Multi-tooth
- (3) Thread pitch
- (4) Number of teeth per corner

For tools, see pages: AVC-D-SIR/L (805) • C#-SIR/L (803) • MGSIR/L (156) • PICIN-A-SIR/L (466) • PICIN-MGSIR/L (466) • SIR/L (801)

PENTACUT
THREADING LINE

PENTA 24-ISO
Precision Ground ISO Metric
Full Profile Pentagonal
External Threading Inserts
with a Chipformer

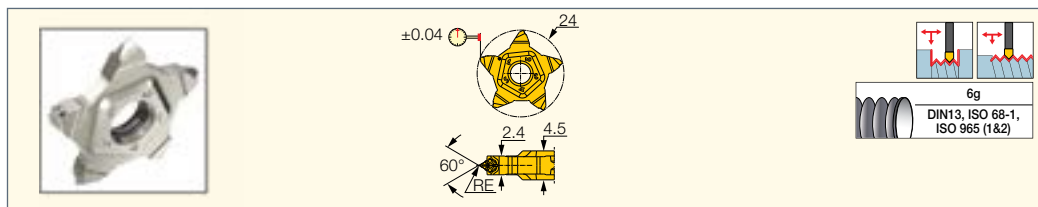

Designation	Dimensions			
	TP ⁽¹⁾	RE	IC908	
PENTA 24-0.5-ISO IC908	0.500	0.08	●	
PENTA 24-0.75-ISO IC908	0.750	0.11	●	
PENTA 24-0.8-ISO IC908	0.800	0.12	●	
PENTA 24-1.0-ISO IC908	1.000	0.14	●	
PENTA 24-1.25-ISO IC908	1.250	0.18	●	
PENTA 24-1.5-ISO IC908	1.500	0.22	●	
PENTA 24-1.75-ISO IC908	1.750	0.25	●	
PENTA 24-2.0-ISO IC908	2.000	0.28	●	

• DMIN(mm)=5.435xTP

⁽¹⁾ Thread pitch

For tools, see pages: NQCH-PCHR/L-24-JHP (348) • PCAD RE/LE-JHP (561) • PCADR/L (353) • PCADR/L-JHP (353) • PCHBR/L (355)

• PCHR/L-24 (346) • PCHR/L-24-JHP (347) • PCHR/L-24-JHP-MC (348)

SWISSCUT
INNOVAL LINE
ISCARTHREAD

SCIR-22-MTR-ISO
Precision Ground ISO Metric
Full Profile Threading Inserts

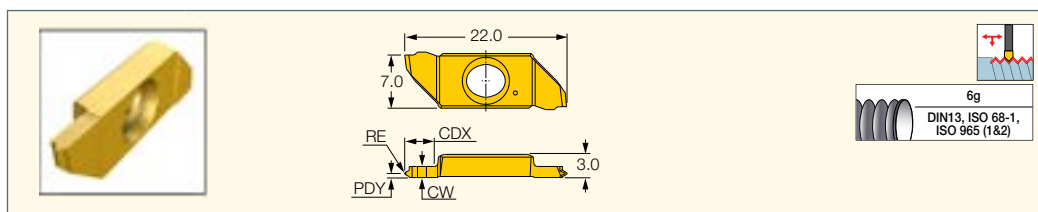

Designation	Dimensions					IC1008
	TP ⁽¹⁾	CW	CDX ⁽²⁾	RE	PDY	
SCIR 22-MTR-0.3ISO IC1008	0.300	1.00	3.00	0.03	0.2	●
SCIR 22-MTR-0.4ISO IC1008	0.400	1.00	3.00	0.04	0.2	●
SCIR 22-MTR-0.5ISO IC1008	0.500	1.00	3.00	0.06	0.3	●
SCIR 22-MTR-0.75ISO IC1008	0.750	1.00	3.00	0.10	0.4	●
SCIR 22-MTR-1.0ISO IC1008	1.000	1.50	4.00	0.14	0.6	●
SCIR 22-MTR-1.5ISO IC1008	1.500	2.00	4.00	0.20	0.8	●

⁽¹⁾ Thread pitch

⁽²⁾ Cutting depth maximum

For tools, see pages: NQCH-SCHR/L-BF-JHP (408) • NQCH-Y-SCHR-BF-JHP (408) • SCHR/L-22BF (407) • SCHR/L-22BF-JHP (407) • Y-SCHR-22BF (407)

• Y-SCHR-22BF-JHP (408)

CUTGRIP
ISCARTHREAD

TIP-P-ISO

Precision Ground ISO
Metric Full Profile Double-
Ended External Threading
Inserts with a Chipformer

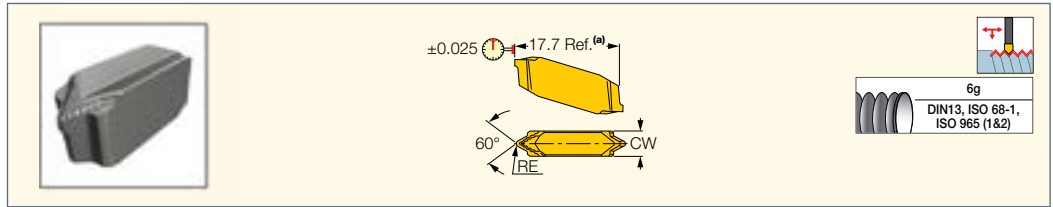

Designation	Dimensions				Tough ← Hard	
	TP ⁽¹⁾	CW	RE	RETOL ⁽²⁾	IC08	IC908
TIP 2P0.5-ISO IC08	0.500	2.40	0.08	0.030	●	
TIP 2P0.5-ISO IC908	0.500	2.40	0.08	0.030		●
TIP 2P0.75-ISO IC08	0.750	2.40	0.11	0.030	●	
TIP 2P0.75-ISO IC908	0.750	2.40	0.11	0.030		●
TIP 2P0.8-ISO IC08	0.800	2.40	0.12	0.030	●	
TIP 2P0.8-ISO IC908	0.800	2.40	0.12	0.030		●
TIP 2P1.0-ISO IC08	1.000	2.40	0.14	0.030	●	
TIP 2P1.0-ISO IC908	1.000	2.40	0.14	0.030		●
TIP 2P1.25-ISO IC08	1.250	2.40	0.18	0.030	●	
TIP 2P1.25-ISO IC908	1.250	2.40	0.18	0.030		●
TIP 2P1.5-ISO IC08	1.500	2.40	0.22	0.030	●	
TIP 2P1.5-ISO IC908	1.500	2.40	0.22	0.030		●
TIP 2P1.75-ISO IC08	1.750	2.40	0.25	0.030	●	
TIP 2P1.75-ISO IC908	1.750	2.40	0.25	0.030		●
TIP 4P2.0-ISO IC08	2.000	4.00	0.28	0.030	●	
TIP 4P2.0-ISO IC908	2.000	4.00	0.28	0.030		●
TIP 4P2.5-ISO IC08	2.500	4.00	0.35	0.050	●	
TIP 4P2.5-ISO IC908	2.500	4.00	0.35	0.050		●
TIP 4P3.0-ISO IC908	3.000	4.00	0.42	0.050		●
TIP 4P3.5-ISO IC908	3.500	4.00	0.48	0.050		●
TIP 5P4.0-ISO IC908	4.000	5.50	0.55	0.050		●
TIP 5P5.0-ISO IC908	5.000	5.50	0.68	0.050		●

- (a) TIP inserts are 1.6 mm longer than GIP in the same pocket
- Toolholder seat needs to be modified according to insert profile to ensure clearance
- (1) Thread pitch
- (2) Corner radius tolerance (+/-)

For tools, see pages: C#-GHDR/L (301) • CGHN-D (310) • CGHN-DG (310) • CGHN-S (309) • CGPAD (308) • CGPAD-JHP (309) • GHDR/L (short pocket) (302) • GHDR/L-JHP (short pocket) (303) • GHDR/L-JHP-MC (short pocket) (304) • GHGR/L (305) • GHMPR/L (300) • GHMR/L (300) • GHSL/L (428) • GHSL/L-JHP-SL (429) • NQCH-GHSL/L-JHP (428)

PICCO CUT

PICCO ISO Full Profile
ISO Standard Inserts for
Full Profile Threads

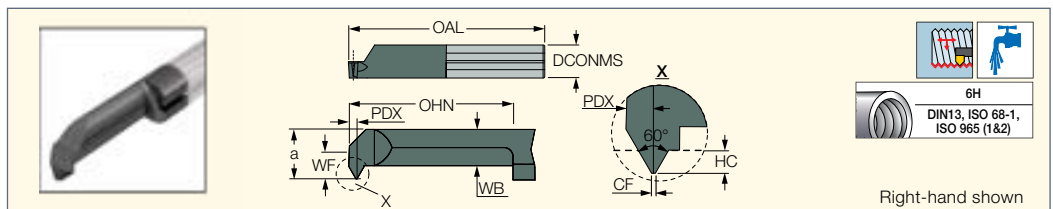

Designation	Dimensions										IC908	
	DCONMS	DMIN	HC	CF	PDX	WF	a	WB	OHN ⁽¹⁾	OAL		TP ⁽²⁾
PICCO R/L 105.0510-15	5.00	4.80	0.54	0.12	0.60	1.90	4.40	3.30	15.0	30.00	1.000	●
PICCO R/L 106.0612-15	6.00	6.00	0.67	0.15	0.70	2.30	5.30	3.40	15.0	30.00	1.250	●
PICCO R/L 106.0815-15	6.00	6.00	0.81	0.18	0.80	2.30	5.30	3.40	15.0	30.00	1.500	●
PICCO R/L 107.0815-15	7.00	7.00	0.81	0.18	0.80	2.80	6.30	3.80	15.0	30.00	1.500	●

- (1) Minimum overhang
 - (2) Thread pitch
- For holders, see pages:** PICCO ACE (440) • PICCO/MG PCO (Holder) (441) • SC-PICCO (420)

PICCO^{CUT}

PICCO ISO Full Profile Fine
ISO Fine Pitch Inserts for
Full Profile Threads

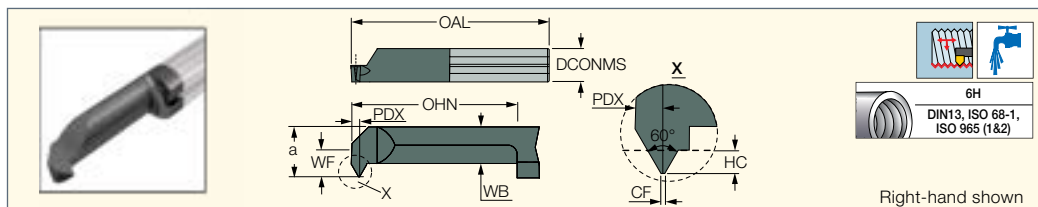

Right-hand shown

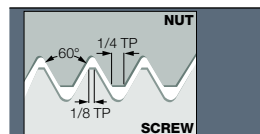

Dimensions

Designation	DCONMS	DMIN	HC	CF	PDX	WF	a	OHN ⁽¹⁾	WB	OAL	TP ⁽²⁾	IC908
PICCO R/L 104.0205-15	5.00	4.00	0.27	0.06	0.40	1.50	3.50	15.0	2.40	30.00	0.500	●
PICCO R/L 105.0205-15	5.00	5.00	0.27	0.06	0.40	1.90	4.40	15.0	3.30	30.00	0.500	●
PICCO R/L 105.0407-15	5.00	5.00	0.40	0.09	0.50	1.90	4.40	15.0	3.30	30.00	0.750	●
PICCO R/L 106.0510-15	6.00	6.00	0.54	0.12	0.60	2.30	5.30	15.0	3.40	30.00	1.000	●

⁽¹⁾ Minimum overhang

⁽²⁾ Thread pitch

For holders, see pages: PICCO ACE (440) • PICCO/MG PCO (Holder) (441) • SC-PICCO (420)

PICCOINDEX

INDEXABLE INSERTS

PICIN-MGSIR/L

Solid Carbide PICCO Tools on which
Internal Laydown
Threading Inserts are Mounted

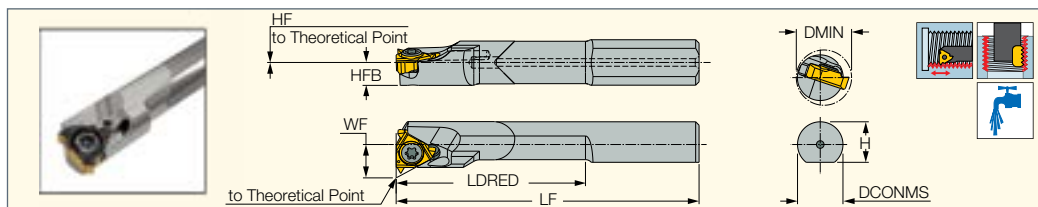

Designation	DCONMS	DMIN	LDRED	H	HFB	WF	HF	LF	MID ⁽¹⁾		
PICIN E06-T25-MGSIL-06	6.00	7.30	25.0	5.4	3.0	4.41	0.0	40.00	06IL A 55	SR 14-552	T-6/5
PICIN E06-T25-MGSIR-06	6.00	7.30	25.0	5.4	3.0	4.41	0.0	40.00	06IR A 55		

• B-steel shank with coolant hole, CB-carbide shank with coolant hole • All toolholders provide 1.5 helix angle, either via the pocket or the anvil supplied

• For GTGA inserts, use anvil AL 16-0

⁽¹⁾ Master insert identification

For inserts, see pages: IR/L-55° (716) • IR/L-60° (723) • IR/L-BSPT (767) • IR/L-ISO (737) • IR/L-NPT (762) • IR/L-NPTF (765) • IR/L-UN (749) • IR/L-W (757)

For holders, see pages: PICCO ACE (440) • PICCO/MG PCO (Holder) (441) • SC-PICCO (420)

PICCOINDEX

INDEXABLE INSERTS

PICIN-A-SIR/L

PICCO Tools on which
Internal Laydown Threading
Inserts are Mounted

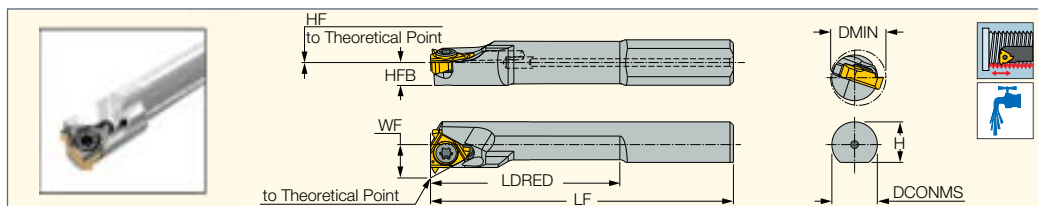

Designation	DCONMS	DMIN	LDRED	H	HFB	WF	LF	HF	MID ⁽¹⁾		
PICIN A06-T15-SIR-06	6.00	7.30	15.0	5.4	3.0	4.41	30.00	0.1	06IL A 55	SR 14-552	T-6/5
PICIN A06-T25-SIR/L-06	6.00	7.30	25.0	5.4	3.0	4.41	40.00	0.1	06IL/R A 55	SR 14-552	T-6/5

NEW

• B-steel shank with coolant hole, CB-carbide shank with coolant hole • All toolholders provide 1.5 helix angle, either via the pocket or the anvil supplied

• For GTGA inserts, use anvil AL 16-0

⁽¹⁾ Master insert identification

For inserts, see pages: IR/L-55° (716) • IR/L-60° (723) • IR/L-BSPT (767) • IR/L-ISO (737) • IR/L-NPT (762) • IR/L-NPTF (765) • IR/L-UN (749) • IR/L-W (757)

For holders, see pages: PICCO ACE (440) • PICCO/MG PCO (Holder) (441) • SC-PICCO (420)

ER/L-UN

External American UN Full Profile (UN, UNC, UNF, UNEF) Laydown Threading Inserts for General Applications

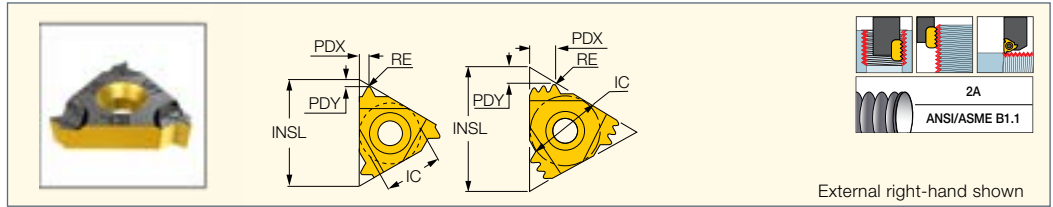

External right-hand shown

Designation	Dimensions							Tough ↔ Hard							
	IC	TPI ⁽³⁾	INSL	RE	PDX	PDY	CICT ⁽⁴⁾	IC228	IC50M	IC250	IC08	IC508	IC808	IC908	IC1007
11ER 56 UN IC908	6.35	56.0	11.00	0.07	0.40	0.60	1								•
11ER 48 UN IC250	6.35	48.0	11.00	0.08	0.45	0.60	1			•					
11ER 44 UN IC908	6.35	44.0	11.00	0.09	0.60	0.60	1								•
11EL 32 UN IC250	6.35	32.0	11.00	0.12	0.60	0.70	1			•					
11ER 32 UN IC908	6.35	32.0	11.00	0.12	0.60	0.60	1								•
11ER 28 UN IC08	6.35	28.0	11.00	0.10	0.70	0.60	1				•				
11ER 28 UN IC908	6.35	28.0	11.00	0.10	0.70	0.60	1								•
11ER 24 UN IC908	6.35	24.0	11.00	0.12	0.80	0.70	1								•
11ER/L 20 UN IC908	6.35	20.0	11.00	0.19	0.80	0.70	1								•
11ER 20 UN IC08	6.35	20.0	11.00	0.19	0.80	0.70	1				•				
11ER 20 UN IC250	6.35	20.0	11.00	0.19	0.80	0.70	1			•					
11ER 18 UN IC08	6.35	18.0	11.00	0.17	1.00	0.80	1				•				
11ER 18 UN IC908	6.35	18.0	11.00	0.17	1.00	0.80	1								•
11ER 16 UN IC250	6.35	16.0	11.00	0.18	1.10	0.90	1			•					
11ER 16 UN IC50M	6.35	16.0	11.00	0.18	1.10	0.90	1		•						
11ER 16 UN IC908	6.35	16.0	11.00	0.18	1.10	0.90	1								•
16ER 72 UN IC908	9.52	72.0	16.49	0.05	0.40	0.70	1								•
16ER 64 UN IC250	9.52	64.0	16.49	0.06	0.40	0.60	1			•					
16ER 56 UN IC908	9.52	56.0	16.49	0.05	0.40	0.65	1								•
16ER 48 UN IC908	9.52	48.0	16.49	0.05	0.60	0.60	1								•
16EL 40 UN IC250	9.52	40.0	16.49	0.10	0.50	0.60	1			•					
16ER 40 UN IC08	9.52	40.0	16.49	0.10	0.50	0.60	1				•				
16ER 40 UN IC508	9.52	40.0	16.49	0.10	0.50	0.60	1					•			
16ER 40 UN IC908	9.52	40.0	16.49	0.10	0.50	0.60	1								•
16EL 36 UN IC908	9.52	36.0	16.49	0.07	0.60	0.60	1								•
16ER 36 UN IC908	9.52	36.0	16.49	0.08	0.60	0.60	1								•
16ER/L 32 UN IC908	9.52	32.0	16.49	0.10	0.60	0.60	1								•
16ER 32 UN IC1007	9.52	32.0	16.49	0.10	0.60	0.60	1								•
16ER 32 UN IC250	9.52	32.0	16.49	0.10	0.60	0.60	1			•					
16ER/L 28 UN IC908	9.52	28.0	16.49	0.11	0.70	0.60	1								•
16ER 28 UN IC08	9.52	28.0	16.49	0.11	0.70	0.60	1				•				
16ER 28 UN IC1007	9.52	28.0	16.49	0.11	0.70	0.60	1								•
16ER 28 UN IC250	9.52	28.0	16.49	0.11	0.70	0.60	1			•					
16ER 27 UN IC50M	9.52	27.0	16.49	0.13	0.70	0.70	1		•						
16ER 27 UN IC908	9.52	27.0	16.49	0.13	0.70	0.70	1								•
16ER/L 24 UN IC908	9.52	24.0	16.49	0.13	0.80	0.70	1								•
16ER 24 UN IC08	9.52	24.0	16.49	0.13	0.80	0.70	1				•				
16ER 24 UN IC1007	9.52	24.0	16.49	0.13	0.80	0.70	1								•
16ER 24 UN IC250	9.52	24.0	16.49	0.13	0.80	0.70	1			•					
16ER 24 UN 2M IC250	9.52	24.0	16.49	0.15	1.70	1.10	2			•					
16ERB 24 UN IC908 (1)	9.52	24.0	16.49	0.13	0.80	0.70	1								•
16ERM 24 UN IC1007	9.52	24.0	16.49	0.11	0.80	0.70	1								•
16ERM 24 UN IC250 (1)	9.52	24.0	16.49	0.11	0.80	0.70	1			•					
16ERM 24 UN IC908 (1)	9.52	24.0	16.49	0.11	0.80	0.70	1								•
16EL 20 UN IC250	9.52	20.0	16.49	0.16	0.90	0.80	1			•					
16EL 20 UN IC08	9.52	20.0	16.49	0.16	0.80	0.90	1				•				
16EL 20 UN IC908	9.52	20.0	16.49	0.16	0.80	0.90	1								•

• For Insert Identification System, see page 714 • Tolerance: Class 2A • For threading between walls use GRIP-type insert TIP-UN

• For technical information and detailed cutting data, see pages 809-825

(1) With pressed chipformer.

(2) Multi-tooth

(3) Threads per inch

(4) Number of teeth per corner

For tools, see pages: C#-SER/L (799) • NQCH-SER/L-JHP (800) • SBTT#-16ER/L-JHP (418) • SER-D (800) • SER/L (798) • SER/L-JHP (799) • SER/L-JHP-MC (800)

Continued

ISCAR THREAD

ER/L-UN

External American UN Full Profile (UN, UNC, UNF, UNEF) Laydown Threading Inserts for General Applications

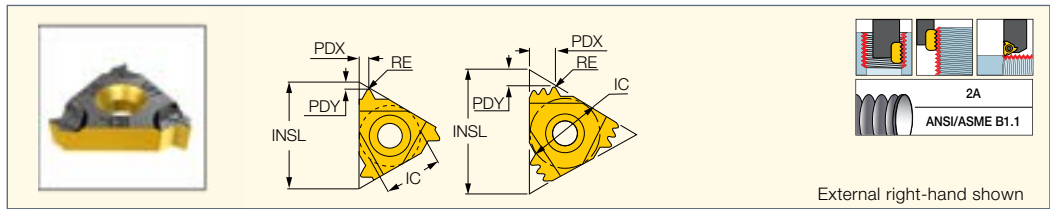

External right-hand shown

Designation	Dimensions							Tough ← Hard							
	IC	TPI ⁽³⁾	INSL	RE	PDX	PDY	CICT ⁽⁴⁾	IC228	IC50M	IC250	IC08	IC508	IC808	IC908	IC1007
16ER 20 UN IC08	9.52	20.0	16.49	0.16	0.90	0.80	1				•				
16ER 20 UN IC1007	9.52	20.0	16.49	0.16	0.90	0.80	1								•
16ER 20 UN IC250	9.52	20.0	16.49	0.16	0.90	0.80	1			•					
16ER 20 UN IC908	9.52	20.0	16.49	0.16	0.90	0.80	1							•	
16ERB 20 UN IC908 ⁽¹⁾	9.52	20.0	16.49	0.16	0.90	0.80	1							•	
16ERM 20 UN IC1007 ⁽¹⁾	9.52	20.0	16.49	0.14	0.90	0.80	1								•
16ERM 20 UN IC250 ⁽¹⁾	9.52	20.0	16.49	0.14	0.90	0.80	1			•					
16ERM 20 UN IC808 ⁽¹⁾	9.52	20.0	16.49	0.14	0.90	0.80	1						•		
16ERM 20 UN IC908 ⁽¹⁾	9.52	20.0	16.49	0.14	0.90	0.80	1							•	
16EL 18 UN IC08	9.52	18.0	16.49	0.17	1.00	0.80	1				•				
16ER/L 18 UN IC908	9.52	18.0	16.49	0.17	0.80	0.70	1							•	
16ER 18 UN IC1007	9.52	18.0	16.49	0.17	0.80	0.70	1								•
16ER 18 UN IC250	9.52	18.0	16.49	0.17	0.80	0.70	1			•					
16ER 18 UN IC50M	9.52	18.0	16.49	0.17	0.80	0.70	1		•						
16ER 18 UN 2M IC908	9.52	18.0	16.49	0.20	2.25	1.50	2							•	
16ERB 18 UN IC908 ⁽¹⁾	9.52	18.0	16.49	0.18	0.80	0.70	1							•	
16ERM 18 UN IC1007 ⁽¹⁾	9.52	18.0	16.49	0.15	1.00	0.80	1								•
16ERM 18 UN IC250 ⁽¹⁾	9.52	18.0	16.49	0.15	1.00	0.80	1			•					
16ERM 18 UN IC808 ⁽¹⁾	9.52	18.0	16.49	0.15	1.00	0.80	1						•		
16ERM 18 UN IC908 ⁽¹⁾	9.52	18.0	16.49	0.15	1.00	0.80	1							•	
16EL 16 UN IC250	9.52	16.0	16.49	0.23	1.20	1.10	1			•					
16EL 16 UN IC908	9.52	16.0	16.49	0.23	1.15	1.10	1							•	
16ER 16 UN IC1007	9.52	16.0	16.49	0.23	1.15	1.00	1								•
16ER 16 UN IC228	9.52	16.0	16.49	0.23	1.15	1.10	1	•							
16ER 16 UN IC250	9.52	16.0	16.49	0.23	1.15	1.10	1			•					
16ER 16 UN IC908	9.52	16.0	16.49	0.23	1.15	1.00	1							•	
16ER 16 UN 2M IC908 ⁽²⁾	9.52	16.0	16.49	0.09	2.30	1.50	2							•	
16ERB 16 UN IC908 ⁽¹⁾	9.52	16.0	16.49	0.23	1.10	1.15	1							•	
16ERM 16 UN IC1007 ⁽¹⁾	9.52	16.0	16.49	0.23	1.10	1.00	1								•
16ERM 16 UN IC250 ⁽¹⁾	9.52	16.0	16.49	0.23	1.10	1.00	1			•					
16ERM 16 UN IC808 ⁽¹⁾	9.52	16.0	16.49	0.23	1.10	1.00	1						•		
16ERM 16 UN IC908 ⁽¹⁾	9.52	16.0	16.49	0.23	1.10	1.00	1							•	
16ER/L 14 UN IC250	9.52	14.0	16.49	0.23	1.20	1.00	1			•					
16EL 14 UN IC508	9.52	14.0	16.49	0.23	1.20	1.00	1					•			
16ER 14 UN IC1007	9.52	14.0	16.49	0.23	1.20	1.00	1								•
16ER 14 UN IC908	9.52	14.0	16.49	0.23	1.20	1.00	1							•	
16ER 14 UN 2M IC908 ⁽²⁾	9.52	14.0	16.49	0.09	2.60	1.60	2							•	
16ERB 14 UN IC908 ⁽¹⁾	9.52	14.0	16.49	0.23	1.20	1.00	1							•	
16ERM 14 UN IC1007 ⁽¹⁾	9.52	14.0	16.49	0.22	1.20	1.00	1								•
16ERM 14 UN IC250 ⁽¹⁾	9.52	14.0	16.49	0.22	1.20	1.00	1			•					
16ERM 14 UN IC808 ⁽¹⁾	9.52	14.0	16.49	0.22	1.20	1.00	1						•		
16ERM 14 UN IC908 ⁽¹⁾	9.52	14.0	16.49	0.22	1.20	1.00	1							•	
16EL 13 UN IC250	9.52	13.0	16.49	0.24	1.30	1.00	1			•					
16ER/L 13 UN IC908	9.52	13.0	16.49	0.24	1.20	1.00	1							•	
16ER 13 UN IC08	9.52	13.0	16.49	0.24	1.20	1.00	1				•				
16ER 13 UN IC250	9.52	13.0	16.49	0.24	1.20	1.00	1			•					
16ERB 13 UN IC908 ⁽¹⁾	9.52	13.0	16.49	0.25	1.20	0.90	1							•	
16ERM 13 UN IC908 ⁽¹⁾	9.52	13.0	16.49	0.24	1.30	1.00	1							•	

- For Insert Identification System, see page 714 • Tolerance: Class 2A • For threading between walls use GRIP-type insert TIP-UN
- For technical information and detailed cutting data, see pages 809-825

⁽¹⁾ With pressed chipformer.

⁽²⁾ Multi-tooth

⁽³⁾ Threads per inch

⁽⁴⁾ Number of teeth per corner

For tools, see pages: C#-SER/L (799) • NQCH-SER/L-JHP (800) • SBTT#-16ER/L-JHP (418) • SER-D (800) • SER/L (798) • SER/L-JHP (799) • SER/L-JHP-MC (800)

Continued

ISCAR THREAD

ER/L-UN

External American UN Full Profile (UN, UNC, UNF, UNEF) Laydown Threading Inserts for General Applications

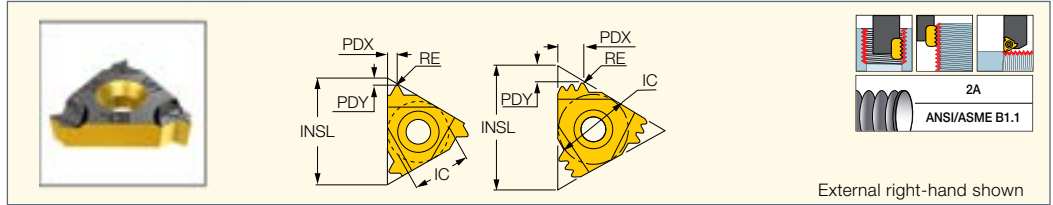

External right-hand shown

Designation	Dimensions							Tough ↔ Hard							
	IC	TPI ⁽³⁾	INSL	RE	PDX	PDY	CICT ⁽⁴⁾	IC228	IC50M	IC250	IC08	IC508	IC808	IC908	IC1007
16EL 12 UN IC250	9.52	12.0	16.49	0.27	1.20	1.10	1			•					
16EL 12 UN IC908	9.52	12.0	16.49	0.27	1.20	1.10	1							•	
16ER 12 UN IC08	9.52	12.0	16.49	0.30	1.25	1.00	1				•				
16ER 12 UN IC1007	9.52	12.0	16.49	0.30	1.25	1.00	1								•
16ER 12 UN IC250	9.52	12.0	16.49	0.30	1.30	1.00	1			•					
16ER 12 UN IC908	9.52	12.0	16.49	0.30	1.25	1.00	1							•	
16ER 12 UN 2M IC908 ⁽²⁾	9.52	12.0	16.49	0.27	3.40	2.20	2							•	
16ERB 12 UN IC908 ⁽¹⁾	9.52	12.0	16.49	0.27	1.20	0.90	1							•	
16ERM 12 UN IC1007 ⁽¹⁾	9.52	12.0	16.49	0.25	1.40	1.10	1								•
16ERM 12 UN IC250 ⁽¹⁾	9.52	12.0	16.49	0.25	1.40	1.10	1			•					
16ERM 12 UN IC50M ⁽¹⁾	9.52	12.0	16.49	0.25	1.40	1.10	1	•							
16ERM 12 UN IC808 ⁽¹⁾	9.52	12.0	16.49	0.25	1.40	1.10	1					•			
16ERM 12 UN IC908 ⁽¹⁾	9.52	12.0	16.49	0.25	1.40	1.10	1							•	
16ER 11.5 UN IC250	9.52	11.5	16.49	0.27	1.50	1.20	1			•					
16ER 11.5 UN IC908	9.52	11.5	16.49	0.27	1.50	1.20	1							•	
16EL 11 UN IC908	9.52	11.0	16.49	0.28	1.50	1.10	1							•	
16ER 11 UN IC250	9.52	11.0	16.49	0.29	1.50	1.10	1			•					
16ER 11 UN IC908	9.52	11.0	16.49	0.29	1.50	1.10	1							•	
16ERB 11 UN IC908 ⁽¹⁾	9.52	11.0	16.49	0.29	1.50	1.10	1							•	
16EL 10 UN IC250	9.52	10.0	16.49	0.37	1.50	1.10	1			•					
16ER/L 10 UN IC908	9.52	10.0	16.49	0.37	1.50	1.10	1							•	
16ER 10 UN IC08	9.52	10.0	16.49	0.37	1.50	1.10	1				•				
16ER 10 UN IC1007	9.52	10.0	16.49	0.37	1.50	1.10	1								•
16ER 10 UN IC250	9.52	10.0	16.49	0.37	1.50	1.10	1			•					
16ERB 10 UN IC908 ⁽¹⁾	9.52	10.0	16.49	0.37	1.50	1.10	1							•	
16ERM 10 UN IC908	9.52	10.0	16.49	0.32	1.50	1.10	1							•	
16ER 9 UN IC908	9.52	9.0	16.49	0.35	1.60	1.30	1							•	
16ERB 9 UN IC908 ⁽¹⁾	9.52	9.0	16.49	0.35	1.60	1.30	1							•	
16EL 8 UN IC250	9.52	8.0	16.49	0.40	1.60	1.20	1			•					
16ER/L 8 UN IC908	9.52	8.0	16.49	0.40	1.60	1.20	1							•	
16ER 8 UN IC1007	9.52	8.0	16.49	0.40	1.60	1.20	1								•
16ER 8 UN IC250	9.52	8.0	16.49	0.40	1.60	1.20	1			•					
16ERB 8 UN IC908 ⁽¹⁾	9.52	8.0	16.49	0.43	1.60	1.20	1							•	
16ERM 8 UN IC1007	9.52	8.0	16.49	0.41	1.60	1.20	1								•
16ERM 8 UN IC250 ⁽¹⁾	9.52	8.0	16.49	0.41	1.60	1.20	1			•					
16ERM 8 UN IC908 ⁽¹⁾	9.52	8.0	16.49	0.41	1.60	1.20	1							•	
22ER 13 UN 3M IC250	12.70	13.0	22.00	0.28	4.70	2.90	3			•					
22ER 12 UN 2M IC908 ⁽²⁾	12.70	12.0	22.00	0.27	3.40	2.20	2							•	
22ER 12 UN 3M IC250	12.70	12.0	22.00	0.30	5.15	3.20	3			•					
22ER 12 UN 3M IC50M ⁽²⁾	12.70	12.0	22.00	0.30	5.20	3.20	3	•							
22ER 12 UN 3M IC908 ⁽²⁾	12.70	12.0	22.00	0.30	5.20	3.20	3							•	
22ER 7 UN IC250	12.70	7.0	22.00	0.47	2.30	1.60	1			•					
22ER 7 UN IC908	12.70	7.0	22.00	0.47	2.30	1.60	1							•	
22ER 6 UN IC08	12.70	6.0	22.00	0.67	2.30	1.60	1				•				
22ER 6 UN IC908	12.70	6.0	22.00	0.56	2.30	1.60	1							•	
22ER 5 UN IC250	12.70	5.0	22.00	0.67	2.50	1.70	1			•					
22ER 5 UN IC50M	12.70	5.0	22.00	0.67	2.50	1.70	1	•							
22ER 5 UN IC908	12.70	5.0	22.00	0.69	2.50	1.80	1							•	

- For Insert Identification System, see page 714 • Tolerance: Class 2A • For threading between walls use GRIP-type insert TIP-UN
- For technical information and detailed cutting data, see pages 809-825

⁽¹⁾ With pressed chipformer.

⁽²⁾ Multi-tooth

⁽³⁾ Threads per inch

⁽⁴⁾ Number of teeth per corner

For tools, see pages: C#-SER/L (799) • NQCH-SER/L-JHP (800) • SBTT#-16ER/L-JHP (418) • SER-D (800) • SER/L (798) • SER/L-JHP (799) • SER/L-JHP-MC (800)

Continued

ISCAR THREAD

ER/L-UN

External American UN Full Profile (UN, UNC, UNF, UNEF) Laydown Threading Inserts for General Applications

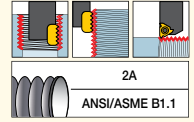
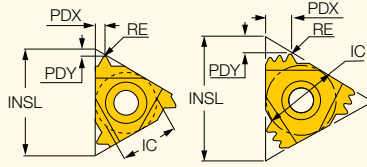

External right-hand shown

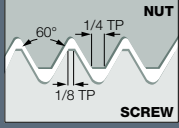

Dimensions

Tough ↔ Hard

Designation	IC	TPI ⁽³⁾	INSL	RE	PDX	PDY	CICT ⁽⁴⁾	Tough ↔ Hard											
								IC228	IC50M	IC250	IC08	IC508	IC808	IC908	IC1007				
27ER 8 UN 2M IC908 ⁽²⁾	15.88	8.0	27.50	0.41	4.90	3.10	2												
27ER 4.5 UN IC908	15.88	4.5	27.50	0.75	2.70	1.90	1												
27ER 4 UN IC08	15.88	4.0	27.50	0.85	2.90	2.00	1												
27ER 4 UN IC250	15.88	4.0	27.50	0.85	2.90	2.00	1												
27ER 4 UN IC50M	15.88	4.0	27.50	0.85	2.90	2.00	1												
27ER 4 UN IC908	15.88	4.0	27.50	0.85	2.90	2.00	1												

- For Insert Identification System, see page 714
- Tolerance: Class 2A
- For threading between walls use GRIP-type insert TIP-UN
- For technical information and detailed cutting data, see pages 809-825

- ⁽¹⁾ With pressed chipformer.
- ⁽²⁾ Multi-tooth
- ⁽³⁾ Threads per inch
- ⁽⁴⁾ Number of teeth per corner

For tools, see pages: C#-SER/L (799) • NQCH-SER/L-JHP (800) • SBTT#-16ER/L-JHP (418) • SER-D (800) • SER/L (798) • SER/L-JHP (799) • SER/L-JHP-MC (800)



IR/L-UN
Internal American UN Full Profile (UN, UNC, UNF, UNEF) Laydown Threading Inserts for General Applications

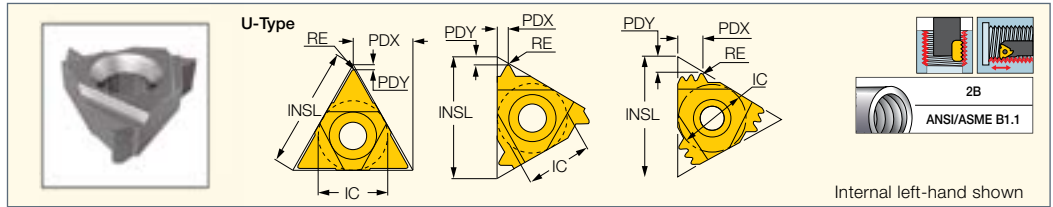

Designation	Dimensions							Tough ↔ Hard								
	IC	TPI ⁽⁴⁾	INSL	RE	PDX	PDY	CICT ⁽⁵⁾	IC228	IC928	IC50M	IC250	IC08	IC508	IC808	IC908	IC1007
06IR 32 UN IC228	4.00	32.0	6.88	0.05	0.50	0.60	1	●								
06IR 28 UN IC908	4.00	28.0	6.88	0.07	0.50	0.60	1								●	
06IR 28 UN IC228	4.00	28.0	6.88	0.07	0.50	0.60	1	●								
06IL 24 UN IC228	4.00	24.0	6.88	0.08	0.60	0.60	1	●								
06IR 24 UN IC228	4.00	24.0	6.88	0.08	0.60	0.60	1	●								
06IR 24 UN IC908	4.00	24.0	6.88	0.08	0.60	0.60	1								●	
06IR 20 UN IC228	4.00	20.0	6.88	0.09	0.60	0.60	1	●								
06IL 18 UN IC228	4.00	18.0	6.88	0.07	0.70	0.60	1	●								
06IR 18 UN IC228	4.00	18.0	6.88	0.10	0.70	0.60	1	●								
08IR 32 UN IC228	5.00	32.0	8.24	0.06	0.50	0.50	1	●								
08IL 28 UN IC228	5.00	28.0	8.24	0.07	0.60	0.50	1	●								
08IR 28 UN IC228	5.00	28.0	8.24	0.07	0.60	0.50	1	●								
08IR 28 UN IC908	5.00	28.0	8.24	0.07	0.60	0.50	1								●	
08IR 27 UN IC228	5.00	27.0	8.24	0.08	0.50	0.50	1	●								
08IL 24 UN IC228	5.00	24.0	8.24	0.08	0.55	0.57	1	●								
08IR 24 UN IC228	5.00	24.0	8.24	0.08	0.60	0.60	1	●								
08IR 24 UN IC908	5.00	24.0	8.24	0.08	0.55	0.60	1								●	
08IL 20 UN IC228	5.00	20.0	8.24	0.08	0.70	0.70	1	●								
08IR 20 UN IC228	5.00	20.0	8.24	0.09	0.65	0.65	1	●								
08IR 18 UN IC228	5.00	18.0	8.24	0.12	0.70	0.50	1	●								
08IR 18 UN IC908	5.00	18.0	8.24	0.12	0.70	0.55	1								●	
08IR 16 UN IC228	5.00	16.0	8.24	0.12	0.70	0.60	1	●								
08IR 14 UN IC228	5.00	14.0	8.24	0.13	0.72	0.54	1	●								
08IR 14 UN IC908	5.00	14.0	8.24	0.13	0.72	0.54	1								●	
08IR 13 UN IC908	5.00	13.0	8.24	0.14	0.85	0.60	1								●	
08IR 13 UN IC228	5.00	13.0	8.24	0.14	0.85	0.60	1	●								
08UIRL 13 UN IC908	5.00	13.0	8.66	0.14	4.33	0.75	1								●	
08UIRL 12 UN IC928	5.00	12.0	8.66	0.13	4.33	0.80	1		●							
08UIRL 11 UN IC228	5.00	11.0	8.66	0.10	4.33	0.90	1	●								
11IR 64 UN IC250	6.35	64.0	11.00	0.04	0.40	0.78	1				●					
11IR 48 UN IC250	6.35	48.0	11.00	0.04	0.92	0.77	1				●					
11IR 44 UN IC250	6.35	44.0	11.00	0.04	0.92	0.77	1				●					
11IR 40 UN IC250	6.35	40.0	11.00	0.05	0.92	0.76	1				●					
11IR 36 UN IC908	6.35	36.0	11.00	0.06	0.60	0.60	1								●	
11IL 32 UN IC908	6.35	32.0	11.00	0.04	0.60	0.60	1								●	
11IR 32 UN IC908	6.35	32.0	11.00	0.05	0.60	0.60	1								●	
11IRB 32 UN IC908	6.35	32.0	11.00	0.04	0.60	0.60	1								●	
11IL 28 UN IC908	6.35	28.0	11.00	0.04	0.70	0.60	1								●	
11IR 28 UN IC908	6.35	28.0	11.00	0.05	0.60	0.60	1								●	
11IRB 28 UN IC908	6.35	28.0	11.00	0.05	0.60	0.60	1								●	
11IL 24 UN IC908	6.35	24.0	11.00	0.07	0.80	0.80	1								●	
11IR 24 UN IC1007	6.35	24.0	11.00	0.07	0.80	0.80	1									●
11IR 24 UN IC908	6.35	24.0	11.00	0.07	0.80	0.70	1								●	
11IRB 24 UN IC908	6.35	24.0	11.00	0.08	0.60	0.60	1								●	
11IL 20 UN IC908	6.35	20.0	11.00	0.09	0.90	0.80	1								●	
11IR 20 UN IC908	6.35	20.0	11.00	0.09	0.90	0.80	1								●	
11IRB 20 UN IC908	6.35	20.0	11.00	0.09	0.90	0.80	1								●	
11IL 18 UN IC908	6.35	18.0	11.00	0.10	1.00	0.90	1								●	
11IR 18 UN IC1007	6.35	18.0	11.00	0.07	1.00	0.80	1									●
11IR 18 UN IC250	6.35	18.0	11.00	0.10	1.00	0.90	1				●					
11IR 18 UN IC908	6.35	18.0	11.00	0.10	1.00	0.90	1								●	
11IRB 18 UN IC908	6.35	18.0	11.00	0.10	1.00	0.90	1								●	

• For Insert Identification System, see page 714 • Tolerance: class 2B, ANSI B1, 3M-1986. • For technical information and detailed cutting data, see pages 809-825

(1) With pressed chipformer

(2) Multi-tooth

(3) With pressed chipformer.

(4) Threads per inch

(5) Number of teeth per corner

For tools, see pages: AVC-D-SIR/L (805) • C#-SIR/L (803) • MGSIR/L (156) • PICIN-A-SIR/L (466) • PICIN-MGSIR/L (466) • SIR/L (801)

Continued

ISCAR THREAD

IR/L-UN

Internal American UN Full Profile (UN, UNC, UNF, UNEF) Laydown Threading Inserts for General Applications

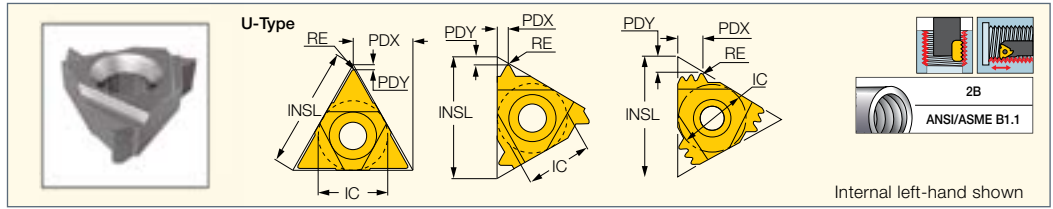

Designation	Dimensions							Tough ↔ Hard								
	IC	TPI ⁽⁴⁾	INSL	RE	PDX	PDY	CICT ⁽⁵⁾	IC228	IC928	IC50M	IC250	IC08	IC508	IC808	IC908	IC1007
11IL 16 UN IC908	6.35	16.0	11.00	0.11	1.00	0.90	1									
11IR 16 UN IC250	6.35	16.0	11.00	0.09	1.10	0.90	1				•					
11IR 16 UN IC1007	6.35	16.0	11.00	0.11	1.00	0.90	1									•
11IR 16 UN IC908	6.35	16.0	11.00	0.11	1.00	0.90	1								•	
11IRB 16 UN IC908	6.35	16.0	11.00	0.11	1.00	0.90	1								•	
11IL 14 UN IC250	6.35	14.0	11.00	0.10	1.10	0.90	1				•					
11IL 14 UN IC908	6.35	14.0	11.00	0.10	1.10	0.90	1								•	
11IR 14 UN IC250	6.35	14.0	11.00	0.10	1.10	0.90	1				•					
11IR 14 UN IC50M	6.35	14.0	11.00	0.13	1.00	0.90	1			•						
11IR 14 UN IC908	6.35	14.0	11.00	0.13	1.00	0.90	1								•	
11IRB 14 UN IC908	6.35	14.0	11.00	0.13	1.00	0.90	1								•	
11IR 13 UN IC908	6.35	13.0	11.00	0.15	0.95	0.75	1								•	
11IR 12 UN IC250	6.35	12.0	11.00	0.15	1.00	0.75	1				•					
11IR 12 UN IC908	6.35	12.0	11.00	0.15	1.00	0.75	1								•	
11IRB 12 UN IC908	6.35	12.0	11.00	0.15	1.00	0.75	1								•	
11IR 11 UN IC250	6.35	11.0	11.00	0.14	1.10	0.80	1				•					
11IR 11 UN IC908	6.35	11.0	11.00	0.14	1.00	0.80	1								•	
11IR 10 UN IC908	6.35	10.0	11.00	0.19	1.23	0.85	1								•	
16IR 64 UN IC250	9.52	64.0	16.49	0.04	0.40	0.58	1				•					
16IR 40 UN IC908	9.52	40.0	16.49	0.05	0.40	0.60	1								•	
16IR 36 UN IC908	9.52	36.0	16.49	0.06	0.60	0.58	1								•	
16IR 32 UN IC250	9.52	32.0	16.49	0.04	0.60	0.60	1				•					
16IR 32 UN IC908	9.52	32.0	16.49	0.05	0.60	0.60	1								•	
16IL 28 UN IC908	9.52	28.0	16.49	0.04	0.70	0.60	1								•	
16IR 28 UN IC908	9.52	28.0	16.49	0.05	0.60	0.60	1								•	
16IL 24 UN 2M IC908	9.52	24.0	16.49	0.08	1.50	1.30	2								•	
16IR 24 UN IC250	9.52	24.0	16.49	0.05	0.80	0.70	1				•					
16IR 24 UN IC908	9.52	24.0	16.49	0.08	0.80	0.70	1								•	
16IRB 24 UN IC908 (1)	9.52	24.0	16.49	0.07	0.80	0.70	1								•	
16IL 20 UN IC250	9.52	20.0	16.49	0.06	0.90	0.80	1				•					
16IL 20 UN IC908	9.52	20.0	16.49	0.09	0.90	0.80	1								•	
16IR 20 UN IC08	9.52	20.0	16.49	0.09	0.90	0.80	1					•				
16IR 20 UN IC1007	9.52	20.0	16.49	0.09	0.90	0.80	1									•
16IR 20 UN IC250	9.52	20.0	16.49	0.06	0.90	0.80	1				•					
16IR 20 UN IC50M	9.52	20.0	16.49	0.09	0.90	0.80	1			•						
16IR 20 UN IC908	9.52	20.0	16.49	0.09	0.90	0.80	1								•	
16IR 20 UN 2M IC250	9.52	20.0	16.49	0.11	2.00	1.60	2				•					
16IRB 20 UN IC908 (1)	9.52	20.0	16.49	0.09	0.80	0.80	1								•	
16IRM 20 UN IC1007	9.52	20.0	16.49	0.06	0.90	0.80	1									•
16IRM 20 UN IC908 (1)	9.52	20.0	16.49	0.06	0.90	0.80	1								•	
16IL 18 UN IC908	9.52	18.0	16.49	0.08	0.80	0.70	1								•	
16IR 18 UN IC1007	9.52	18.0	16.49	0.12	0.80	0.70	1									•
16IR 18 UN IC250	9.52	18.0	16.49	0.10	1.00	0.80	1				•					
16IR 18 UN IC908	9.52	18.0	16.49	0.10	1.00	0.80	1								•	
16IRB 18 UN IC908 (1)	9.52	18.0	16.49	0.12	0.80	0.70	1								•	
16IRM 18 UN IC808 (1)	9.52	18.0	16.49	0.08	1.00	0.80	1						•			
16IRM 18 UN IC908 (1)	9.52	18.0	16.49	0.08	1.00	0.80	1								•	
16IL 16 UN IC908	9.52	16.0	16.49	0.11	1.20	1.00	1								•	
16IR 16 UN IC250	9.52	16.0	16.49	0.11	1.20	0.90	1				•					
16IR 16 UN IC908	9.52	16.0	16.49	0.11	1.20	0.90	1								•	
16IR 16 UN-2M IC508 (2)	9.52	16.0	16.49	0.09	2.30	1.50	2					•				
16IR 16 UN-2M IC908	9.52	16.0	16.49	0.09	2.30	1.50	2								•	

• For Insert Identification System, see page 714 • Tolerance: class 2B, ANSI B1, 3M-1986. • For technical information and detailed cutting data, see pages 809-825

(1) With pressed chipformer

(2) Multi-tooth

(3) With pressed chipformer.

(4) Threads per inch

(5) Number of teeth per corner

For tools, see pages: AVC-D-SIR/L (805) • C#-SIR/L (803) • MGSIR/L (156) • PICIN-A-SIR/L (466) • PICIN-MGSIR/L (466) • SIR/L (801)

Continued

ISCARTHREAD

IR/L-UN

Internal American UN Full Profile (UN, UNC, UNF, UNEF) Laydown Threading Inserts for General Applications

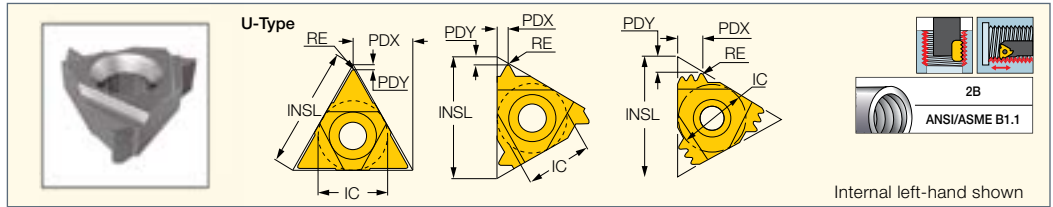

Designation	Dimensions							Tough ↔ Hard								
	IC	TPI ⁽⁴⁾	INSL	RE	PDX	PDY	CICT ⁽⁵⁾	IC228	IC928	IC50M	IC250	IC08	IC508	IC808	IC908	IC1007
16IRB 16 UN IC908 ⁽³⁾	9.52	16.0	16.49	0.11	1.20	0.90	1								•	
16IRM 16 UN IC1007 ⁽¹⁾	9.52	16.0	16.49	0.09	1.10	0.90	1									•
16IRM 16 UN IC250 ⁽¹⁾	9.52	16.0	16.49	0.09	1.10	0.90	1				•					
16IRM 16 UN IC908 ⁽¹⁾	9.52	16.0	16.49	0.09	1.10	0.90	1								•	
16IL 14 UN IC250	9.52	14.0	16.49	0.10	1.20	0.90	1				•					
16IL 14 UN IC908	9.52	14.0	16.49	0.13	1.20	0.90	1				•					
16IR 14 UN IC250	9.52	14.0	16.49	0.13	1.20	0.90	1				•					
16IR 14 UN IC908	9.52	14.0	16.49	0.13	1.20	0.90	1								•	
16IRB 14 UN IC908 ⁽¹⁾	9.52	14.0	16.49	0.13	1.20	0.90	1								•	
16IRM 14 UN IC1007	9.52	14.0	16.49	0.11	1.20	0.90	1									•
16IRM 14 UN IC250 ⁽¹⁾	9.52	14.0	16.49	0.11	1.20	0.90	1				•					
16IRM 14 UN IC808	9.52	14.0	16.49	0.11	1.20	0.90	1						•			
16IRM 14 UN IC908 ⁽¹⁾	9.52	14.0	16.49	0.11	1.20	0.90	1								•	
16IL 13 UN IC250	9.52	13.0	16.49	0.14	1.00	1.50	1				•					
16IR 13 UN IC908	9.52	13.0	16.49	0.14	1.00	1.50	1								•	
16IL 12 UN IC250	9.52	12.0	16.49	0.15	1.40	1.10	1				•					
16IL 12 UN IC908	9.52	12.0	16.49	0.15	1.10	1.00	1								•	
16IR 12 UN IC08	9.52	12.0	16.49	0.15	1.10	1.00	1					•				
16IR 12 UN IC1007	9.52	12.0	16.49	0.15	1.10	1.00	1									•
16IR 12 UN IC250	9.52	12.0	16.49	0.15	1.10	1.00	1				•					
16IR 12 UN IC908	9.52	12.0	16.49	0.15	1.10	1.00	1								•	
16IRB 12 UN IC908 ⁽¹⁾	9.52	12.0	16.49	0.13	1.20	1.00	1								•	
16IRM 12 UN IC1007 ⁽¹⁾	9.52	12.0	16.49	0.12	1.40	1.10	1									•
16IRM 12 UN IC250 ⁽¹⁾	9.52	12.0	16.49	0.12	1.40	1.10	1				•					
16IRM 12 UN IC808 ⁽¹⁾	9.52	12.0	16.49	0.12	1.40	1.10	1						•			
16IRM 12 UN IC908 ⁽¹⁾	9.52	12.0	16.49	0.12	1.40	1.10	1								•	
16IR 11.5 UN IC908	9.52	11.5	16.49	0.14	1.10	1.00	1								•	
16IL 11 UN IC908	9.52	11.0	16.49	0.18	1.00	1.00	1								•	
16IR 11 UN IC908	9.52	11.0	16.49	0.18	1.00	1.00	1								•	
16IL 10 UN IC250	9.52	10.0	16.49	0.15	1.50	1.10	1				•					
16IL 10 UN IC908	9.52	10.0	16.49	0.15	1.50	1.10	1								•	
16IR 10 UN IC250	9.52	10.0	16.49	0.15	1.50	1.10	1				•					
16IR 10 UN IC908	9.52	10.0	16.49	0.15	1.50	1.10	1								•	
16IRB 10 UN IC908 ⁽¹⁾	9.52	10.0	16.49	0.15	1.50	1.10	1								•	
16IR 9 UN IC908	9.52	9.0	16.49	0.17	1.70	1.20	1								•	
16IL 8 UN IC08	9.52	8.0	16.49	0.22	1.45	1.04	1					•				
16IL 8 UN IC250	9.52	8.0	16.49	0.23	1.50	1.10	1				•					
16IL 8 UN IC908	9.52	8.0	16.49	0.23	1.50	1.10	1								•	
16IR 8 UN IC08	9.52	8.0	16.49	0.23	1.50	1.10	1					•				
16IR 8 UN IC1007	9.52	8.0	16.49	0.23	1.50	1.10	1									•
16IR 8 UN IC250	9.52	8.0	16.49	0.23	1.50	1.10	1				•					
16IR 8 UN IC908	9.52	8.0	16.49	0.23	1.50	1.10	1								•	
16IRB 8 UN IC908 ⁽¹⁾	9.52	8.0	16.49	0.23	1.50	1.10	1								•	
16IRM 8 UN IC1007	9.52	8.0	16.49	0.20	1.50	1.10	1									•
16IRM 8 UN IC250 ⁽¹⁾	9.52	8.0	16.49	0.20	1.50	1.10	1				•					
16IRM 8 UN IC808 ⁽¹⁾	9.52	8.0	16.49	0.20	1.50	1.10	1						•			
16IRM 8 UN IC908 ⁽¹⁾	9.52	8.0	16.49	0.20	1.50	1.10	1								•	
22IR 16 UN 3M IC908 ⁽²⁾	12.70	16.0	22.00	0.07	4.00	2.50	3								•	
22IR 12 UN 2M IC908 ⁽²⁾	12.70	12.0	22.00	0.15	2.95	2.25	2								•	
22IR 12 UN 3M IC908 ⁽²⁾	12.70	12.0	22.00	0.15	5.20	3.15	3								•	
22IL 7 UN IC908	12.70	7.0	22.00	0.22	2.30	1.60	1								•	
22IR 7 UN IC228	12.70	7.0	22.00	0.22	2.30	1.60	1	•								

• For Insert Identification System, see page 714 • Tolerance: class 2B, ANSI B1, 3M-1986. • For technical information and detailed cutting data, see pages 809-825

⁽¹⁾ With pressed chipformer

⁽²⁾ Multi-tooth

⁽³⁾ With pressed chipformer.

⁽⁴⁾ Threads per inch

⁽⁵⁾ Number of teeth per corner

For tools, see pages: AVC-D-SIR/L (805) • C#-SIR/L (803) • MGSIR/L (156) • PICIN-A-SIR/L (466) • PICIN-MGSIR/L (466) • SIR/L (801)

Continued

ISCAR THREAD

IR/L-UN

Internal American UN Full Profile (UN, UNC, UNF, UNEF) Laydown Threading Inserts for General Applications

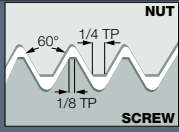
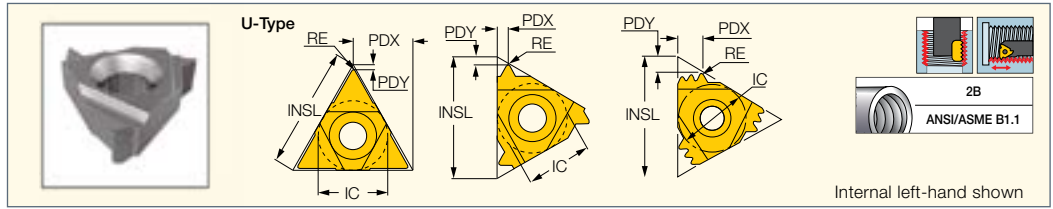

Designation	Dimensions							Tough ↔ Hard								
	IC	TPI ⁽⁴⁾	INSL	RE	PDX	PDY	CICT ⁽⁵⁾	IC228	IC928	IC50M	IC250	IC08	IC508	IC808	IC908	IC1007
22IR 7 UN IC250	12.70	7.0	22.00	0.22	2.30	1.60	1				•					
22IR 7 UN IC908	12.70	7.0	22.00	0.22	2.30	1.60	1								•	
22IL 6 UN IC250	12.70	6.0	22.00	0.27	2.30	1.57	1				•					
22IL 6 UN IC908	12.70	6.0	22.00	0.27	2.30	1.57	1								•	
22IR 6 UN IC250	12.70	6.0	22.00	0.26	2.30	1.60	1				•					
22IR 6 UN IC908	12.70	6.0	22.00	0.26	2.30	1.60	1								•	
22IR 5 UN IC250	12.70	5.0	22.00	0.38	2.30	1.70	1				•					
22IR 5 UN IC908	12.70	5.0	22.00	0.38	2.30	1.70	1								•	
22UIRL 4.5 UN IC250	12.70	4.5	22.00	0.36	11.00	2.40	1				•					
27IR 8 UN 2M IC908 ⁽²⁾	15.88	8.0	27.50	0.19	4.90	3.10	2								•	
27IR 4.5 UN IC908	15.88	4.5	27.50	0.45	2.50	1.80	1								•	
27IR 4.5 UN IC250	15.88	4.5	27.50	0.45	2.50	1.80	1				•					
27IR 4 UN IC250	15.88	4.0	27.50	0.47	2.50	1.84	1				•					
27IR 4 UN IC908	15.88	4.0	27.50	0.47	2.50	1.90	1								•	

• For Insert Identification System, see page 714 • Tolerance: class 2B, ANSI B1, 3M-1986. • For technical information and detailed cutting data, see pages 809-825

(1) With pressed chipformer

(2) Multi-tooth

(3) With pressed chipformer.

(4) Threads per inch

(5) Number of teeth per corner

For tools, see pages: AVC-D-SIR/L (805) • C#-SIR/L (803) • MGSIR/L (156) • PICIN-A-SIR/L (466) • PICIN-MGSIR/L (466) • SIR/L (801)

PENTA 24-UN

American UN (UNC, UNF, UNEF) Precision Ground Full Profile Pentagonal External Inserts with a Chipformer

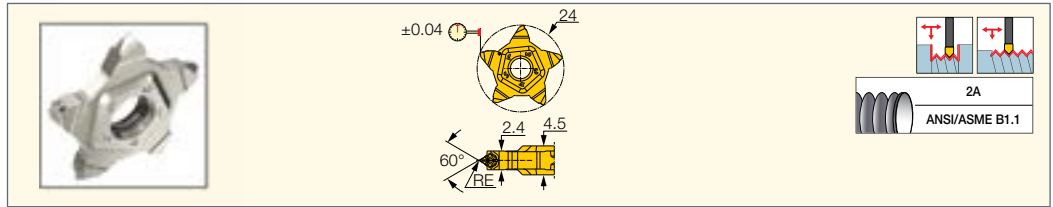

Designation	Dimensions		IC908
	TPI ⁽¹⁾	RE	
PENTA 24-24-UN IC908	24.0	0.13	●
PENTA 24-20-UN IC908	20.0	0.16	●
PENTA 24-18-UN IC908	18.0	0.18	●
PENTA 24-16-UN IC908	16.0	0.21	●
PENTA 24-14-UN IC908	14.0	0.23	●

• DMIN(inch)=5.435/TPI • Tolerance: Class 2A

⁽¹⁾ Threads per inch

For tools, see pages: NQCH-PCHR/L-24-JHP (348) • PCAD RE/LE-JHP (561) • PCADR/L (353) • PCADR/L-JHP (353) • PCHBR/L (355)

• PCHR/L-24 (346) • PCHR/L-24-JHP (347) • PCHR/L-24-JHP-MC (348)

CUTGRIP

ISCARTHREAD

TIP-P-UN

American UN (UNC, UNF, UNEF) Precision Ground External Double-Ended Full Profile Threading Inserts with a Chipformer

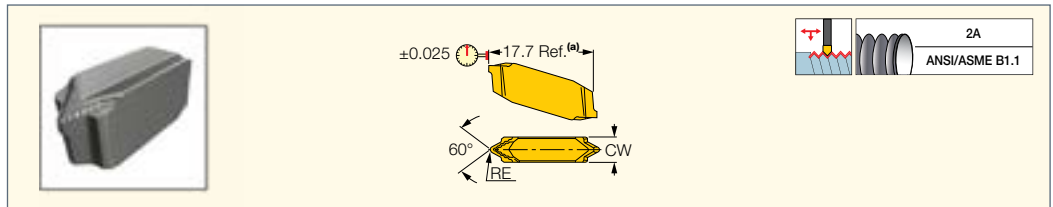

Designation	Dimensions				Tough ← Hard		
	CW	RE	RETOL ⁽¹⁾	TPI ⁽²⁾	IC08	IC808	IC908
TIP 2P32-UN IC08	2.40	0.10	0.030	32.0	●		
TIP 2P32-UN IC908	2.40	0.10	0.030	32.0			●
TIP 2P28-UN IC08	2.40	0.11	0.030	28.0	●		
TIP 2P28-UN IC908	2.40	0.11	0.030	28.0			●
TIP 2P24-UN IC08	2.40	0.13	0.030	24.0	●		
TIP 2P24-UN IC908	2.40	0.13	0.030	24.0			●
TIP 2P20-UN IC08	2.40	0.16	0.030	20.0	●		
TIP 2P20-UN IC908	2.40	0.16	0.030	20.0			●
TIP 2P18-UN IC08	2.40	0.18	0.030	18.0	●		
TIP 2P18-UN IC908	2.40	0.18	0.030	18.0			●
TIP 2P16-UN IC08	2.40	0.20	0.030	16.0	●		
TIP 2P16-UN IC908	2.40	0.20	0.030	16.0			●
TIP 2P14-UN IC08	2.40	0.23	0.030	14.0	●		
TIP 2P14-UN IC908	2.40	0.23	0.030	14.0			●
TIP 2P13-UN IC08	2.40	0.25	0.030	13.0	●		
TIP 2P13-UN IC908	2.40	0.25	0.030	13.0			●
TIP 2P12-UN IC08	2.40	0.27	0.030	12.0	●		
TIP 2P12-UN IC908	2.40	0.27	0.030	12.0			●
TIP 4P11-UN IC908	4.00	0.30	0.030	11.0			●
TIP 4P10-UN IC808	4.00	0.33	0.050	10.0		●	
TIP 4P10-UN IC908	4.00	0.33	0.050	10.0			●
TIP 4P08-UN IC908	4.00	0.41	0.050	8.0			●

• (a) TIP inserts are 1.6 mm longer than GIP in the same pocket • Toolholder seat needs to be modified according to insert profile to ensure clearance

⁽¹⁾ Corner radius tolerance (+/-)

⁽²⁾ Threads per inch

For tools, see pages: C#-GHDR/L (301) • CGHN-D (310) • CGHN-DG (310) • CGHN-S (309) • CGPAD (308) • CGPAD-JHP (309) • GHDR/L (short pocket) (302)

• GHDR/L-JHP (short pocket) (303) • GHDR/L-JHP-MC (short pocket) (304) • GHGR/L (305) • GHMPR/L (300) • GHMR/L (300) • GHSR/L (428)

• GHSR/L-JHP-SL (429) • NQCH-GHSR/L-JHP (428)

NOTCH-GRIP
GROOVE-TURN LINE
ISCARTHREAD

UN THREADING FLTC-E
Double-Ended, Precision, Flat
Top Full Profile Threading Inserts

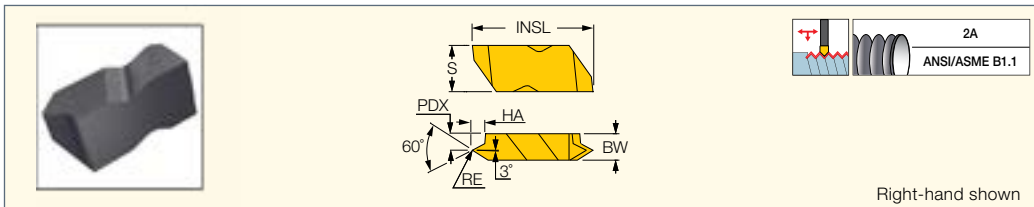

Right-hand shown

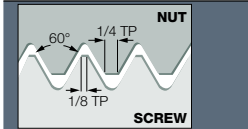

Dimensions									IC908
Designation	TPI ⁽¹⁾	RE	HA	PDX	BW	S	INSL		
FLTC-3R/L7E IC908	7.0	0.43	2.74	2.70	4.95	8.74	22.60	●	
FLTC-3R/L8E IC908	8.0	0.38	2.39	2.70	4.95	8.74	22.60	●	
FLTC-3R/L9E IC908	9.0	0.33	2.13	2.70	4.95	8.74	22.60	●	
FLTC-3R/L10E IC908	10.0	0.30	1.93	2.70	4.95	8.74	22.60	●	
FLTC-3R/L11E IC908	11.0	0.28	1.75	2.70	4.95	8.74	22.60	●	
FLTC-3R/L12E IC908	12.0	0.25	1.30	3.80	4.95	8.74	22.60	●	
FLTC-3R/L14E IC908	14.0	0.23	1.37	3.80	4.95	8.74	22.60	●	
FLTC-3R/L16E IC908	16.0	0.20	1.17	3.80	4.95	8.74	22.60	●	
FLTC-3R/L18E IC908	18.0	0.18	1.04	3.80	4.95	8.74	22.60	●	
FLTC-3R/L20E IC908	20.0	0.15	0.94	3.80	4.95	8.74	22.60	●	
FLTC-3R/L24E IC908	24.0	0.13	0.79	3.80	4.95	8.74	22.60	●	
FLTC-3R/L28E IC908	28.0	0.08	0.58	3.80	4.95	8.74	22.60	●	
FLTC-3R/L32E IC908	32.0	0.08	0.53	3.80	4.95	8.74	22.60	●	

• For internal thread limits, see pages 822-823
(1) Threads per inch

For tools, see pages: FLASR/L (807) • FLSR/L (807)

NOTCH-GRIP
GROOVE-TURN LINE
ISCARTHREAD

UN THREADING FLTC-I
Double-Ended, Precision, Flat
Top Full Profile Threading Inserts

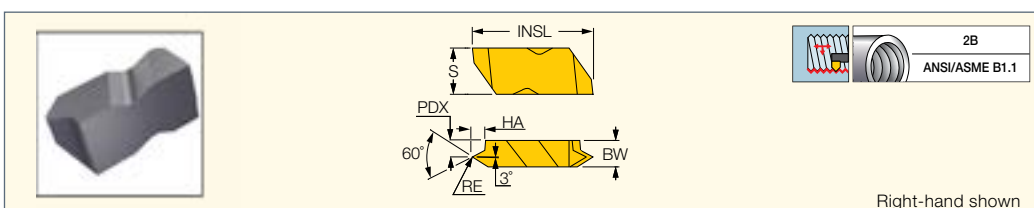

Right-hand shown

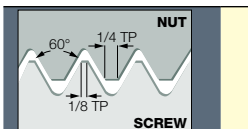

Dimensions									IC908
Designation	TPI ⁽¹⁾	RE	HA	PDX	BW	S	INSL		
FLTC-3R/L7I IC908	7.0	0.23	2.34	2.70	4.95	8.74	22.60	●	
FLTC-3R/L8I IC908	8.0	0.18	2.06	2.70	4.95	8.74	22.60	●	
FLTC-3R/L9I IC908	9.0	0.15	1.83	2.70	4.95	8.74	22.60	●	
FLTC-3R/L10I IC908	10.0	0.13	1.65	2.70	4.95	8.74	22.60	●	
FLTC-3R/L11I IC908	11.0	0.13	1.50	2.70	4.95	8.74	22.60	●	
FLTC-3R/L12I IC908	12.0	0.10	1.22	3.80	4.95	8.74	22.60	●	
FLTC-3R/L14I IC908	14.0	0.08	1.12	3.76	4.95	8.74	22.60	●	
FLTC-3R/L16I IC908	16.0	0.08	1.02	3.76	4.95	8.74	22.60	●	
FLTC-3R/L18I IC908	18.0	0.08	0.91	3.76	4.95	8.74	22.60	●	
FLTC-3R/L20I IC908	20.0	0.08	0.79	3.76	4.95	8.74	22.60	●	
FLTC-3R/L24I IC908	24.0	0.08	0.66	3.76	4.95	8.74	22.60	●	
FLTC-3R/L28I IC908	28.0	0.08	0.58	3.76	4.95	8.74	22.60	●	

• For internal thread limits, see pages 822-823
(1) Threads per inch

QUICKTHREAD

ER-W 3M-Q

External Whitworth (BSW, BSF, BSP) B.S.84-1956 DIN 259 Medium Class Full Profile Laydown Threading Inserts

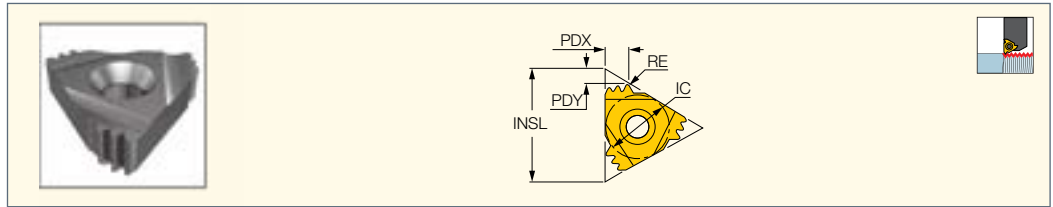

Designation	Dimensions							IC908
	IC	TPJ ⁽¹⁾	INSL	RE	PDX	PDY	CICT ⁽²⁾	
22ER 14 W 3M-Q IC908	12.70	14.0	22.00	0.23	4.30	2.60	3	●

NEW

- For Insert Identification System, see page 714 • For threading between walls use GRIP-type insert TIP-BSW • Tolerance: medium class
- For technical information and detailed cutting data, see pages 809-825

⁽¹⁾ Threads per inch

⁽²⁾ Number of teeth per corner

For tools, see pages: C#-SER/L (799) • SER-D (800) • SER/L (798)

ISCARTHREAD

ER/L-W

External Whitworth (BSW, BSF, BSP) B.S.84-1956 DIN 259 Medium Class Full Profile Laydown Threading Inserts

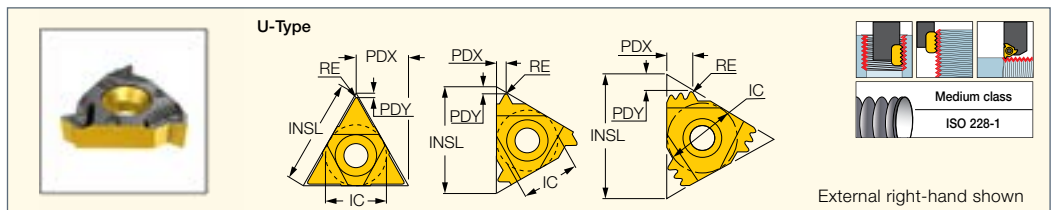

Designation	Dimensions							Tough ↔ Hard							
	IC	TPJ ⁽³⁾	INSL	RE	CICT ⁽⁴⁾	PDX	PDY	IC228	IC50M	IC250	IC08	IC508	IC808	IC908	IC1007
11ER/L 19 W IC908	6.35	19.0	11.00	0.15	1	1.00	0.80							●	
11ER 14 W IC908	6.35	14.0	11.00	0.23	1	1.00	0.70							●	
16ER 32 W IC50M	9.52	32.0	16.49	0.09	1	0.60	0.60		●						
16ER 28 W IC1007	9.52	28.0	16.49	0.11	1	0.70	0.60								●
16ER 28 W IC250	9.52	28.0	16.49	0.11	1	0.70	0.60			●					
16ER 28 W IC908	9.52	28.0	16.49	0.11	1	0.70	0.60							●	
16ER 26 W IC908	9.52	26.0	16.49	0.12	1	0.70	0.70							●	
16ER 24 W IC908	9.52	24.0	16.49	0.14	1	0.80	0.70							●	
16ER 22 W IC908	9.52	22.0	16.49	0.13	1	0.90	0.80							●	
16ER 20 W IC908	9.52	20.0	16.49	0.16	1	0.80	0.70							●	
16ER/L 19 W IC908	9.52	19.0	16.49	0.17	1	0.80	0.70							●	
16ER 19 W IC1007	9.52	19.0	16.49	0.17	1	0.80	0.70								●
16ER 19 W IC228	9.52	19.0	16.49	0.17	1	0.80	0.70	●							
16ER 19 W IC250	9.52	19.0	16.49	0.17	1	0.80	0.70			●					
16ERB 19 W IC908 ⁽¹⁾	9.52	19.0	16.49	0.17	1	0.80	0.70							●	
16ERM 19 W IC1007 ⁽¹⁾	9.52	19.0	16.49	0.16	1	1.00	0.80								●
16ERM 19 W IC250 ⁽¹⁾	9.52	19.0	16.49	0.16	1	1.00	0.80			●					
16ERM 19 W IC50M ⁽¹⁾	9.52	19.0	16.49	0.16	1	1.00	0.80		●						
16ERM 19 W IC808 ⁽¹⁾	9.52	19.0	16.49	0.16	1	1.00	0.80						●		
16ERM 19 W IC908 ⁽¹⁾	9.52	19.0	16.49	0.16	1	1.00	0.80							●	
16ER/L 18 W IC908	9.52	18.0	16.49	0.19	1	1.15	1.10							●	
16ER 18 W IC50M	9.52	18.0	16.49	0.19	1	1.15	1.10		●						
16ER 16 W IC908	9.52	16.0	16.49	0.20	1	1.20	0.90							●	
16ERB 16 W IC908 ⁽¹⁾	9.52	16.0	16.49	0.20	1	1.20	0.90							●	
16ERM 16 W IC1007	9.52	16.0	16.49	0.20	1	1.10	0.90								●
16ERM 16 W IC250 ⁽¹⁾	9.52	16.0	16.49	0.20	1	1.10	0.90			●					
16ERM 16 W IC808 ⁽¹⁾	9.52	16.0	16.49	0.20	1	1.10	0.90						●		
16ERM 16 W IC908 ⁽¹⁾	9.52	16.0	16.49	0.20	1	1.10	0.90							●	
16ER/L 14 W IC908	9.52	14.0	16.49	0.23	1	1.20	1.00							●	
16ER 14 W IC228	9.52	14.0	16.49	0.23	1	1.20	1.00	●							
16ER 14 W IC250	9.52	14.0	16.49	0.23	1	1.20	1.00			●					

- For Insert Identification System, see page 714 • For threading between walls use GRIP-type insert TIP-BSW • Tolerance: medium class
- For technical information and detailed cutting data, see pages 809-825

⁽¹⁾ With pressed chipformer

⁽²⁾ Multi-tooth

⁽³⁾ Threads per inch

⁽⁴⁾ Number of teeth per corner

For tools, see pages: C#-SER/L (799) • NQCH-SER/L-JHP (800) • SBTT#-16ER/L-JHP (418) • SER-D (800) • SER/L (798) • SER/L-JHP (799) • SER/L-JHP-MC (800)

Continued

ISCAR THREAD

ER/L-W

External Whitworth (BSW, BSF, BSP) B.S.84-1956 DIN 259 Medium Class Full Profile Laydown Threading Inserts

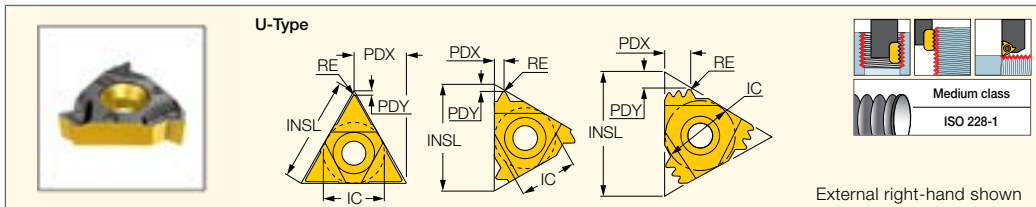

External right-hand shown

Designation	Dimensions							Tough ↔ Hard							
	IC	TP ⁽³⁾	INSL	RE	CICT ⁽⁴⁾	PDX	PDY	IC228	IC50M	IC250	IC08	IC508	IC808	IC908	IC1007
16ER 14 W 2M IC908 ⁽²⁾	9.52	14.0	16.49	0.21	2	2.70	1.70							•	
16ERB 14 W IC908 ⁽¹⁾	9.52	14.0	16.49	0.23	1	1.20	1.00							•	
16ERM 14 W IC1007 ⁽¹⁾	9.52	14.0	16.49	0.24	1	1.20	1.00								•
16ERM 14 W IC250 ⁽¹⁾	9.52	14.0	16.49	0.24	1	1.20	1.00			•					
16ERM 14 W IC50M ⁽¹⁾	9.52	14.0	16.49	0.24	1	1.20	1.00		•						
16ERM 14 W IC808 ⁽¹⁾	9.52	14.0	16.49	0.24	1	1.20	1.00					•			
16ERM 14 W IC908 ⁽¹⁾	9.52	14.0	16.49	0.24	1	1.20	1.00							•	
16ER/L 12 W IC908	9.52	12.0	16.49	0.27	1	1.40	1.20							•	
16ER/L 11 W IC250	9.52	11.0	16.49	0.29	1	1.50	1.10			•					
16ER/L 11 W IC908	9.52	11.0	16.49	0.29	1	1.50	1.10							•	
16ER 11 W IC08	9.52	11.0	16.49	0.29	1	1.50	1.10				•				
16ER 11 W IC1007	9.52	11.0	16.49	0.29	1	1.50	1.10								•
16ER 11 W IC228	9.52	11.0	16.49	0.29	1	1.50	1.10	•							
16ER 11 W IC50M	9.52	11.0	16.49	0.29	1	1.50	1.10		•						
16ER 11 W IC508	9.52	11.0	16.49	0.29	1	1.50	1.10					•			
16ERB 11 W IC908 ⁽¹⁾	9.52	11.0	16.49	0.29	1	1.50	1.10							•	
16ERM 11 W IC1007 ⁽¹⁾	9.52	11.0	16.49	0.27	1	1.50	1.10								•
16ERM 11 W IC250 ⁽¹⁾	9.52	11.0	16.49	0.27	1	1.50	1.10			•					
16ERM 11 W IC508 ⁽¹⁾	9.52	11.0	16.49	0.27	1	1.50	1.10					•			
16ERM 11 W IC808 ⁽¹⁾	9.52	11.0	16.49	0.27	1	1.50	1.10						•		
16ERM 11 W IC908 ⁽¹⁾	9.52	11.0	16.49	0.27	1	1.50	1.10							•	
16ER 10 W IC250	9.52	10.0	16.49	0.32	1	1.45	1.10			•					
16ER 10 W IC908	9.52	10.0	16.49	0.32	1	1.45	1.10								•
16ERB 10 W IC908 ⁽¹⁾	9.52	10.0	16.49	0.32	1	1.45	1.10								•
16ER 9 W IC250	9.52	9.0	16.49	0.34	1	1.70	1.20			•					
16EL 8 W IC908	9.52	8.0	16.49	0.39	1	1.50	1.20								•
16ER 8 W IC908	9.52	8.0	16.49	0.41	1	1.60	1.20								•
22ER 14 W 3M IC908 ⁽²⁾	12.70	14.0	22.00	0.21	3	4.50	2.80								•
22ER 11 W 2M IC908 ⁽²⁾	12.70	11.0	22.00	0.09	2	3.40	2.20								•
22ER 7 W IC908	12.70	7.0	22.00	0.45	1	2.30	1.60								•
22ER 6 W IC908	12.70	6.0	22.00	0.52	1	2.30	1.60								•
22ER 5 W IC250	12.70	5.0	22.00	0.65	1	2.40	1.70			•					
27ER 4 W IC908	15.88	4.0	27.50	0.85	1	2.90	2.00								•
27UEIRL 3.5 W IC908	15.88	3.5	27.50	0.95	1	13.70	2.10								•

• For Insert Identification System, see page 714 • For threading between walls use GRIP-type insert TIP-BSW • Tolerance: medium class
 • For technical information and detailed cutting data, see pages 809-825

- (1) With pressed chipformer
- (2) Multi-tooth
- (3) Threads per inch
- (4) Number of teeth per corner

For tools, see pages: C#-SER/L (799) • NQCH-SER/L-JHP (800) • SBTT#-16ER/L-JHP (418) • SER-D (800) • SER/L (798) • SER/L-JHP (799) • SER/L-JHP-MC (800)

IR/L-W

Internal Whitworth (BSW, BSF, BSP) B.S.84-1956 DIN 259 Medium Class Full Profile Laydown Threading Inserts

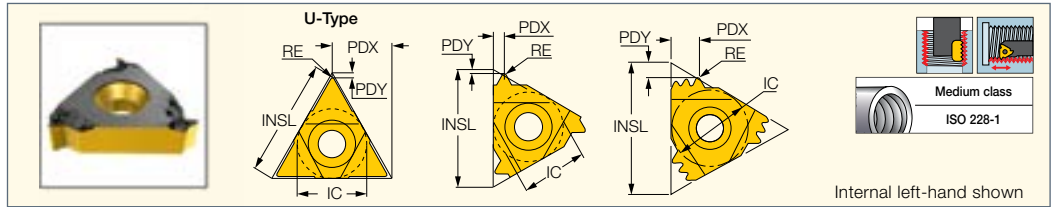

Internal left-hand shown

Designation	Dimensions							Tough ← Hard								
	IC	TPI ⁽⁴⁾	INSL	RE	PDX	PDY	CICT ⁽⁵⁾	IC228	IC928	IC50M	IC250	IC08	IC508	IC808	IC908	IC1007
06IR 26 W IC228	4.00	26.0	6.88	0.10	0.60	0.70	1	●								
08IR 28 W IC228	5.00	28.0	8.24	0.12	0.60	0.50	1	●								
08IR 19 W IC228	5.00	19.0	8.24	0.16	0.70	0.60	1	●								
08IR 19 W IC908	5.00	19.0	8.24	0.16	0.70	0.60	1								●	
08IR 19 W IC928	5.00	19.0	8.24	0.16	0.70	0.60	1		●							
08IR 18 W IC228	5.00	18.0	8.24	0.16	0.70	0.60	1	●								
08IR 16 W IC228	5.00	16.0	8.24	0.18	0.70	0.60	1	●								
11IR 36 W IC08	6.35	36.0	11.00	0.08	0.60	0.60	1					●				
11IR 28 W IC250	6.35	28.0	11.00	0.13	0.60	0.60	1				●					
11IRB 28 W IC908	6.35	28.0	11.00	0.10	0.60	0.60	1								●	
11IR 26 W IC228	6.35	26.0	11.00	0.12	0.60	0.60	1	●								
11IL 24 W IC908	6.35	24.0	11.00	0.15	0.80	0.80	1								●	
11IR 24 W IC908	6.35	24.0	11.00	0.15	0.80	0.80	1								●	
11IRB 24 W IC908	6.35	24.0	11.00	0.11	0.60	0.60	1								●	
11IR 20 W IC250	6.35	20.0	11.00	0.14	0.90	0.80	1				●					
11IR 20 W IC908	6.35	20.0	11.00	0.14	0.90	0.80	1								●	
11IRB 20 W IC908	6.35	20.0	11.00	0.14	0.90	0.80	1								●	
11IR 19 W IC1007	6.35	19.0	11.00	0.18	0.90	0.80	1									●
11IR 19 W IC250	6.35	19.0	11.00	0.18	0.90	0.80	1				●					
11IR 19 W IC908	6.35	19.0	11.00	0.18	0.90	0.80	1								●	
11IRB 19 W IC908	6.35	19.0	11.00	0.17	0.90	0.70	1								●	
11IL 18 W IC908	6.35	18.0	11.00	0.16	1.00	0.80	1								●	
11IR 18 W IC908	6.35	18.0	11.00	0.18	1.00	0.80	1								●	
11IRB 18 W IC908	6.35	18.0	11.00	0.18	1.00	0.90	1								●	
11IR 16 W IC908	6.35	16.0	11.00	0.18	1.10	0.90	1								●	
11IRB 16 W IC908	6.35	16.0	11.00	0.18	0.90	0.80	1								●	
11IL 14 W IC908	6.35	14.0	11.00	0.23	1.10	0.90	1								●	
11IR 14 W IC08	6.35	14.0	11.00	0.23	1.10	0.90	1					●				
11IR 14 W IC1007	6.35	14.0	11.00	0.23	1.10	0.90	1									●
11IR 14 W IC228	6.35	14.0	11.00	0.23	1.10	0.90	1	●								
11IR 14 W IC250	6.35	14.0	11.00	0.23	1.10	0.90	1				●					
11IR 14 W IC908	6.35	14.0	11.00	0.23	1.10	0.90	1								●	
11IRB 14 W IC908	6.35	14.0	11.00	0.23	1.00	0.90	1								●	
16IR 32 W IC50M	9.52	32.0	16.49	0.09	0.60	0.60	1			●						
16IR 28 W IC250	9.52	28.0	16.49	0.09	0.70	0.60	1				●					
16IR 26 W IC908	9.52	26.0	16.49	0.12	0.80	0.80	1								●	
16IR 24 W IC908	9.52	24.0	16.49	0.11	0.80	0.70	1								●	
16IR 22 W IC908	9.52	22.0	16.49	0.13	0.90	0.80	1								●	
16IL 20 W IC250	9.52	20.0	16.49	0.14	0.90	0.80	1				●					
16IL 20 W IC908	9.52	20.0	16.49	0.14	0.90	0.80	1								●	
16IR 20 W IC250	9.52	20.0	16.49	0.14	0.90	0.80	1				●					
16IR 20 W IC908	9.52	20.0	16.49	0.16	0.80	0.70	1								●	
16IRM 20 W IC908 (1)	9.52	20.0	16.49	0.14	0.90	0.80	1								●	
16IR 19 W IC250	9.52	19.0	16.49	0.17	0.80	0.70	1				●					
16IR 19 W IC908	9.52	19.0	16.49	0.17	0.80	0.70	1								●	
16IRB 19 W IC908 (1)	9.52	19.0	16.49	0.17	0.80	0.70	1								●	
16IRM 19 W IC250 (1)	9.52	19.0	16.49	0.15	1.00	0.80	1				●					
16IL 18 W IC908	9.52	18.0	16.49	0.18	0.80	0.80	1								●	
16IR 18 W IC908	9.52	18.0	16.49	0.18	0.80	0.80	1								●	
16IR 16 W IC908	9.52	16.0	16.49	0.20	1.00	1.00	1								●	
16IRB 16 W IC908 (1)	9.52	16.0	16.49	0.20	1.20	1.00	1								●	
16IRM 16 W IC808 (2)	9.52	16.0	16.49	0.18	1.10	0.90	1						●			
16IRM 16 W IC908 (1)	9.52	16.0	16.49	0.18	1.10	0.90	1								●	

• For Insert Identification System, see page 714 • Tolerance: medium class • For technical information and detailed cutting data, see pages 809-825

(1) With pressed chipformer

(2) With pressed chipformer.

(3) Multi-tooth

(4) Threads per inch

(5) Number of teeth per corner

For tools, see pages: AVC-D-SIR/L (805) • C#-SIR/L (803) • MGSIR/L (156) • PICIN-A-SIR/L (466) • PICIN-MGSIR/L (466) • SIR/L (801)

Continued

ISCAR THREAD

IR/L-W

Internal Whitworth (BSW, BSF, BSP) B.S.84-1956 DIN 259 Medium Class Full Profile Laydown Threading Inserts

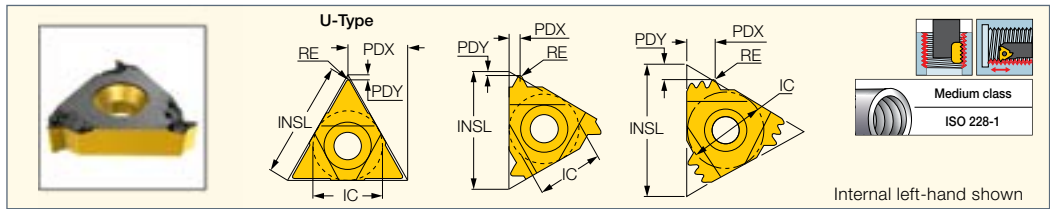

Internal left-hand shown

Designation	Dimensions							Tough ↔ Hard								
	IC	TPI ⁽⁴⁾	INSL	RE	PDX	PDY	CICT ⁽⁵⁾	IC228	IC928	IC50M	IC250	IC08	IC508	IC808	IC908	IC1007
16IL 14 W IC908	9.52	14.0	16.49	0.23	1.20	1.00	1								•	
16IR 14 W IC08	9.52	14.0	16.49	0.23	1.20	1.00	1					•				
16IR 14 W IC1007	9.52	14.0	16.49	0.23	1.20	1.00	1									•
16IR 14 W IC228	9.52	14.0	16.49	0.23	1.20	1.00	1	•								
16IR 14 W IC250	9.52	14.0	16.49	0.23	1.20	1.00	1				•					
16IR 14 W IC908	9.52	14.0	16.49	0.23	1.20	1.00	1								•	
16IR 14 W 2M IC1007	9.52	14.0	16.49	0.19	2.60	1.70	2									•
16IR 14 W 2M IC908 (3)	9.52	14.0	16.49	0.23	2.60	1.70	2								•	
16IRB 14 W IC908 (1)	9.52	14.0	16.49	0.23	1.20	1.00	1								•	
16IRM 14 W IC1007 (1)	9.52	14.0	16.49	0.21	1.20	1.00	1								•	•
16IRM 14 W IC250 (1)	9.52	14.0	16.49	0.21	1.20	1.00	1				•					
16IRM 14 W IC808 (1)	9.52	14.0	16.49	0.21	1.20	1.00	1						•			
16IRM 14 W IC908 (1)	9.52	14.0	16.49	0.21	1.20	1.00	1								•	
16IR 12 W IC908	9.52	12.0	16.49	0.27	1.50	1.20	1								•	
16IL 11 W IC908	9.52	11.0	16.49	0.29	1.50	1.10	1								•	
16IR 11 W IC08	9.52	11.0	16.49	0.29	1.50	1.10	1					•				
16IR 11 W IC1007	9.52	11.0	16.49	0.29	1.50	1.10	1									•
16IR 11 W IC228	9.52	11.0	16.49	0.29	1.50	1.10	1	•								
16IR 11 W IC250	9.52	11.0	16.49	0.29	1.50	1.10	1				•					
16IR 11 W IC50M	9.52	11.0	16.49	0.29	1.50	1.10	1			•						
16IR 11 W IC908	9.52	11.0	16.49	0.29	1.50	1.10	1								•	
16IRB 11 W IC908 (1)	9.52	11.0	16.49	0.28	1.50	1.10	1								•	
16IRM 11 W IC1007 (1)	9.52	11.0	16.49	0.27	1.50	1.10	1									•
16IRM 11 W IC250 (1)	9.52	11.0	16.49	0.27	1.50	1.10	1				•					
16IRM 11 W IC508 (1)	9.52	11.0	16.49	0.27	1.50	1.10	1					•				
16IRM 11 W IC808 (1)	9.52	11.0	16.49	0.27	1.50	1.10	1						•			
16IRM 11 W IC908 (1)	9.52	11.0	16.49	0.27	1.50	1.10	1							•		
16IR 10 W IC908	9.52	10.0	16.49	0.32	1.10	1.10	1								•	
16IRB 10 W IC908 (1)	9.52	10.0	16.49	0.31	1.50	1.10	1								•	
16IR 9 W IC250	9.52	9.0	16.49	0.34	1.70	1.20	1				•					
16IL 8 W IC50M	9.52	8.0	16.49	0.41	1.10	1.10	1			•						
16IL 8 W IC908	9.52	8.0	16.49	0.41	1.50	1.10	1								•	
16IR 8 W IC908	9.52	8.0	16.49	0.41	1.10	1.10	1								•	
22IR 14 W 3M IC908 (3)	12.70	14.0	22.00	0.21	4.50	2.80	3								•	
22IR 11 W 2M IC908 (3)	12.70	11.0	22.00	0.09	3.40	2.30	2								•	
22IR 7 W IC908	12.70	7.0	22.00	0.45	2.30	1.60	1								•	
22IR 6 W IC250	12.70	6.0	22.00	0.52	2.30	1.60	1				•					
22IR 5 W IC250	12.70	5.0	22.00	0.65	2.40	1.70	1				•					
27IR 4.5 W IC250	15.88	4.5	27.50	0.73	2.60	1.80	1				•					
27IR 4 W IC908	15.88	4.0	27.50	0.82	2.90	2.00	1								•	

• For Insert Identification System, see page 714 • Tolerance: medium class • For technical information and detailed cutting data, see pages 809-825

(1) With pressed chipformer

(2) With pressed chipformer.

(3) Multi-tooth

(4) Threads per inch

(5) Number of teeth per corner

For tools, see pages: AVC-D-SIR/L (805) • C#-SIR/L (803) • MGSIR/L (156) • PICIN-A-SIR/L (466) • PICIN-MGSIR/L (466) • SIR/L (801)

PENTA 24-W

Whitworth (BSW, BSF, BSP)
B.S.84-1956 DIN 259 Pentagonal
Full Profile External Threading
Inserts with a Chipformer

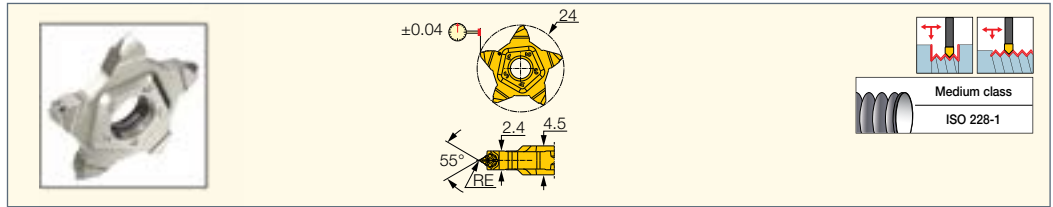

Designation	Dimensions			IC908
	TPI ⁽¹⁾	RE		
PENTA 24-28-W IC908	28.0	0.09		●
PENTA 24-19-W IC908	19.0	0.15		●
PENTA 24-14-W IC908	14.0	0.21		●

• DMIN(inch)=5.435/TPI

⁽¹⁾ Threads per inch

For tools, see pages: NQCH-PCHR/L-24-JHP (348) • PCAD RE/LE-JHP (561) • PCADR/L (353) • PCADR/L-JHP (353) • PCHBR/L (355)

• PCHR/L-24 (346) • PCHR/L-24-JHP (347) • PCHR/L-24-JHP-MC (348)

CUTGRIP

ISCARTHREAD

TIP-P-BSW

American (BSW, BSF, BSP)
Precision Ground External
Double-Ended Full Profile
Threading Inserts with a Chipformer

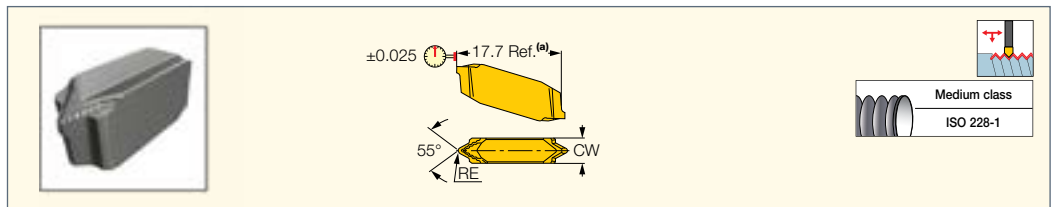

Designation	Dimensions				Tough ↔ Hard	
	CW	RE	TPI ⁽¹⁾	IC08	IC908	
TIP 2P28-BSW IC08	2.40	0.11	28.0	●		
TIP 2P28-BSW IC908	2.40	0.11	28.0		●	
TIP 2P26-BSW IC08	2.40	0.12	26.0	●		
TIP 2P26-BSW IC908	2.40	0.12	26.0		●	
TIP 2P24-BSW IC08	2.40	0.12	24.0	●		
TIP 2P24-BSW IC908	2.40	0.12	24.0		●	
TIP 2P20-BSW IC08	2.40	0.16	20.0	●		
TIP 2P20-BSW IC908	2.40	0.16	20.0		●	
TIP 2P19-BSW IC08	2.40	0.16	19.0	●		
TIP 2P19-BSW IC908	2.40	0.16	19.0		●	
TIP 2P18-BSW IC08	2.40	0.17	18.0	●		
TIP 2P18-BSW IC908	2.40	0.17	18.0		●	
TIP 2P16-BSW IC08	2.40	0.19	16.0	●		
TIP 2P16-BSW IC908	2.40	0.19	16.0		●	
TIP 2P14-BSW IC08	2.40	0.22	14.0	●		
TIP 2P14-BSW IC908	2.40	0.22	14.0		●	
TIP 4P12-BSW IC908	4.00	0.25	12.0		●	
TIP 4P11-BSW IC08	4.00	0.28	11.0	●		
TIP 4P11-BSW IC908	4.00	0.28	11.0		●	
TIP 4P10-BSW IC908	4.00	0.31	10.0		●	

• (a) TIP inserts are 1.6 mm longer than GIP in the same pocket • Toolholder seat needs to be modified according to insert profile to ensure clearance

⁽¹⁾ Threads per inch

For tools, see pages: C#-GHDR/L (301) • CGHN-D (310) • CGHN-DG (310) • CGHN-S (309) • CGPAD (308) • CGPAD-JHP (309) • GHDR/L (short pocket) (302)

• GHDR/L-JHP (short pocket) (303) • GHDR/L-JHP-MC (short pocket) (304) • GHGR/L (305) • GHMPR/L (300) • GHMR/L (300) • GHSR/L (428)

• GHSR/L-JHP-SL (429) • NQCH-GHSR/L-JHP (428)

QUICKTHREAD

ER-NPT 3M-Q

External NPT (National Pipe Threads) Full Profile Laydown Threading Inserts for Steam, Gas and Water Pipes

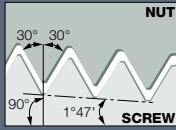
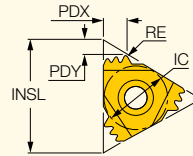

Dimensions

Designation

27ER 11.5 NPT 3M-Q IC908

IC	TPI ⁽¹⁾	INSL	RE	PDX	PDY	CICT ⁽²⁾
15.88	11.5	27.00	0.09	5.50	3.30	3

IC908

NEW

- For Insert Identification System, see page 714 • For threading between walls use GRIP-type insert TIP-NPT. • National Pipe Threads ANSI/ASME B1.20.1-1983
- For technical information and detailed cutting data, see pages 809-825

⁽¹⁾ Threads per inch

⁽²⁾ Number of teeth per corner

For tools, see page: SER/L (798)

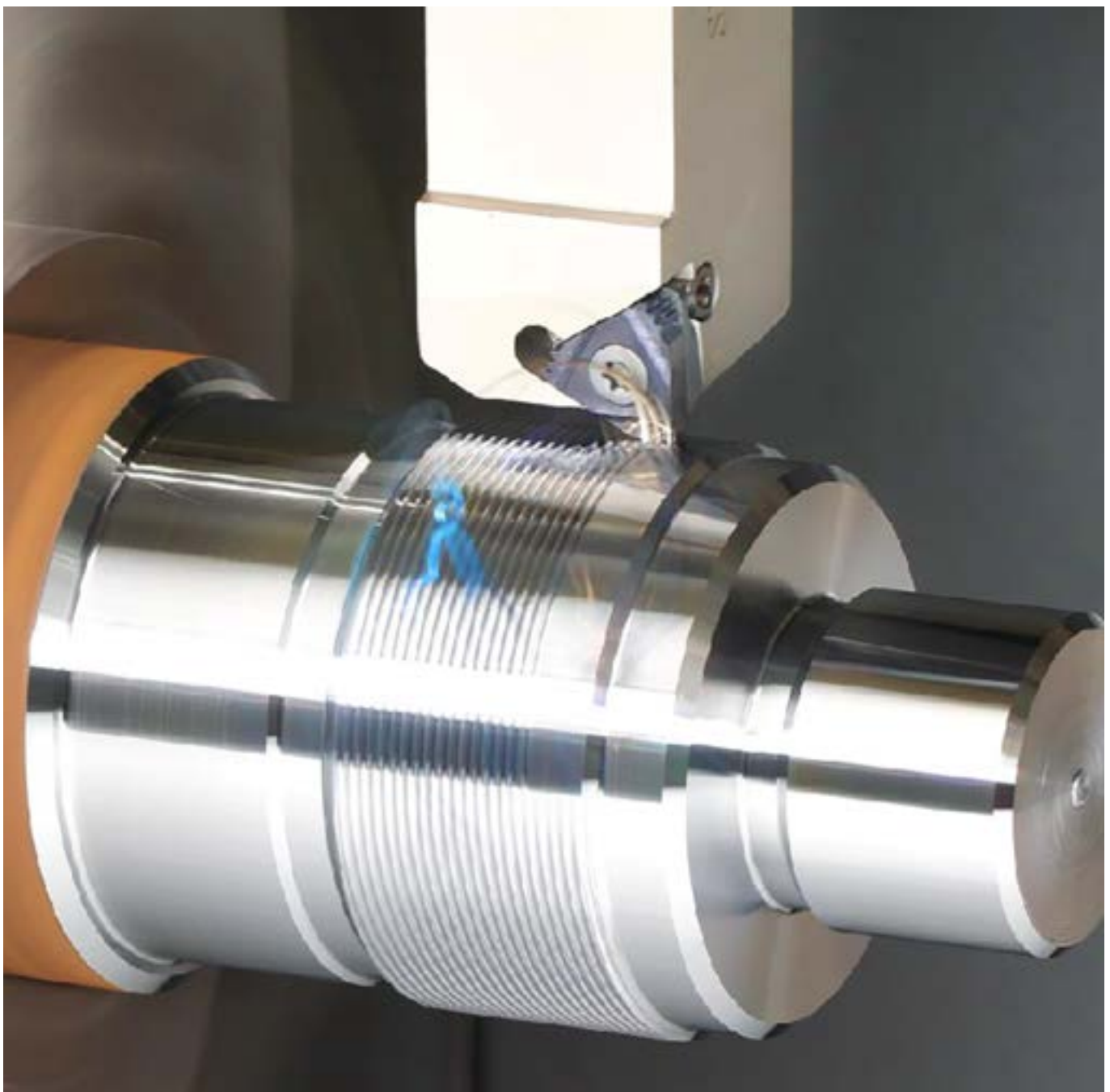

ER/L-NPT

External NPT (National Pipe Threads) Full Profile Laydown Threading Inserts for Steam, Gas, and Water Pipes

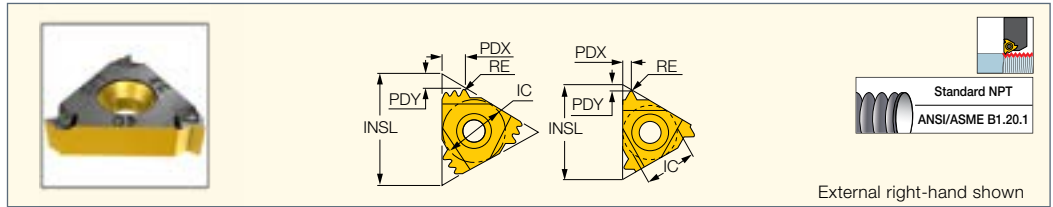

Designation	Dimensions							Tough ↔ Hard					
	IC	TPI ⁽³⁾	INSL	RE	PDX	PDY	CICT ⁽⁴⁾	IC228	IC50M	IC250	IC808	IC908	IC1007
16ER 27 NPT IC250	9.52	27.0	16.49	0.04	0.80	0.70	1			•			
16ER 27 NPT IC908	9.52	27.0	16.49	0.04	0.80	0.70	1					•	
16ER 18 NPT IC250	9.52	18.0	16.49	0.06	1.00	0.80	1			•			
16ER 18 NPT IC1007	9.52	18.0	16.49	0.06	1.10	0.90	1						•
16ER 18 NPT IC228	9.52	18.0	16.49	0.06	1.10	0.90	1	•					
16ER 18 NPT IC908	9.52	18.0	16.49	0.06	1.10	0.90	1					•	
16ERB 18 NPT IC908 ⁽¹⁾	9.52	18.0	16.49	0.06	1.10	0.90	1					•	
16ERM 18 NPT IC1007	9.52	18.0	16.49	0.05	1.00	0.80	1						•
16ERM 18 NPT IC808 ⁽¹⁾	9.52	18.0	16.49	0.05	1.00	0.80	1				•		
16ERM 18 NPT IC908 ⁽¹⁾	9.52	18.0	16.49	0.05	1.00	0.80	1					•	
16EL 14 NPT IC908	9.52	14.0	16.49	0.07	1.20	0.90	1					•	
16ER 14 NPT IC250	9.52	14.0	16.49	0.07	1.20	0.90	1			•			
16ER 14 NPT IC1007	9.52	14.0	16.49	0.07	1.20	0.90	1						•
16ER 14 NPT IC228	9.52	14.0	16.49	0.07	1.20	0.90	1	•					
16ER 14 NPT IC908	9.52	14.0	16.49	0.07	1.20	0.90	1					•	
16ERB 14 NPT IC908 ⁽¹⁾	9.52	14.0	16.49	0.07	1.20	0.90	1					•	
16ERM 14 NPT IC1007 ⁽¹⁾	9.52	14.0	16.49	0.05	1.20	0.90	1						•
16ERM 14 NPT IC250 ⁽¹⁾	9.52	14.0	16.49	0.05	1.20	0.90	1			•			
16ERM 14 NPT IC50M ⁽¹⁾	9.52	14.0	16.49	0.05	1.20	0.90	1		•				
16ERM 14 NPT IC808 ⁽¹⁾	9.52	14.0	16.49	0.05	1.20	0.90	1				•		
16ERM 14 NPT IC908 ⁽¹⁾	9.52	14.0	16.49	0.05	1.20	0.90	1					•	
16EL 11.5 NPT IC908	9.52	11.5	16.49	0.09	1.50	1.10	1					•	
16ER 11.5 NPT IC1007	9.52	11.5	16.49	0.09	1.50	1.10	1						•
16ER 11.5 NPT IC250	9.52	11.5	16.49	0.09	1.50	1.10	1			•			
16ER 11.5 NPT IC50M	9.52	11.5	16.49	0.09	1.50	1.10	1		•				
16ER 11.5 NPT IC908	9.52	11.5	16.49	0.09	1.50	1.10	1					•	
16ERB 11.5 NPT IC908 ⁽¹⁾	9.52	11.5	16.49	0.09	1.50	1.10	1					•	
16ERM 11.5 NPT IC1007 ⁽¹⁾	9.52	11.5	16.49	0.09	1.50	1.10	1						•
16ERM 11.5 NPT IC250 ⁽¹⁾	9.52	11.5	16.49	0.09	1.50	1.10	1			•			
16ERM 11.5 NPT IC808 ⁽¹⁾	9.52	11.5	16.49	0.09	1.50	1.10	1				•		
16ERM 11.5 NPT IC908 ⁽¹⁾	9.52	11.5	16.49	0.09	1.50	1.10	1					•	
16ER 8 NPT IC250	9.52	8.0	16.49	0.12	1.60	1.30	1			•			
16ER 8 NPT IC50M	9.52	8.0	16.49	0.12	1.60	1.30	1		•				
16ER 8 NPT IC908	9.52	8.0	16.49	0.12	1.60	1.30	1					•	
16ERB 8 NPT IC908 ⁽¹⁾	9.52	8.0	16.49	0.11	1.70	1.40	1					•	
16ERM 8 NPT IC1007	9.52	8.0	16.49	0.12	1.80	1.30	1						•
16ERM 8 NPT IC250 ⁽¹⁾	9.52	8.0	16.49	0.12	1.80	1.30	1			•			
16ERM 8 NPT IC808 ⁽¹⁾	9.52	8.0	16.49	0.12	1.80	1.30	1				•		
16ERM 8 NPT IC908 ⁽¹⁾	9.52	8.0	16.49	0.12	1.80	1.30	1					•	
22ER 11.5 NPT 2M IC908 ⁽²⁾	12.70	11.5	22.00	0.09	3.50	2.30	2					•	
27ER 11.5 NPT 3M IC908 ⁽²⁾	15.88	11.5	27.50	0.09	5.50	3.30	3					•	
27ER 8 NPT 2M IC908 ⁽²⁾	15.88	8.0	27.50	0.12	4.90	3.10	2					•	

• For Insert Identification System, see page 714 • For threading between walls use GRIP-type insert TIP-NPT. • National Pipe Threads ANSI/ASME B1.20.1-1983

• For technical information and detailed cutting data, see pages 809-825

⁽¹⁾ With pressed chipformer

⁽²⁾ Multi-tooth

⁽³⁾ Threads per inch

⁽⁴⁾ Number of teeth per corner

For tools, see pages: C#-SER/L (799) • NQCH-SER/L-JHP (800) • SBTT#-16ER/L-JHP (418) • SER-D (800) • SER/L (798) • SER/L-JHP (799) • SER/L-JHP-MC (800)

ISCAR THREAD

IR/L-NPT
Internal NPT (National Pipe Threads) Full Profile Laydown Threading Inserts for Steam, Gas, and Water Pipes

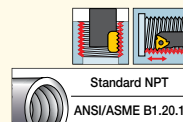
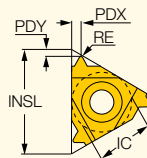

Internal left-hand shown

Designation	Dimensions							Tough ↔ Hard							
	IC	TPI ⁽³⁾	INSL	RE	PDX	PDY	CICT ⁽⁴⁾	IC228	IC50M	IC250	IC08	IC508	IC808	IC908	IC1007
06IR 27 NPT IC228	4.00	27.0	6.88	0.04	0.60	0.60	1	•							
08IR 18 NPT IC228	5.00	18.0	8.24	0.06	0.80	0.60	1	•							
08IR 18 NPT IC908	5.00	18.0	8.24	0.06	0.80	0.60	1							•	
11IL 18 NPT IC908	6.35	18.0	11.00	0.06	1.00	0.80	1							•	
11IR 18 NPT IC250	6.35	18.0	11.00	0.06	1.00	0.80	1			•					
11IR 18 NPT IC908	6.35	18.0	11.00	0.06	1.00	0.80	1							•	
11IRB 18 NPT IC908	6.35	18.0	11.00	0.06	1.00	0.80	1							•	
11IL 14 NPT IC250	6.35	14.0	11.00	0.07	1.00	0.80	1			•					
11IR 14 NPT IC1007	6.35	14.0	11.00	0.07	1.00	0.80	1								•
11IR 14 NPT IC250	6.35	14.0	11.00	0.07	1.00	0.80	1			•					
11IR 14 NPT IC908	6.35	14.0	11.00	0.07	1.00	0.80	1							•	
16IL 27 NPT IC250	9.52	27.0	16.49	0.05	0.80	0.70	1			•					
16IR 27 NPT IC908	9.52	27.0	16.49	0.05	0.80	0.70	1							•	
16IR 18 NPT IC908	9.52	18.0	16.49	0.06	1.00	0.80	1							•	
16IRM 14 NPT IC1007 (1)	9.52	14.0	16.49	0.05	1.20	0.90	1								•
16IRM 14 NPT IC250 (1)	9.52	14.0	16.49	0.05	1.20	0.90	1			•					
16IRM 14 NPT IC808 (1)	9.52	14.0	16.49	0.05	1.20	0.90	1						•		
16IRM 14 NPT IC908 (1)	9.52	14.0	16.49	0.05	1.20	0.90	1							•	
16IRB 14 NPT IC908 (1)	9.52	14.0	16.49	0.07	1.20	0.90	1							•	
16IL 14 NPT IC908	9.52	14.0	16.49	0.08	1.20	0.90	1							•	
16IR 14 NPT IC1007	9.52	14.0	16.49	0.08	1.20	0.90	1								•
16IR 14 NPT IC228	9.52	14.0	16.49	0.08	1.20	0.90	1	•							
16IR 14 NPT IC250	9.52	14.0	16.49	0.08	1.20	0.90	1			•					
16IR 14 NPT IC908	9.52	14.0	16.49	0.08	1.20	0.90	1							•	
16IRB 11.5 NPT IC908 (1)	9.52	11.5	16.49	0.09	1.50	1.10	1							•	
16IRM 11.5 NPT IC1007 (1)	9.52	11.5	16.49	0.09	1.50	1.10	1								•
16IRM 11.5 NPT IC508 (1)	9.52	11.5	16.49	0.09	1.50	1.10	1					•			
16IRM 11.5 NPT IC808 (1)	9.52	11.5	16.49	0.09	1.50	1.10	1						•		
16IRM 11.5 NPT IC908 (1)	9.52	11.5	16.49	0.09	1.50	1.10	1							•	
16IL 11.5 NPT IC250	9.52	11.5	16.49	0.09	1.50	1.10	1			•					
16IL 11.5 NPT IC908	9.52	11.5	16.49	0.09	1.50	1.10	1							•	
16IR 11.5 NPT IC1007	9.52	11.5	16.49	0.09	1.50	1.10	1								•
16IR 11.5 NPT IC50M	9.52	11.5	16.49	0.09	1.50	1.10	1		•						
16IR 11.5 NPT IC908	9.52	11.5	16.49	0.09	1.50	1.10	1							•	
16IRM 8 NPT IC1007 (1)	9.52	8.0	16.49	0.12	1.80	1.30	1								•
16IRM 8 NPT IC808 (1)	9.52	8.0	16.49	0.12	1.80	1.30	1						•		
16IRM 8 NPT IC908 (1)	9.52	8.0	16.49	0.12	1.80	1.30	1						•		
16IRB 8 NPT IC908 (1)	9.52	8.0	16.49	0.11	1.70	1.20	1							•	
16IL 8 NPT IC250	9.52	8.0	16.49	0.11	1.80	1.30	1			•					
16IL 8 NPT IC908	9.52	8.0	16.49	0.11	1.80	1.30	1							•	
16IR 8 NPT IC08	9.52	8.0	16.49	0.11	1.80	1.30	1				•				
16IR 8 NPT IC250	9.52	8.0	16.49	0.11	1.80	1.30	1			•					
16IR 8 NPT IC908	9.52	8.0	16.49	0.11	1.70	1.20	1							•	
22IR 11.5 NPT 2M IC908 (2)	12.70	11.5	22.00	0.09	3.50	2.30	2							•	
27IR 11.5 NPT 3M IC908 (2)	15.88	11.5	27.50	0.09	5.50	3.30	3							•	
27IR 8 NPT 2M IC908 (2)	15.88	8.0	27.50	0.12	5.00	3.10	2							•	

• For Insert Identification System, see page 714 • National Pipe Threads ANSI/ASME B1.20.1-1983.
 • For technical information and detailed cutting data, see pages 809-825
 (1) With pressed chipformer
 (2) Multi-tooth
 (3) Threads per inch
 (4) Number of teeth per corner
For tools, see pages: AVC-D-SIR/L (805) • C#-SIR/L (803) • MGSIR/L (156) • PICIN-A-SIR/L (466) • PICIN-MGSIR/L (466) • SIR/L (801)

PENTA 24-NPT

NPT (National Pipe Threads)
Precision Ground Pentagonal
External Full Profile Threading
Inserts with a Chipformer

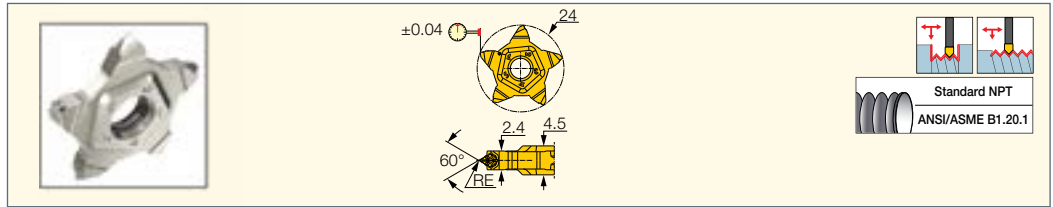

Designation	Dimensions		IC908
	TPI ⁽¹⁾	RE	
PENTA 24-18-NPT IC908	18.0	0.07	•
PENTA 24-14-NPT IC908	14.0	0.09	•

⁽¹⁾ Threads per inch

For tools, see pages: NQCH-PCHR/L-24-JHP (348) • PCAD RE/LE-JHP (561) • PCADR/L (353) • PCADR/L-JHP (353) • PCHBR/L (355)
• PCHR/L-24 (346) • PCHR/L-24-JHP (347) • PCHR/L-24-JHP-MC (348)

CUTGRIP

ISCARTHREAD

TIP-P-NPT

NPT (National Pipe Threads)
Precision Ground Double-Ended
External Full Profile Threading
Inserts with a Chipformer

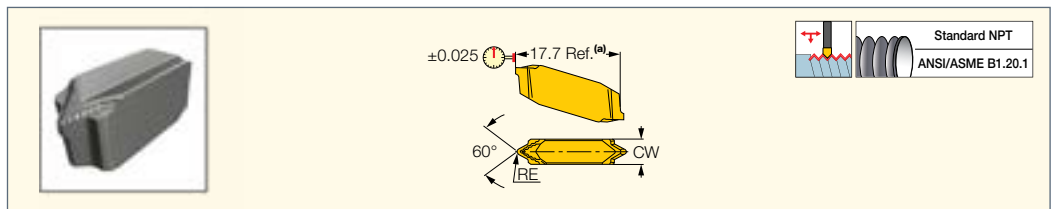

Designation	Dimensions				Tough ↔ Hard	
	CW	RE	RETOL ⁽¹⁾	TPI ⁽²⁾	IC08	IC908
TIP 2P27-NPT IC08	2.40	0.05	0.030	27.0	•	•
TIP 2P27-NPT IC908	2.40	0.05	0.030	27.0	•	•
TIP 2P18-NPT IC08	2.40	0.07	0.030	18.0	•	•
TIP 2P18-NPT IC908	2.40	0.07	0.030	18.0	•	•
TIP 2P14-NPT IC908	2.40	0.09	0.030	14.0	•	•
TIP 4P11.5-NPT IC08	4.00	0.10	0.030	11.5	•	•
TIP 4P11.5-NPT IC908	4.00	0.10	0.030	11.5	•	•
TIP 4P8-NPT IC08	4.00	0.13	0.030	8.0	•	•
TIP 4P8-NPT IC908	4.00	0.13	0.030	8.0	•	•

• (a) TIP inserts are 1.6 mm longer than GIP in the same pocket

• Toolholder seat needs to be modified according to insert profile to ensure clearance

⁽¹⁾ Corner radius tolerance (+/-)

⁽²⁾ Threads per inch

For tools, see pages: C#-GHDR/L (301) • CGHN-D (310) • CGHN-DG (310) • CGHN-S (309) • CGPAD (308) • CGPAD-JHP (309) • GHDR/L (short pocket) (302)
• GHDR/L-JHP (short pocket) (303) • GHDR/L-JHP-MC (short pocket) (304) • GHGR/L (305) • GHMPR/L (300) • GHMR/L (300) • GHSR/L (428)
• GHSR/L-JHP-SL (429) • NQCH-GHSR/L-JHP (428)

NOTCH-GRIP
GROOVE-TURN LINE
ISCARTHREAD

NPT THREADING FLDC-V-75
Double-Ended, Precision,
Flat Top Threading Inserts

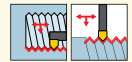
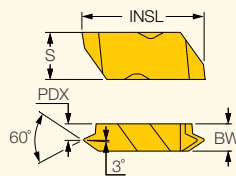

Right-hand shown

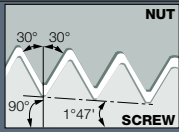

Dimensions

Designation	TPI ⁽¹⁾	IPF	PDX	BW	S	INSL	IC908
FLDC-3-8VR/L75 IC908	8.0	3/4	2.50	4.95	8.74	22.60	●
FLDC-3-115VR/L75 IC908	11.5	3/4	3.70	4.95	8.74	22.60	●
FLDC-3-14VR/L-75 IC908	14.0	3/4	3.80	4.95	8.74	22.60	●
FLDC-3-18VR/L-75 IC908	18.0	3/4	3.90	4.95	8.74	22.60	●
FLDC-3-27VR/L-75 IC908	27.0	3/4	4.10	4.95	8.74	22.60	●

• DMIN according to related boring bar • Internal & External tolerance: ANSI/ASME B1.20.1 - Standard NPT

⁽¹⁾ Threads per inch

For tools, see pages: FLASR/L (807) • FLSR/L (807)

NOTCH-GRIP
GROOVE-TURN LINE
ISCARTHREAD

NPT THREADING FLDC-NPT-E
Double-Ended, Precision, Flat
Top Multi-Tooth Threading Inserts

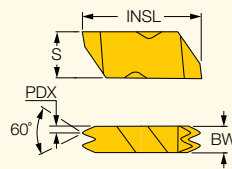

Right-hand shown

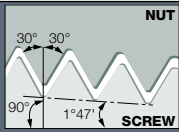

Dimensions

Designation	TPI ⁽¹⁾	IPF	PDX	BW	S	INSL	IC908
FLDC-3-8NPT 2E IC908	8.0	3/4	1.50	6.35	8.74	22.60	●
FLDC-3-11.5NPT-2E IC908	11.5	3/4	1.20	6.35	8.74	22.60	●

⁽¹⁾ Threads per inch

For tools, see pages: FLASR/L (807) • FLSR/L (807)

NOTCH-GRIP
GROOVE-TURN LINE
ISCARTHREAD

NPT THREADING FLDC-NPT-I
Double-Ended, Precision, Flat
Top Multi-Tooth Threading Inserts

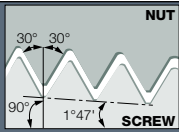
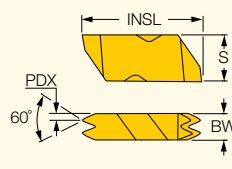

Dimensions

Designation	TPI ⁽¹⁾	IPF	PDX	BW	S	INSL	IC908
FLDC-3-8NPT 2I IC908	8.0	3/4	1.50	6.35	8.74	22.60	●
FLDC-3-11.5NPT-2I IC908	11.5	3/4	1.20	6.35	8.74	22.60	●

• For internal thread limits, see pages 822-823

⁽¹⁾ Threads per inch

ISCARTHREAD

ER-NPTF

External NPTF (National Pipe Threads) Full Profile Laydown Threading Inserts for Steam, Gas, and Water Pipes

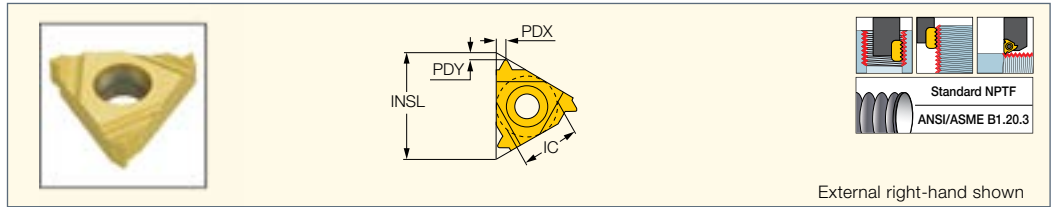

Designation	Dimensions					Tough ↔ Hard	
	IC	TPI ⁽¹⁾	INSL	PDX	PDY	IC250	IC908
11ER 14 NPTF IC908	6.35	14.0	11.00	1.00	0.73		●
16ER 27 NPTF IC908	9.52	27.0	16.49	0.60	0.55		●
16ER 18 NPTF IC908	9.52	18.0	16.49	0.90	0.80		●
16ER 14 NPTF IC250	9.52	14.0	16.49	1.20	0.90	●	
16ER 14 NPTF IC908	9.52	14.0	16.49	1.20	0.90		●
16ER 11.5 NPTF IC908	9.52	11.5	16.49	1.50	1.10		●

- For Insert Identification System, see page 714 • (National Pipe Threads-Dry Seal) ANSI/ASME B1.20.1-1976 full profile
- For technical information and detailed cutting data, see pages 809-825
- ⁽¹⁾ Threads per inch

For tools, see pages: NQCH-SER/L-JHP (800) • SER/L (798)

ISCARTHREAD

IR/L-NPTF

Internal NPTF (National Pipe Threads) Full Profile Laydown Threading Inserts for Steam, Gas, and Water Pipes

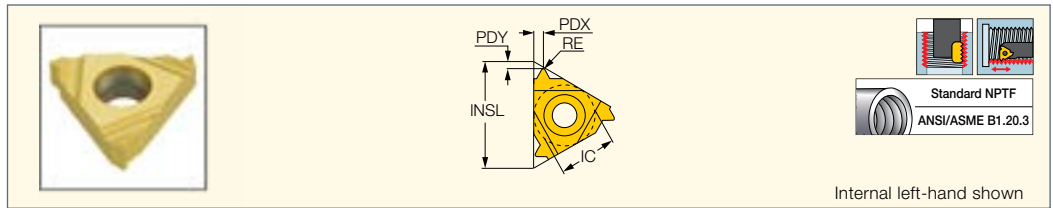

Designation	Dimensions						Tough ↔ Hard		
	IC	TPI ⁽¹⁾	INSL	RE	PDX	PDY	IC228	IC250	IC908
06IR 27 NPTF IC228	4.00	27.0	6.88	0.04	0.60	0.70	●		
08IR 27 NPTF IC228	5.00	27.0	8.24	0.04	0.60	0.60	●		
08IL 18 NPTF IC228	5.00	18.0	8.24	0.04	0.80	0.58	●		
08IR 18 NPTF IC228	5.00	18.0	8.24	0.04	0.80	0.60	●		
11IR 18 NPTF IC908	6.35	18.0	11.00	0.04	1.00	0.80			●
11IRB 18 NPTF IC908	6.35	18.0	11.00	0.04	1.00	0.80			●
11IR 14 NPTF IC908	6.35	14.0	16.49	0.04	1.10	0.80			●
16IR 18 NPTF IC908	9.52	18.0	16.49	0.06	1.00	0.80			●
16IL 14 NPTF IC908	9.52	14.0	16.49	0.07	1.20	0.90			●
16IR 14 NPTF IC250	9.52	14.0	16.49	0.07	1.20	0.90		●	
16IR 14 NPTF IC908	9.52	14.0	16.49	0.04	1.20	0.90			●
16IR 11.5 NPTF IC250	9.52	11.5	16.49	0.06	1.45	1.00		●	
16IR 11.5 NPTF IC908	9.52	11.5	16.49	0.05	1.45	1.00			●

- For Insert Identification System, see page 714 • (National Pipe Threads-Dry seal) ANSI/ASME B1.20.1-1976
 - For technical information and detailed cutting data, see pages 809-825
 - ⁽¹⁾ Threads per inch
- For tools, see pages: AVC-D-SIR/L (805) • C#-SIR/L (803) • MGSIR/L (156) • PICIN-A-SIR/L (466) • PICIN-MGSIR/L (466) • SIR/L (801)

ISCAR THREAD

ER/L-BSPT
 External BSPT (British Standard Pipe) B.S.21-1957 Full Profile Laydown Threading Inserts

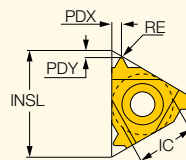

External right-hand shown

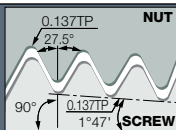

Designation	Dimensions						Tough ↔ Hard			
	IC	TPI ⁽²⁾	INSL	RE	PDX	PDY	IC250	IC808	IC908	IC1007
16ER 28 BSPT IC250	9.52	28.0	16.49	0.11	0.60	0.60	•			
16ER 28 BSPT IC908	9.52	28.0	16.49	0.11	0.60	0.60			•	
16EL 19 BSPT IC908	9.52	19.0	16.49	0.16	0.80	0.70			•	
16ER 19 BSPT IC250	9.52	19.0	16.49	0.16	0.90	0.80	•			
16ER 19 BSPT IC1007	9.52	19.0	16.49	0.16	0.80	0.70				•
16ER 19 BSPT IC908	9.52	19.0	16.49	0.16	0.80	0.70			•	
16EL 14 BSPT IC908	9.52	14.0	16.49	0.25	1.15	0.90			•	
16ER 14 BSPT IC1007	9.52	14.0	16.49	0.25	1.15	0.90				•
16ER 14 BSPT IC250	9.52	14.0	16.49	0.25	1.15	0.90	•			
16ER 14 BSPT IC908	9.52	14.0	16.49	0.25	1.15	0.90			•	
16ERB 14 BSPT IC908 ⁽¹⁾	9.52	14.0	16.49	0.23	1.15	1.00			•	
16ERM 14 BSPT IC1007 ⁽¹⁾	9.52	14.0	16.49	0.24	1.20	1.00				•
16ERM 14 BSPT IC808 ⁽¹⁾	9.52	14.0	16.49	0.24	1.20	1.00		•		
16ERM 14 BSPT IC908 ⁽¹⁾	9.52	14.0	16.49	0.24	1.20	1.00			•	
16EL 11 BSPT IC908	9.52	11.0	16.49	0.32	1.45	1.10			•	
16ER 11 BSPT IC250	9.52	11.0	16.49	0.32	1.45	1.10	•			
16ER 11 BSPT IC908	9.52	11.0	16.49	0.32	1.45	1.10			•	
16ERB 11 BSPT IC908 ⁽¹⁾	9.52	11.0	16.49	0.32	1.45	1.10			•	
16ERM 11 BSPT IC1007 ⁽¹⁾	9.52	11.0	16.49	0.31	1.50	1.10				•
16ERM 11 BSPT IC908 ⁽¹⁾	9.52	11.0	16.49	0.31	1.50	1.10			•	

- For Insert Identification System, see page 714 • For threading between walls use insert TIP-BSPT
- For technical information and detailed cutting data, see pages 809-825

⁽¹⁾ With pressed chipformer

⁽²⁾ Threads per inch

For tools, see pages: C#-SER/L (799) • NQCH-SER/L-JHP (800) • SBTT#-16ER/L-JHP (418) • SER-D (800) • SER/L (798) • SER/L-JHP (799) • SER/L-JHP-MC (800)

ISCARTHREAD

IR/L-BSPT

Internal BSPT (British Standard Pipe) B.S.21-1957 Full Profile Laydown Threading Inserts

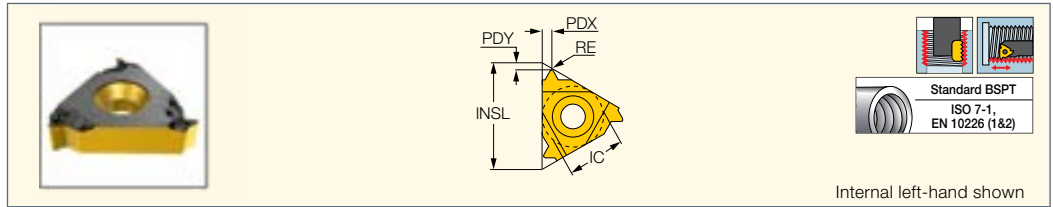

Internal left-hand shown

Designation	Dimensions						Tough ↔ Hard				
	IC	TPI ⁽²⁾	INSL	RE	PDX	PDY	IC228	IC250	IC808	IC908	IC1007
06IR 28 BSPT IC228	4.00	28.0	6.88	0.11	0.60	0.70	●				
08IR 28 BSPT IC228	5.00	28.0	8.24	0.13	0.60	0.50	●				
08IR 19 BSPT IC228	5.00	19.0	8.24	0.18	0.80	0.60	●				
11IR 19 BSPT IC250	6.35	19.0	11.00	0.16	0.90	0.80		●			
11IR 19 BSPT IC1007	6.35	19.0	11.00	0.16	0.90	0.90					●
11IR 19 BSPT IC908	6.35	19.0	11.00	0.16	0.90	0.90				●	
11IL 14 BSPT IC908	6.35	14.0	11.00	0.23	1.00	0.90				●	
11IR 14 BSPT IC908	6.35	14.0	11.00	0.23	1.00	0.90				●	
16IR 28 BSPT IC908	9.52	28.0	16.49	0.11	0.60	0.60				●	
16IR 19 BSPT IC250	9.52	19.0	16.49	0.16	0.90	0.80		●			
16IL 14 BSPT IC908	9.52	14.0	16.49	0.21	1.20	1.00				●	
16IR 14 BSPT IC908	9.52	14.0	16.49	0.23	1.20	1.00				●	
16IRB 14 BSPT IC908 ⁽¹⁾	9.52	14.0	16.49	0.23	1.20	1.00				●	
16IRM 14 BSPT IC1007 ⁽¹⁾	9.52	14.0	16.49	0.21	1.20	1.00					●
16IRM 14 BSPT IC808 ⁽¹⁾	9.52	14.0	16.49	0.21	1.20	1.00			●		
16IRM 14 BSPT IC908 ⁽¹⁾	9.52	14.0	16.49	0.21	1.20	1.00				●	
16IL 11 BSPT IC908	9.52	11.0	16.49	0.29	1.50	1.10				●	
16IR 11 BSPT IC228	9.52	11.0	16.49	0.29	1.50	1.10	●				
16IR 11 BSPT IC250	9.52	11.0	16.49	0.29	1.50	1.10		●			
16IR 11 BSPT IC908	9.52	11.0	16.49	0.29	1.50	1.10				●	
16IRB 11 BSPT IC908 ⁽¹⁾	9.52	11.0	16.49	0.29	1.50	1.10				●	
16IRM 11 BSPT IC1007 ⁽¹⁾	9.52	11.0	16.49	0.28	1.50	1.10					●
16IRM 11 BSPT IC808 ⁽¹⁾	9.52	11.0	16.49	0.28	1.50	1.10			●		
16IRM 11 BSPT IC908 ⁽¹⁾	9.52	11.0	16.49	0.28	1.50	1.10				●	

• For Insert Identification System, see page 714 • For technical information and detailed cutting data, see pages 809-825

⁽¹⁾ With pressed chipformer

⁽²⁾ Threads per inch

For tools, see pages: AVC-D-SIR/L (805) • C#-SIR/L (803) • MGSIR/L (156) • PICIN-A-SIR/L (466) • PICIN-MGSIR/L (466) • SIR/L (801)

PENTACUT

THREADING LINE

PENTA 24-BSPT

BSPT (British Standard Pipe) Precision Ground External Pentagonal Full Profile Threading Inserts with a Chipformer

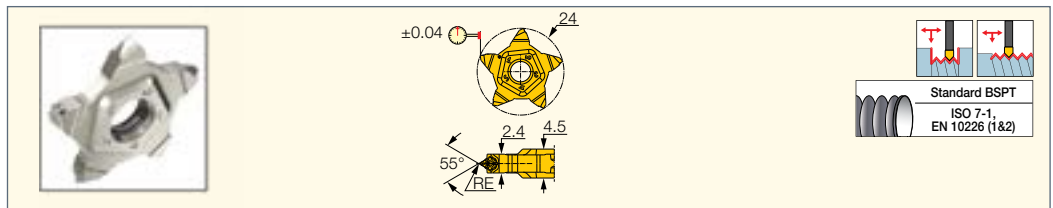

Designation	Dimensions		IC908
	TPI ⁽¹⁾	RE	
PENTA 24-19-BSPT IC908	19.0	0.16	●
PENTA 24-14-BSPT IC908	14.0	0.22	●

• DMIN(inch)=5.435/TPI

⁽¹⁾ Threads per inch

For tools, see pages: NQCH-PCHR/L-24-JHP (348) • PCAD RE/LE-JHP (561) • PCADR/L (353) • PCADR/L-JHP (353) • PCHBR/L (355)

• PCHR/L-24 (346) • PCHR/L-24-JHP (347) • PCHR/L-24-JHP-MC (348)

CUTGRIP
ISCARTHREAD

TIP-P-BSPT

Precision Ground BSPT (British Standard Pipe) External Double-Ended Full Profile Threading Inserts with a Chipformer

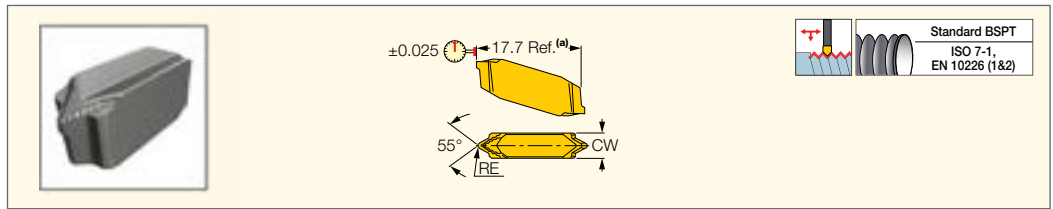

Designation	Dimensions				Tough ↔ Hard	
	CW	RE	RETOL ⁽¹⁾	TPI ⁽²⁾	IC08	IC908
TIP 2P28-BSPT IC08	2.40	0.11	0.030	28.0	●	
TIP 2P28-BSPT IC908	2.40	0.11	0.030	28.0		●
TIP 2P19-BSPT IC08	2.40	0.16	0.030	19.0	●	
TIP 2P19-BSPT IC908	2.40	0.16	0.030	19.0		●
TIP 2P14-BSPT IC08	2.40	0.22	0.030	14.0	●	
TIP 2P14-BSPT IC908	2.40	0.22	0.030	14.0		●
TIP 4P11-BSPT IC08	4.00	0.28	0.030	11.0	●	
TIP 4P11-BSPT IC908	4.00	0.28	0.030	11.0		●

• (a) TIP inserts are 1.6 mm longer than GIP in the same pocket • Toolholder seat needs to be modified according to insert profile to ensure clearance

⁽¹⁾ Corner radius tolerance (+/-)

⁽²⁾ Threads per inch

For tools, see pages: C#-GHDR/L (301) • CGHN-D (310) • CGHN-DG (310) • CGHN-S (309) • CGPAD (308) • CGPAD-JHP (309) • GHDR/L (short pocket) (302)

• GHDR/L-JHP (short pocket) (303) • GHDR/L-JHP-MC (short pocket) (304) • GHGR/L (305) • GHMPR/L (300) • GHMR/L (300) • GHSR/L (428)

• GHSLR/L-JHP-SL (429) • NQCH-GHSR/L-JHP (428)

ISCARTHREAD

ER/L-STACME

External STUB ACME Laydown Threading Inserts with a Shallow ACME Profile for Control Valves

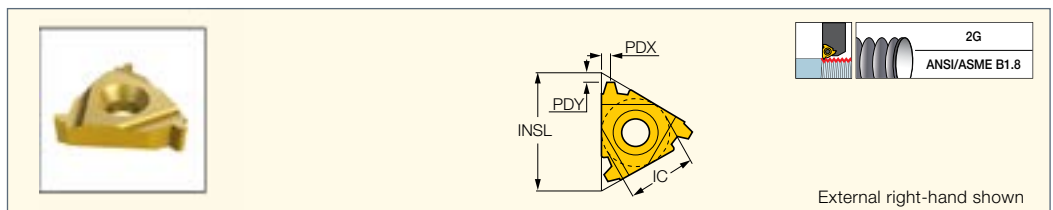

External right-hand shown

Designation	Dimensions					Tough ↔ Hard		
	IC	TPI ⁽¹⁾	INSL	PDX	PDY	IC50M	IC250	IC908
16EL 16 STACME IC250	9.52	16.0	16.49	1.00	1.00		●	
16ER 16 STACME IC908	9.52	16.0	16.49	1.00	1.00			●
16ER 14 STACME IC250	9.52	14.0	16.49	1.00	1.00		●	
16EL 12 STACME IC908	9.52	12.0	16.49	1.20	1.20			●
16ER 12 STACME IC250	9.52	12.0	16.49	1.20	1.20		●	
16ER 12 STACME IC908	9.52	12.0	16.49	1.20	1.30			●
16EL 10 STACME IC50M	9.52	10.0	16.49	1.30	1.30	●		
16ER 10 STACME IC908	9.52	10.0	16.49	1.20	1.30			●
16EL 8 STACME IC908	9.52	8.0	16.49	1.50	1.50			●
16ER 8 STACME IC250	9.52	8.0	16.49	1.50	1.50		●	
16ER 8 STACME IC50M	9.52	8.0	16.49	1.50	1.50	●		
16ER 8 STACME IC908	9.52	8.0	16.49	1.70	1.70			●
16EL 6 STACME IC908	9.52	6.0	16.49	1.80	1.80			●
16ER 6 STACME IC250	9.52	6.0	16.49	1.80	1.80		●	
16ER 6 STACME IC908	9.52	6.0	16.49	1.70	1.70			●
22EL 5 STACME IC50M	12.70	5.0	22.00	2.30	2.00	●		
22ER 5 STACME IC908	12.70	5.0	22.00	2.30	2.00			●
22ER 4 STACME IC908	12.70	4.0	22.00	2.20	2.20			●
27EL 4 STACME IC50M	15.88	4.0	27.50	2.40	2.20	●		
27ER 4 STACME IC908	15.88	4.0	27.50	2.40	2.20			●
27EL 3 STACME IC908	15.88	3.0	27.50	2.90	2.80			●
27ER 3 STACME IC250	15.88	3.0	27.50	2.90	2.80		●	

• For Insert Identification System, see page 714 • STUB ACME ASME/ANSI B1.8-1988 Class 2G • For technical information and detailed cutting data, see pages 809-825

⁽¹⁾ Threads per inch

For tools, see pages: NQCH-SER/L-JHP (800) • SER/L (798)

IR/L-STACME

Internal STUB ACME Laydown
Threading Inserts with a Shallow
ACME Profile for Control Valves

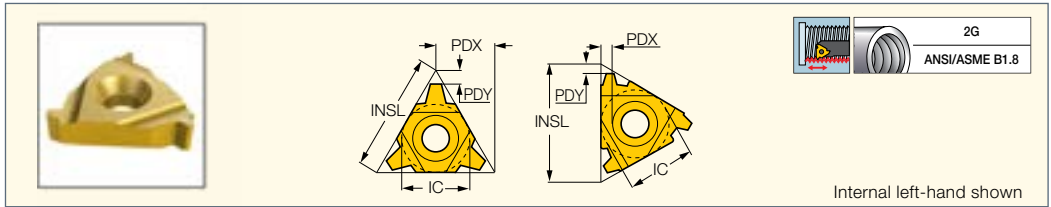

Internal left-hand shown

Designation	Dimensions					Tough ↔ Hard		
	IC	TPI ⁽¹⁾	INSL	PDX	PDY	IC50M	IC250	IC908
16IR 16 STACME IC908	9.52	16.0	16.49	1.00	1.00			●
16IR 16 STACME IC50M	9.52	16.0	16.49	1.00	1.00	●		
16IR 12 STACME IC908	9.52	12.0	16.49	1.20	1.20			●
16IR 10 STACME IC50M	9.52	10.0	16.49	1.30	1.30	●		
16IR 10 STACME IC908	9.52	10.0	16.49	1.20	1.20			●
16IL 8 STACME IC908	9.52	8.0	16.49	1.50	1.60			●
16IR 8 STACME IC50M	9.52	8.0	16.49	1.50	1.60	●		
16IR 8 STACME IC908	9.52	8.0	16.49	1.50	1.60			●
16IR 6 STACME IC250	9.52	6.0	16.49	1.80	1.80		●	
16IR 6 STACME IC908	9.52	6.0	16.49	1.70	1.60			●
22IL 5 STACME IC50M	12.70	5.0	22.00	2.30	2.00	●		
22IR 5 STACME IC50M	12.70	5.0	22.00	2.30	2.00	●		
22IR 4 STACME IC908	12.70	4.0	22.00	2.40	2.30			●
22UIRL 3 STACME IC250	12.70	3.0	22.00	11.00	3.30		●	
27IL 4 STACME IC50M	15.88	4.0	27.50	2.40	2.30	●		
27IR 4 STACME IC908	15.88	4.0	27.50	2.40	2.30			●
27IL 3 STACME IC250	15.88	3.0	27.50	2.90	2.90		●	
27IR 3 STACME IC250	15.88	3.0	27.50	2.90	2.90		●	

• For Insert Identification System, see page 714 • Tolerance: Class 2G. • For technical information and detailed cutting data, see pages 809-825

⁽¹⁾ Threads per inch

For tools, see pages: AVC-D-SIR/L (805) • C#-SIR/L (803) • SIR/L (801)

NOTCHGRIP
GROOVE-TURN LINE
ISCARTHREAD

**STUB ACME THREADING
FLAS-PT-I**

Double-Ended, Precision, Flat
Top on Internal Threading Inserts

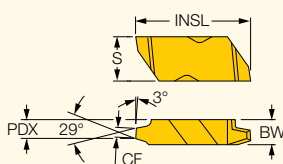

Right-hand shown

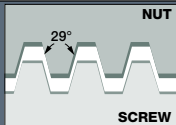

Dimensions

Designation	TPI ⁽¹⁾	CF	PDX	BW	S	INSL	IC908
FLAS-6L2-PT-I IC908	2.0	5.23	7.20	9.73	11.51	28.45	●
FLAS-4L3-PT-I IC908	3.0	3.44	5.10	6.48	11.51	28.45	●
FLAS-3L4-PT-I IC908	4.0	2.55	3.80	4.95	8.74	22.60	●
FLAS-3L5-PT-I IC908	5.0	2.01	3.80	4.95	8.74	22.60	●
FLAS-3L6-PT-I IC908	6.0	1.66	3.80	4.95	8.74	22.60	●
FLAS-3L8-PT-I IC908	8.0	1.21	3.80	4.95	8.74	22.60	●
FLAS-3L10-PT-I IC908	10.0	0.94	3.80	4.95	8.74	22.60	●
FLAS-3L12-PT-I IC908	12.0	0.83	3.80	4.95	8.74	22.60	●
FLAS-3L14-PT-I IC908	14.0	0.70	3.80	4.95	8.74	22.60	●
FLAS-3L16-PT-I IC908	16.0	0.60	3.80	4.95	8.74	22.60	●

• For internal thread limits, see pages 822-823

⁽¹⁾ Threads per inch

NOTCHGRIP
GROOVE-TURN LINE
ISCARTHREAD

**STUB ACME THREADING
FLAS-PT-E**

Double-Ended, Precision, Flat
Top External Threading Inserts

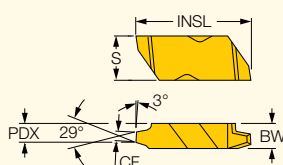

Right-hand shown

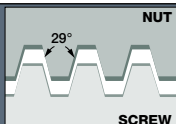

Dimensions

Designation	TPI ⁽¹⁾	CF	PDX	BW	S	INSL	IC908
FLAS-3R4-PT-E IC908	4.0	2.55	3.80	4.95	8.74	22.60	●
FLAS-3R5-PT-E IC908	5.0	2.01	3.80	4.95	8.74	22.60	●
FLAS-3R6-PT-E IC908	6.0	1.66	3.80	4.95	8.74	22.60	●
FLAS-3R8-PT-E IC908	8.0	1.21	3.80	4.95	8.74	22.60	●
FLAS-3R10-PT-E IC908	10.0	0.94	3.80	4.95	8.74	22.60	●
FLAS-3R12-PT-E IC908	12.0	0.83	3.80	4.95	8.74	22.60	●
FLAS-3R14-PT-E IC908	14.0	0.70	3.80	4.95	8.74	22.60	●
FLAS-3R16-PT-E IC908	16.0	0.60	3.80	4.95	8.74	22.60	●
FLAS-4R3-PT-E IC908	3.0	3.44	5.10	6.48	11.51	28.45	●
FLAS-6R2-PT-E IC908	2.0	5.23	7.20	9.73	11.51	28.45	●

⁽¹⁾ Threads per inch

For tools, see pages: FLASR/L (807) • FLSR/L (807)

ER/L-ACME
External ACME Profile
Laydown Threading Inserts
for Feed Screws

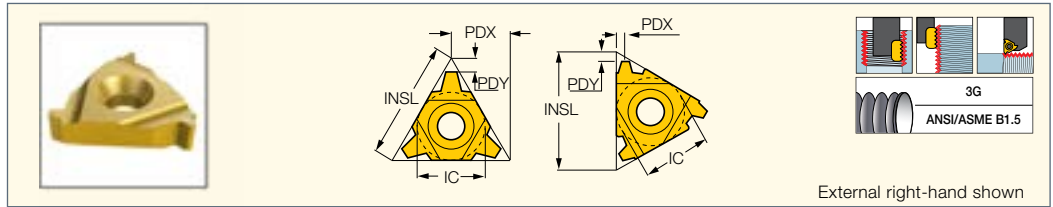

Designation	Dimensions					Tough ↔ Hard				
	IC	TPI ⁽¹⁾	INSL	PDX	PDY	IC50M	IC250	IC08	IC908	IC1007
11ER 16 ACME IC908	6.35	16.0	11.00	1.00	0.90				•	
16ER 16 ACME IC250	9.52	16.0	16.49	1.00	1.00		•			
16ER 16 ACME IC908	9.52	16.0	16.49	1.00	1.00				•	
16ER 14 ACME IC250	9.52	14.0	16.49	1.00	1.00		•			
16ER 12 ACME IC908	9.52	12.0	16.49	1.00	1.00				•	
16ER 10 ACME IC250	9.52	10.0	16.49	1.30	1.40		•			
16ER 10 ACME IC908	9.52	10.0	16.49	1.30	1.40				•	
16EL 8 ACME IC250	9.52	8.0	16.49	1.50	1.50		•			
16EL 8 ACME IC908	9.52	8.0	16.49	1.50	1.30				•	
16ER 8 ACME IC250	9.52	8.0	16.49	1.50	1.50		•			
16ER 8 ACME IC908	9.52	8.0	16.49	1.50	1.30				•	
16EL 6 ACME IC250	9.52	6.0	16.49	1.70	1.40		•			
16ER 6 ACME IC250	9.52	6.0	16.49	1.70	1.40		•			
16ER 6 ACME IC1007	9.52	6.0	16.49	1.70	1.40					•
16ER 6 ACME IC908	9.52	6.0	16.49	1.70	1.40				•	
22EL 6 ACME IC908	12.70	6.0	22.00	2.10	1.80				•	
22ER 6 ACME IC50M	12.70	6.0	22.00	2.10	1.80	•				
22ER 6 ACME IC908	12.70	6.0	22.00	2.10	1.80				•	
22EL 5 ACME IC908	12.70	5.0	22.00	2.40	2.00				•	
22ER 5 ACME IC250	12.70	5.0	22.00	2.40	2.00		•			
22ER 5 ACME IC908	12.70	5.0	22.00	2.40	2.00				•	
22EL 4 ACME IC908	12.70	4.0	22.00	2.30	2.10				•	
22ER 4 ACME IC908	12.70	4.0	22.00	2.30	2.10				•	
22UERL 4 ACME IC50M	12.70	4.0	22.00	11.00	2.30	•				
22UERL 4 ACME IC908	12.70	4.0	22.00	11.00	2.30				•	
27EL 4 ACME IC908	15.88	4.0	27.50	2.70	2.30				•	
27ER 4 ACME IC08	15.88	4.0	27.50	2.70	2.30			•		
27ER 4 ACME IC250	15.88	4.0	27.50	2.70	2.30		•			
27ER 4 ACME IC908	15.88	4.0	27.50	2.60	2.30				•	
27UERL 3 ACME IC250	15.88	3.0	27.50	13.70	2.80		•			
27UERL 3 ACME IC908	15.88	3.0	27.50	13.70	2.80				•	

• For Insert Identification System, see page 714 • ACME ASME/ANSI B1.5-1988 Class 3G

• For technical information and detailed cutting data, see pages 809-825

⁽¹⁾ Threads per inch

For tools, see pages: C#-SER/L (799) • NQCH-SER/L-JHP (800) • SBTT#-16ER/L-JHP (418) • SER-D (800) • SER/L (798) • SER/L-JHP (799) • SER/L-JHP-MC (800)

ISCAR THREAD

IR/L-ACME
Internal ACME Profile
Laydown Threading Inserts
for Feed Screws

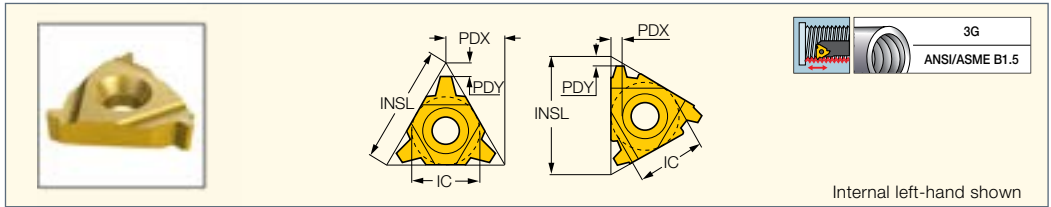

Internal left-hand shown

Designation	Dimensions					Tough ↔ Hard					
	IC	TPI ⁽²⁾	INSL	PDX	PDY	IC50M	IC250	IC08	IC508	IC908	IC1007
16IL 16 ACME IC50M	9.52	16.0	16.49	1.00	0.90	•					
16IR 16 ACME IC250	9.52	16.0	16.49	1.00	0.90		•				
16IR 16 ACME IC50M	9.52	16.0	16.49	1.00	0.90	•					
16IL 14 ACME IC50M	9.52	14.0	16.49	1.20	1.00	•					
16IL 12 ACME IC50M	9.52	12.0	16.49	1.20	1.10	•					
16IR 12 ACME IC08	9.52	12.0	16.49	1.20	1.10			•			
16IR 12 ACME IC250	9.52	12.0	16.49	1.20	1.10		•				
16IR 12 ACME IC908	9.52	12.0	16.49	1.20	1.10					•	
16IL 10 ACME IC50M	9.52	10.0	16.49	1.30	1.30	•					
16IR 10 ACME IC250	9.52	10.0	16.49	1.40	1.30		•				
16IL 8 ACME IC908	9.52	8.0	16.49	1.50	1.50					•	
16IR 8 ACME IC250	9.52	8.0	16.49	1.50	1.30		•				
16IR 8 ACME IC908	9.52	8.0	16.49	1.50	1.30					•	
16IR 6 ACME IC250 ⁽¹⁾	9.52	6.0	16.49	1.65	1.40		•				
16IR 6 ACME IC908 ⁽¹⁾	9.52	6.0	16.49	1.65	1.40					•	
16IR 6 ACME IC1007 ⁽¹⁾	9.52	6.0	16.49	1.65	1.40						•
22IL 6 ACME IC250	12.70	6.0	22.00	2.10	1.90		•				
22IL 6 ACME IC50M	12.70	6.0	22.00	2.10	1.90	•					
22IR 6 ACME IC250	12.70	6.0	22.00	2.10	1.90		•				
22IR 6 ACME IC50M	12.70	6.0	22.00	2.10	1.90	•					
22IR 6 ACME IC908	12.70	6.0	22.00	2.10	1.90					•	
22IL 5 ACME IC50M	12.70	5.0	22.00	2.10	1.80	•					
22IL 5 ACME IC508	12.70	5.0	22.00	2.10	1.80				•		
22IL 5 ACME IC908	12.70	5.0	22.00	2.10	1.80					•	
22IR 5 ACME IC250	12.70	5.0	22.00	2.30	1.80		•				
22IR 5 ACME IC908	12.70	5.0	22.00	2.10	1.80					•	
22IL 4 ACME IC250	12.70	4.0	22.00	2.10	1.95		•				
22IR 4 ACME IC908	12.70	4.0	22.00	2.10	1.95					•	
22UIRL 4 ACME IC908	12.70	4.0	22.00	11.00	2.00					•	
22UIRL 4 ACME IC08	12.70	4.0	22.00	11.00	2.00			•			
27IL 4 ACME IC908	15.88	4.0	27.50	2.60	2.30					•	
27IR 4 ACME IC250	15.88	4.0	27.50	2.60	2.30		•				
27IR 4 ACME IC908	15.88	4.0	27.50	2.60	2.30					•	
27UIRL 3 ACME IC908	15.88	3.0	27.50	13.70	2.80					•	

• For Insert Identification System, see page 714 • ACME ASME/ANSI B1.5-1988 Class 3G • For technical information and detailed cutting data, see pages 809-825

⁽¹⁾ Can be used only on special/modified holders

⁽²⁾ Threads per inch

For tools, see pages: AVC-D-SIR/L (805) • C#-SIR/L (803) • SIR/L (801)

ISCARTHREAD

ACME THREADING FLA

Double-Ended, Precision,
Flat Top Threading Inserts

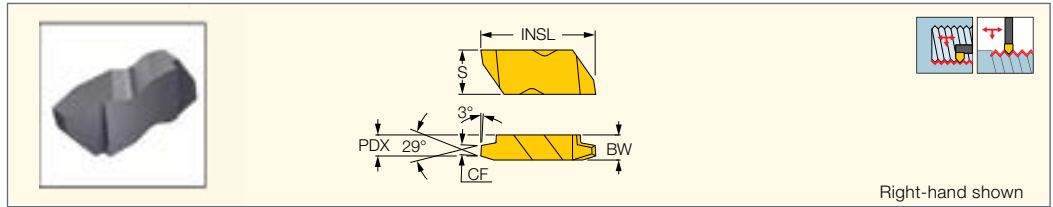

Right-hand shown

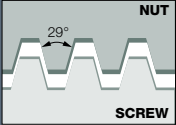
 Designation	Dimensions						IC908
	TPI ⁽¹⁾	CF	PDX	BW	S	INSL	
FLA-6R/L2 IC908	2.0	4.58	7.20	9.73	11.51	28.45	●
FLA-6R/L2.5 IC908	2.5	3.63	7.20	9.73	11.51	28.45	●
FLA-6R/L3 IC908	3.0	3.01	7.20	9.73	11.51	28.45	●
FLA-3L4 IC908	4.0	2.22	3.40	4.95	8.74	22.60	●
FLA-4R/L4 IC908	4.0	2.22	5.10	6.48	11.51	28.45	●
FLA-3R/L5 IC908	5.0	1.75	3.80	4.95	8.74	22.60	●
FLA-4L5 IC908	5.0	1.75	5.10	6.48	11.51	28.45	●
FLA-4R5 IC908	5.0	1.75	5.10	6.48	11.51	28.45	●
FLA-3L6 IC908	6.0	1.44	3.80	4.95	8.74	22.60	●
FLA-3R6 IC908	6.0	1.44	3.80	4.95	8.74	22.60	●
FLA-4L6 IC908	6.0	1.44	5.10	6.48	11.51	28.45	●
FLA-4R6 IC908	6.0	1.44	5.10	6.48	11.51	28.45	●
FLA-3L8 IC908	8.0	1.04	3.80	4.95	8.74	22.60	●
FLA-3R8 IC908	8.0	1.04	3.80	4.95	8.74	22.60	●
FLA-4L8 IC908	8.0	1.04	5.10	6.48	11.51	28.45	●
FLA-4R8 IC908	8.0	1.04	5.10	6.48	11.51	28.45	●
FLA-3R/L10 IC908	10.0	0.81	3.80	4.95	8.74	22.60	●
FLA-3R/L12 IC908	12.0	0.72	3.80	4.95	8.74	22.60	●
FLA-3R/L14 IC908	14.0	0.61	3.80	4.95	8.74	22.60	●
FLA-3R/L16 IC908	16.0	0.52	3.80	4.95	8.74	22.60	●

• Internal & External tolerance: ANSI/ASME B1.5 - 3G

⁽¹⁾ Threads per inch

For tools, see pages: FLASR/L (807) • FLSR/L (807)

NOTCHGRIP

GROOVE-TURN LINE

ISCARTHREAD

ACME THREADING FLA-PT-E

Double-Ended, Precision, Flat
Top External Threading Inserts

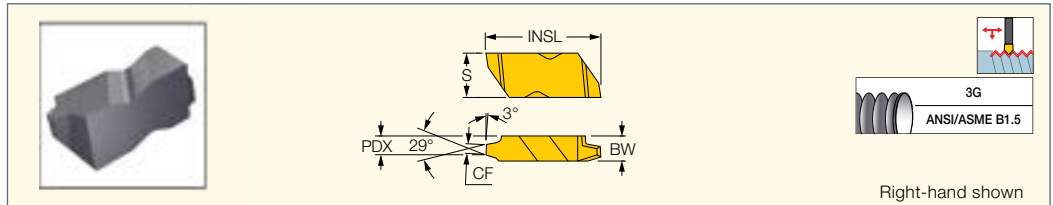

Right-hand shown

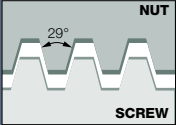
 Designation	Dimensions						IC908
	TPI ⁽¹⁾	CF	PDX	BW	S	INSL	
FLA-3R4-PT-E IC908	4.0	2.22	3.40	4.95	8.74	28.45	●
FLA-3R5-PT-E IC908	5.0	1.75	3.80	4.95	8.74	28.45	●
FLA-3R6-PT-E IC908	6.0	1.44	3.80	4.95	8.74	22.60	●
FLA-3R8-PT-E IC908	8.0	1.04	3.80	4.95	8.74	28.45	●
FLA-3R10-PT-E IC908	10.0	0.81	3.80	4.95	8.74	22.60	●
FLA-3R12-PT-E IC908	12.0	0.72	3.80	4.95	8.74	22.60	●
FLA-3R14-PT-E IC908	14.0	0.61	3.80	4.95	8.74	22.60	●
FLA-3R16-PT-E IC908	16.0	0.52	3.80	4.95	8.74	22.60	●
FLA-4R4-PT-E IC908	4.0	2.22	5.10	6.48	11.51	28.45	●
FLA-4R5-PT-E IC908	5.0	1.75	5.10	6.48	11.51	22.60	●
FLA-4R6-PT-E IC908	6.0	1.44	5.10	6.48	11.51	28.45	●
FLA-4R8-PT-E IC908	8.0	1.04	5.10	6.48	11.51	22.60	●
FLA-6R2-PT-E IC908	2.0	4.58	7.20	9.73	11.51	28.45	●
FLA-6R2.5-PT-E IC908	2.5	3.63	7.20	9.73	11.51	28.45	●
FLA-6R3-PT-E IC908	3.0	3.01	7.20	9.73	11.51	28.45	●

⁽¹⁾ Threads per inch

For tools, see pages: FLASR/L (807) • FLSR/L (807)



ACME THREADING FLA-PT-I
Double-Ended, Precision, Flat
Top Internal Threading Inserts

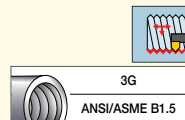
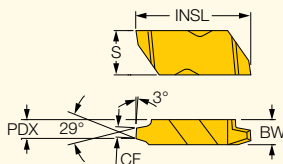

Right-hand shown

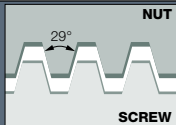

Dimensions

Designation	TPI ⁽¹⁾	CF	PDX	BW	S	INSL	IC908
FLA-3L16-PT-I IC908	16.0	0.52	3.80	4.95	8.74	22.60	●
FLA-3L14-PT-I IC908	14.0	0.61	3.80	4.95	8.74	22.60	●
FLA-3L12-PT-I IC908	12.0	0.72	3.80	4.95	8.74	22.60	●
FLA-3L10-PT-I IC908	10.0	0.81	3.80	4.95	8.74	22.60	●
FLA-3L8-PT-I IC908	8.0	1.04	3.80	4.95	8.74	22.60	●
FLA-3L6-PT-I IC908	6.0	1.44	3.80	4.95	8.74	22.60	●
FLA-3L5-PT-I IC908	5.0	1.75	3.80	4.95	8.74	22.60	●
FLA-3L4-PT-I IC908	4.0	2.22	3.40	4.95	8.74	22.60	●
FLA-4L8-PT-I IC908	8.0	1.04	5.10	6.48	11.51	28.45	●
FLA-4L6-PT-I IC908	6.0	1.44	5.10	6.48	11.51	28.45	●
FLA-4L5-PT-I IC908	5.0	1.75	5.10	6.48	11.51	28.45	●
FLA-4L4-PT-I IC908	4.0	2.22	5.10	6.48	11.51	28.45	●
FLA-6L3-PT-I IC908	3.0	3.01	7.20	9.73	11.51	28.45	●
FLA-6L2.5-PT-I IC908	2.5	3.63	7.20	9.73	11.51	28.45	●
FLA-6L2-PT-I IC908	2.0	4.58	7.20	9.73	11.51	28.45	●

• For internal thread limits, see pages 822-823

⁽¹⁾ Threads per inch



ACME THREADING FLAS
Double-Ended, Precision,
Flat Top Threading Inserts

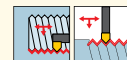
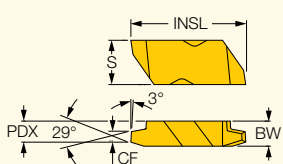

Right-hand shown

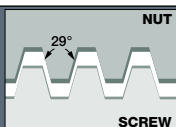

Dimensions

Designation	TPI ⁽¹⁾	CF	PDX	BW	S	INSL	IC908
FLAS-6R/L2 IC908	2.0	5.23	7.20	9.73	11.51	28.45	●
FLAS-4R/L3 IC908	3.0	3.44	5.10	6.48	11.51	28.45	●
FLAS-3L4 IC908	4.0	2.55	3.80	4.95	8.74	22.60	●
FLAS-3R/L5 IC908	5.0	2.01	3.80	4.95	8.74	22.60	●
FLAS-3R/L6 IC908	6.0	1.66	3.80	4.95	8.74	22.60	●
FLAS-3R/L8 IC908	8.0	1.21	3.80	4.95	8.74	22.60	●
FLAS-3R/L10 IC908	10.0	0.94	3.80	4.95	8.74	22.60	●
FLAS-3R/L12 IC908	12.0	0.83	3.80	4.95	8.74	22.60	●
FLAS-3R/L14 IC908	14.0	0.70	3.80	4.95	8.74	22.60	●
FLAS-3R/L16 IC908	16.0	0.60	3.80	4.95	8.74	22.60	●

• DMIN according to related boring bar • Internal & External tolerance: ANSI/ASME B1.5 - 3G

⁽¹⁾ Threads per inch

For tools, see pages: FLASR/L (807) • FLSR/L (807)

ER/L-UNJ

External UNJ Profile Laydown
Threading Inserts for the Aviation
and Aerospace Industries

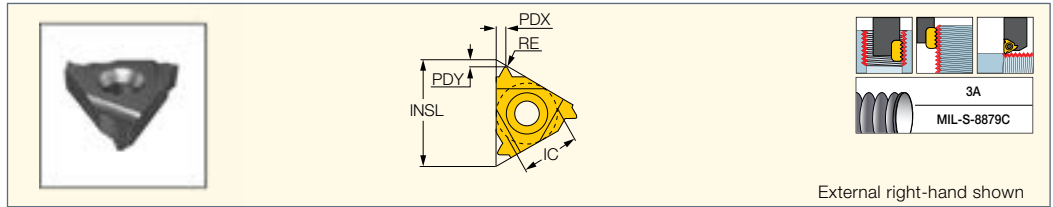

External right-hand shown

Designation	Dimensions						Tough ↔ Hard					
	IC	TPI ⁽¹⁾	INSL	RE	PDX	PDY	IC50M	IC250	IC08	IC908	IC806	IC1007
11ER 28 UNJ IC908	6.35	28.0	11.00	0.15	0.60	0.60					•	
11ER 24 UNJ IC908	6.35	24.0	11.00	0.16	0.80	0.70					•	
11ER 20 UNJ IC908	6.35	20.0	11.00	0.19	0.90	0.80					•	
11ER 18 UNJ IC908	6.35	18.0	11.00	0.23	1.00	0.80					•	
16ER 40 UNJ IC908	9.52	40.0	16.49	0.10	0.60	0.60					•	
16ER 36 UNJ IC908	9.52	36.0	16.49	0.11	0.60	0.60					•	
16ER 32 UNJ IC806	9.52	32.0	16.49	0.13	0.60	0.60						•
16ER 32 UNJ IC908	9.52	32.0	16.49	0.13	0.60	0.60					•	
16ER/L 28 UNJ IC908	9.52	28.0	16.49	0.15	0.60	0.60					•	
16ER 28 UNJ IC806	9.52	28.0	16.49	0.15	0.60	0.60						•
16EL 24 UNJ IC250	9.52	24.0	16.49	0.16	0.80	0.70		•				
16ER 24 UNJ IC806	9.52	24.0	16.49	0.18	0.80	0.70						•
16ER 24 UNJ IC908	9.52	24.0	16.49	0.18	0.80	0.70					•	
16ER/L 20 UNJ IC908	9.52	20.0	16.49	0.21	0.90	0.80					•	
16ER 20 UNJ IC1007	9.52	20.0	16.49	0.21	0.90	0.80						•
16ER 20 UNJ IC250	9.52	20.0	16.49	0.21	0.90	0.80		•				
16ER 20 UNJ IC806	9.52	20.0	16.49	0.21	0.90	0.80						•
16EL 18 UNJ IC08	9.52	18.0	16.49	0.23	0.80	0.70			•			
16ER 18 UNJ IC1007	9.52	18.0	16.49	0.23	0.80	0.70						•
16ER 18 UNJ IC806	9.52	18.0	16.49	0.23	0.80	0.70						•
16ER 18 UNJ IC908	9.52	18.0	16.49	0.23	0.80	0.70					•	
16ER/L 16 UNJ IC908	9.52	16.0	16.49	0.26	1.20	0.90					•	
16ER 16 UNJ IC1007	9.52	16.0	16.49	0.26	1.20	0.90						•
16ER 16 UNJ IC50M	9.52	16.0	16.49	0.26	1.20	0.90	•					
16ER 16 UNJ IC806	9.52	16.0	16.49	0.26	1.20	0.90						•
16ER/L 14 UNJ IC908	9.52	14.0	16.49	0.30	1.20	1.10					•	
16ER 14 UNJ IC250	9.52	14.0	16.49	0.30	1.20	1.00		•				
16ER 14 UNJ IC806	9.52	14.0	16.49	0.30	1.20	1.10						•
16ER 13 UNJ IC908	9.52	13.0	16.49	0.29	1.30	1.10					•	
16EL 12 UNJ IC908	9.52	12.0	16.49	0.35	1.20	1.10					•	
16ER 12 UNJ IC806	9.52	12.0	16.49	0.35	1.20	1.00						•
16ER 12 UNJ IC908	9.52	12.0	16.49	0.35	1.20	1.00					•	
16ER 11 UNJ IC908	9.52	11.0	16.49	0.38	1.50	1.20					•	
16ER 10 UNJ IC908	9.52	10.0	16.49	0.38	1.50	1.10					•	
16ER 10 UNJ IC806	9.52	10.0	16.49	0.38	1.50	1.10						•
16ER 9 UNJ IC250	9.52	9.0	16.49	0.47	1.45	1.15		•				
16EL 8 UNJ IC250	9.52	8.0	16.49	0.48	1.60	1.20		•				
16ER 8 UNJ IC908	9.52	8.0	16.49	0.48	1.60	1.20					•	

- UNJ MIL-S-8879C 9-1992 Class 3A • Only right-hand inserts are available in grade IC806 and IC1007
 - Thread milling application available only for inserts size 06, 08, 11
 - For Insert Identification System, see page 714 • For technical information and detailed cutting data, see pages 809-825
- ⁽¹⁾ Threads per inch

For tools, see pages: C#-SER/L (799) • NQCH-SER/L-JHP (800) • SBTT#-16ER/L-JHP (418) • SER-D (800) • SER/L (798) • SER/L-JHP (799) • SER/L-JHP-MC (800)

ISCAR THREAD

IR/L-UNJ
Internal UNJ Profile Laydown
Threading Inserts for the Aviation
and Aerospace Industries

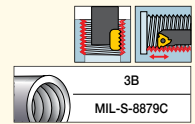
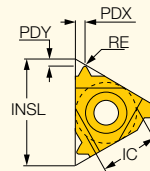

Internal left-hand shown

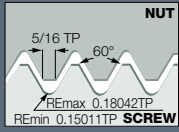

Designation	Dimensions						Tough ↔ Hard					
	IC	TPI ⁽¹⁾	INSL	RE	PDX	PDY	IC228	IC50M	IC250	IC08	IC908	IC806
08IR 20 UNJ IC228	5.00	20.0	8.24	0.09	0.65	0.57	•					
08IR 18 UNJ IC228	5.00	18.0	8.24	0.10	0.65	0.57	•					
11IR 40 UNJ IC250	6.35	40.0	11.00	0.04	0.50	0.63			•			
11IR 32 UNJ IC908	6.35	32.0	11.00	0.04	0.60	0.60					•	
11IRB 32 UNJ IC908	6.35	32.0	11.00	0.04	0.60	0.60					•	
11IR 28 UNJ IC908	6.35	28.0	11.00	0.05	0.60	0.60					•	
11IR 24 UNJ IC08	6.35	24.0	11.00	0.05	0.80	0.70				•		
11IR 24 UNJ IC908	6.35	24.0	11.00	0.05	0.80	0.70					•	
11IRB 24 UNJ IC908	6.35	24.0	11.00	0.05	0.60	0.60					•	
11IR 20 UNJ IC908	6.35	20.0	11.00	0.07	0.90	0.80					•	
11IR 18 UNJ IC806	6.35	18.0	11.00	0.08	0.90	0.80						•
11IR 18 UNJ IC908	6.35	18.0	11.00	0.08	0.90	0.80					•	
11IR 16 UNJ IC908	6.35	16.0	11.00	0.09	0.90	0.80					•	
11IR 16 UNJ IC806	6.35	16.0	11.00	0.09	0.90	0.80						•
11IRB 14 UNJ IC908	6.35	14.0	11.00	0.10	0.90	0.80					•	
16IR 32 UNJ IC908	9.52	32.0	16.49	0.04	0.40	0.60					•	
16IR 24 UNJ IC908	9.52	24.0	16.49	0.06	0.80	0.70					•	
16IR 24 UNJ IC50M	9.52	24.0	16.49	0.06	0.80	0.70		•				
16IR 20 UNJ IC908	9.52	20.0	16.49	0.07	0.80	0.80					•	
16IR 18 UNJ IC908	9.52	18.0	16.49	0.08	0.80	0.70					•	
16IR 18 UNJ IC806	9.52	18.0	16.49	0.07	0.80	0.70						•
16IR/L 16 UNJ IC908	9.52	16.0	16.49	0.09	1.20	1.00					•	
16IR 16 UNJ IC250	9.52	16.0	16.49	0.09	1.20	1.00			•			
16IR 16 UNJ IC806	9.52	16.0	16.49	0.09	1.20	1.00						•
16IR 14 UNJ IC908	9.52	14.0	16.49	0.10	1.10	1.10					•	
16IR 14 UNJ IC806	9.52	14.0	16.49	0.10	1.20	1.00						•
16IR/L 12 UNJ IC908	9.52	12.0	16.49	0.12	1.00	1.10					•	
16IR 12 UNJ IC806	9.52	12.0	16.49	0.12	1.00	1.10						•
16IR 10 UNJ IC908	9.52	10.0	16.49	0.14	1.45	1.20					•	
16IR/L 8 UNJ IC908	9.52	8.0	16.49	0.19	1.60	1.20					•	

- Thread milling application available only for inserts size 06, 08, 11
- For Insert Identification System, see page 714
- For technical information and detailed cutting data, see pages 809-825

⁽¹⁾ Threads per inch

For tools, see pages: AVC-D-SIR/L (805) • C#-SIR/L (803) • SIR/L (801)

UNJ THREADING FLJ
Double-Ended, Precision,
Flat Top Threading Inserts

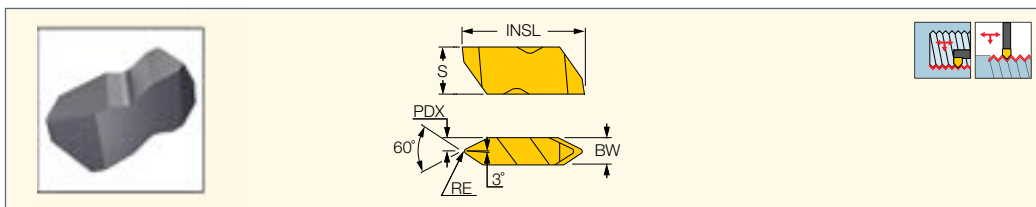

	Dimensions							IC908
	TPI ⁽¹⁾	RE	PDX	BW	S	INSL		
FLJ-3020R/L8 IC908	8.0	0.48	2.49	4.95	8.74	22.60	●	
FLJ-3014R/L12 IC908	12.0	0.32	2.49	4.95	8.74	22.60	●	
FLJ-3010R/L16 IC908	16.0	0.24	2.49	4.95	8.74	22.60	●	

• DMIN according to related boring bar • Internal tolerance: MIL-S-8879C - 3B • External tolerance: MIL-S-8879C - 3A

⁽¹⁾ Threads per inch

For tools, see pages: FLASR/L (807) • FLSR/L (807)

UNJ THREADING FLJP
Double-Ended, Precision
Threading Inserts with
a Positive Rake

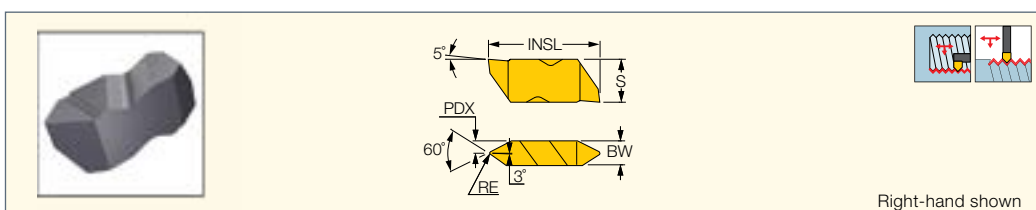

	Dimensions							IC908
	TPI ⁽¹⁾	RE	PDX	BW	S	INSL		
FLJP-3020R/L8 IC908	8.0	0.48	2.50	4.95	8.74	22.60	●	
FLJP-3014R/L12 IC908	12.0	0.32	2.50	4.95	8.74	22.60	●	
FLJP-3010R/L16 IC908	16.0	0.24	2.50	4.95	8.74	22.60	●	

• DMIN according to related boring bar • Internal tolerance: MIL-S-8879C - 3B • External tolerance: MIL-S-8879C - 3A

⁽¹⁾ Threads per inch

For tools, see pages: FLASR/L (807) • FLSR/L (807)

UNJ THREADING FLJF
Double-Ended, Precision
Flat Top Threading Inserts

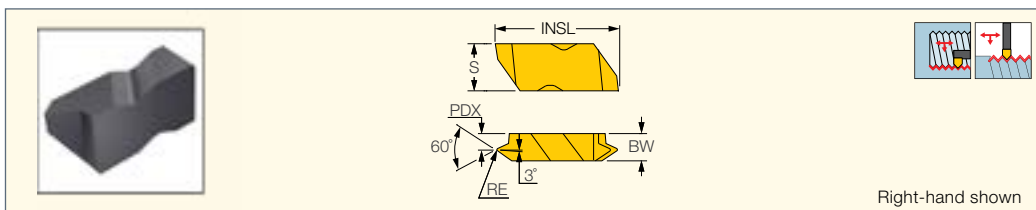

	Dimensions							IC908
	TPI ⁽¹⁾	RE	PDX	BW	S	INSL		
FLJF-3012R/L14 IC908	14.0	0.27	3.58	4.95	8.74	22.60	●	
FLJF-3010R/L16 IC908	16.0	0.24	3.60	4.95	8.74	22.60	●	
FLJF-3009R/L18 IC908	18.0	0.21	3.60	4.95	8.74	22.60	●	
FLJF-3008R/L20 IC908	20.0	0.19	3.60	4.95	8.74	22.60	●	
FLJF-3007R/L24 IC908	24.0	0.16	3.60	4.95	8.74	22.60	●	
FLJF-3006R/L28 IC908	28.0	0.14	3.60	4.95	8.74	22.60	●	
FLJF-3005R/L32 IC908	32.0	0.12	3.60	4.95	8.74	22.60	●	

• DMIN according to related boring bar • Internal tolerance: MIL-S-8879C - 3B • External tolerance: MIL-S-8879C - 3A

⁽¹⁾ Threads per inch

For tools, see pages: FLASR/L (807) • FLSR/L (807)

NOTCH-GRIP
GROOVE-TURN LINE
ISCARTHREAD

UNJ THREADING FLJK
Double-Ended, Precision
Threading Inserts with
a Positive Rake

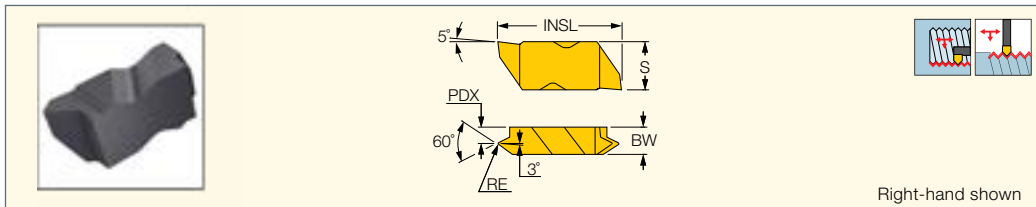

Right-hand shown

Designation	Dimensions						IC908
	TPI ⁽¹⁾	RE	PDX	BW	S	INSL	
FLJK-3012R/L14 IC908	14.0	0.27	3.58	4.95	8.74	22.60	●
FLJK-3010R/L16 IC908	16.0	0.24	3.60	4.95	8.74	22.60	●
FLJK-3009R/L18 IC908	18.0	0.21	3.60	4.95	8.74	22.60	●
FLJK-3008R/L20 IC908	20.0	0.19	3.60	4.95	8.74	22.60	●
FLJK-3007R/L24 IC908	24.0	0.16	3.60	4.95	8.74	22.60	●
FLJK-3006R/L28 IC908	28.0	0.14	3.60	4.95	8.74	22.60	●
FLJK-3005R/L32 IC908	32.0	0.12	3.60	4.95	8.74	22.60	●

• DMIN according to related boring bar • Internal tolerance: MIL-S-8879C - 3B • External tolerance: MIL-S-8879C - 3A

⁽¹⁾ Threads per inch

For tools, see pages: FLASR/L (807) • FLSR/L (807)

ISCARTHREAD

IR-MJ
Internal MJ ISO 5855 Metric
Full Profile Laydown Threading
Inserts for the Aviation and
Aerospace Industries

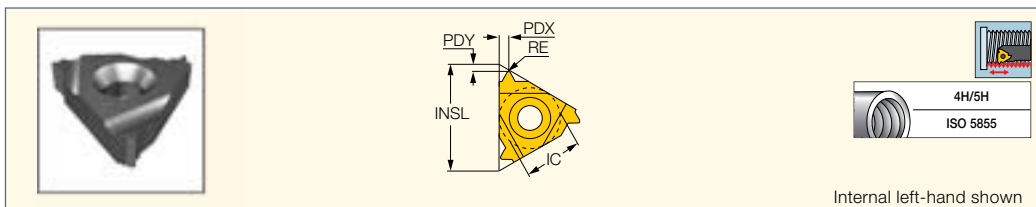

Internal left-hand shown

Designation	Dimensions						Tough ↔ Hard	
	IC	TP ⁽¹⁾	INSL	RE	PDX	PDY	IC908	IC806
11IR 1.00 MJ IC908	6.35	1.000	11.00	0.05	0.60	0.60	●	
11IR 1.00 MJ IC806	6.35	1.000	11.00	0.05	0.60	0.60		●
11IRB 1.00 MJ IC908	6.35	1.000	11.00	0.05	0.60	0.60	●	
11IR 1.25 MJ IC908	6.35	1.250	11.00	0.07	0.90	0.80	●	
11IR 1.25 MJ IC806	6.35	1.250	11.00	0.07	0.90	0.80		●
11IR 1.50 MJ IC908	6.35	1.500	11.00	0.08	1.00	0.80	●	
11IR 1.50 MJ IC806	6.35	1.500	11.00	0.08	1.00	0.80		●
11IRB 1.50 MJ IC908	6.35	1.500	11.00	0.08	0.90	0.80	●	
11IR 2.00 MJ IC908	6.35	2.000	11.00	0.12	1.00	0.90	●	
11IR 2.00 MJ IC806	6.35	2.000	11.00	0.12	1.00	0.90		●
16IR 1.00 MJ IC908	9.52	1.000	16.49	0.05	0.70	1.00	●	
16IR 1.00 MJ IC806	9.52	1.000	16.49	0.05	0.70	1.00		●
16IR 1.25 MJ IC908	9.52	1.250	16.49	0.07	0.90	0.80	●	
16IR 1.25 MJ IC806	9.52	1.250	16.49	0.07	0.90	0.80		●
16IR 1.50 MJ IC908	9.52	1.500	16.49	0.08	1.20	1.10	●	
16IR 1.50 MJ IC806	9.52	1.500	16.49	0.08	1.20	1.10		●

• Thread milling application available only for inserts size 06, 08, 11 • For Insert Identification System, see page 714

• For technical information and detailed cutting data, see pages 809-825

⁽¹⁾ Thread pitch

For tools, see pages: AVC-D-SIR/L (805) • C#-SIR/L (803) • SIR/L (801)

ER-MJ

External MJ ISO 5855 Metric Full Profile Laydown Threading Inserts for the Aviation and Aerospace Industries

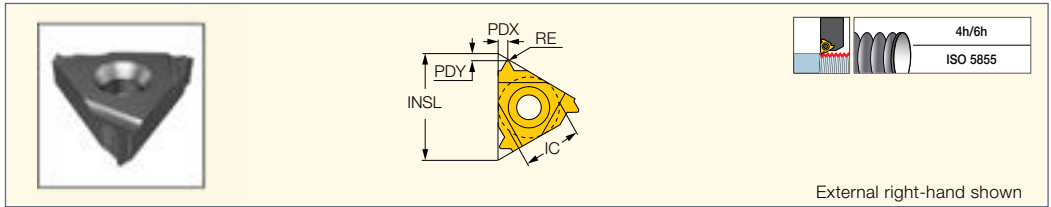

External right-hand shown

Designation	Dimensions						Tough ↔ Hard		
	IC	TP ⁽¹⁾	INSL	RE	PDX	PDY	IC250	IC908	IC806
16ER 1.00 MJ IC806	9.52	1.000	16.49	0.17	0.80	0.70			●
16ER 1.00 MJ IC908	9.52	1.000	16.49	0.17	0.80	0.70		●	
16ER 1.25 MJ IC806	9.52	1.250	16.49	0.21	0.80	0.80			●
16ER 1.25 MJ IC908	9.52	1.250	16.49	0.21	0.80	0.80		●	
16ER 1.50 MJ IC250	9.52	1.500	16.49	0.25	1.20	1.00	●		
16ER 1.50 MJ IC806	9.52	1.500	16.49	0.25	1.20	1.00			●
16ER 1.50 MJ IC908	9.52	1.500	16.49	0.25	1.20	1.00		●	
16ER 2.00 MJ IC908	9.52	2.000	16.49	0.33	1.20	1.00		●	
16ER 2.00 MJ IC806	9.52	2.000	16.49	0.33	1.20	1.00			●

• For Insert Identification System, see page 714 • For technical information and detailed cutting data, see pages 809-825

⁽¹⁾ Thread pitch

For tools, see pages: NQCH-SER/L-JHP (800) • SER/L (798)

ISCAR THREAD

ER/L-TR
External Trapezoid Shaped
DIN 103 Laydown Threading
Inserts for Feed Screws

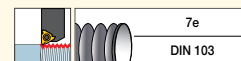
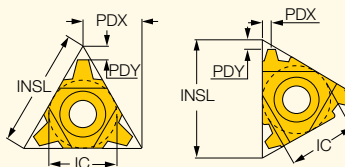

External right-hand shown

 Designation	Dimensions					Tough ↔ Hard				
	IC	TP ⁽²⁾	INSL	PDY	PDX	IC228	IC50M	IC250	IC908	IC1007
16EL 1.5 TR IC250	9.52	1.500	16.49	1.00	1.00			•		
16ER 1.5 TR IC250	9.52	1.500	16.49	1.00	1.00			•		
16ER 1.5 TR IC908	9.52	1.500	16.49	1.00	1.00				•	
16EL 2 TR IC250	9.52	2.000	16.49	1.00	1.00			•		
16ER 2 TR IC250	9.52	2.000	16.49	1.00	1.00			•		
16ER 2 TR IC908	9.52	2.000	16.49	1.00	1.00				•	
16EL 3 TR IC908	9.52	3.000	16.49	1.40	1.60				•	
16ER 3 TR IC1007	9.52	3.000	16.49	1.40	1.60					•
16ER 3 TR IC228	9.52	3.000	16.49	1.40	1.60	•				
16ER 3 TR IC250	9.52	3.000	16.49	1.40	1.60			•		
16ER 3 TR IC908	9.52	3.000	16.49	1.40	1.60				•	
16ER 4 TR IC250	9.52	4.000	16.49	1.35	1.50			•		
16ER 4 TR IC908	9.52	4.000	16.49	1.35	1.50				•	
22EL 4 TR IC908	12.70	4.000	22.00	1.80	1.90				•	
22ER 4 TR IC250	12.70	4.000	22.00	1.80	1.90			•		
22ER 4 TR IC908	12.70	4.000	22.00	1.80	1.90				•	
22EL 5 TR IC250	12.70	5.000	22.00	2.00	2.40			•		
22EL 5 TR IC908	12.70	5.000	22.00	2.00	2.40				•	
22ER 5 TR IC250	12.70	5.000	22.00	2.00	2.40			•		
22ER 5 TR IC50M	12.70	5.000	22.00	2.00	2.40		•			
22ER 5 TR IC908	12.70	5.000	22.00	2.00	2.40				•	
22EL 6 TR IC908	12.70	6.000	22.00	2.00	2.40				•	
22ER 6 TR IC908	12.70	6.000	22.00	2.00	2.40				•	
22UERL 6 TR IC250	12.70	6.000	22.00	2.00	11.00			•		
22UERL 6 TR IC50M	12.70	6.000	22.00	2.00	11.00		•			
22UERL 6 TR IC908	12.70	6.000	22.00	2.00	11.00				•	
22UERL 7 TR IC250	12.70	7.000	22.00	2.30	11.00			•		
22UERL 8 TR IC250	12.70	8.000	22.00	2.30	11.00			•		
27EL 6 TR IC908	15.88	6.000	27.50	2.30	2.60				•	
27ER 6 TR IC250	15.88	6.000	27.50	2.30	2.70			•		
27ER 6 TR IC908	15.88	6.000	27.50	2.30	2.60				•	
27EL 7 TR IC250	15.88	7.000	27.50	2.20	2.70			•		
27ER 7 TR IC250	15.88	7.000	27.50	2.20	2.70			•		
27ER 7 TR IC908	15.88	7.000	27.50	2.20	2.70				•	
27UERL 8 TR IC250	15.88	8.000	27.50	2.68	13.75			•		
27UERL 8 TR IC908	15.88	8.000	27.50	2.68	13.75				•	
27UERL 9 TR IC250	15.88	9.000	27.50	3.00	13.70			•		
27UERL 9 TR IC908	15.88	9.000	27.50	3.00	13.70				•	
27UERL 10 TR IC250 ⁽¹⁾	15.88	10.000	27.50	3.00	13.70			•		
27UERL 10 TR IC908 ⁽¹⁾	15.88	10.000	27.50	3.00	13.70				•	

• For Insert Identification System, see page 714 • DIN 103 04/1977,1502901/1977 Class 7e • For technical information and detailed cutting data, see pages 809-825

⁽¹⁾ One cutting edge only. Special anvil required.

⁽²⁾ Thread pitch

For tools, see pages: NQCH-SER/L-JHP (800) • SER/L (798)

IR/L-TR

Internal Trapezoid Shaped
DIN 103 Laydown Threading
Inserts for Feed Screws

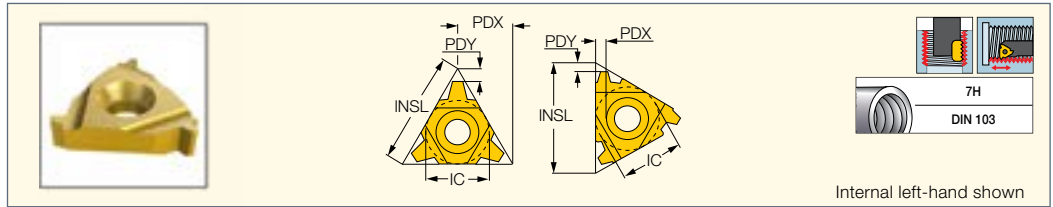

Internal left-hand shown

Designation	Dimensions					Tough ↔ Hard			
	IC	INSL	TP ⁽²⁾	PDX	PDY	IC228	IC50M	IC250	IC908
08IR 1.5 TR IC228 ⁽¹⁾	5.00	8.24	1.500	0.60	0.60	•			
08UIRL 2 TR IC228	5.00	8.66	2.000	4.33	0.90	•			
16IL 2 TR IC250	9.52	16.49	2.000	1.30	1.00			•	
16IL 2 TR IC908	9.52	16.49	2.000	1.30	1.00				•
16IL 3 TR IC908	9.52	16.49	3.000	1.50	1.30				•
16IR 1.5 TR IC250	9.52	16.49	1.500	1.00	1.00			•	
16IR 1.5 TR IC908	9.52	16.49	1.500	1.10	1.00				•
16IR 2 TR IC250	9.52	16.49	2.000	1.30	1.00			•	
16IR 2 TR IC908	9.52	16.49	2.000	1.10	1.00				•
16IR 3 TR IC228	9.52	16.49	3.000	1.50	1.30	•			
16IR 3 TR IC908	9.52	16.49	3.000	1.50	1.30				•
22IL 4 TR IC908	12.70	22.00	4.000	2.00	1.90				•
22IL 5 TR IC908	12.70	22.00	5.000	2.10	1.90				•
22IL 6 TR IC908	12.70	22.00	6.000	2.10	1.80				•
22IR 4 TR IC250	12.70	22.00	4.000	2.00	1.90			•	
22IR 4 TR IC908	12.70	22.00	4.000	2.00	1.90				•
22IR 5 TR IC250	12.70	22.00	5.000	2.10	1.90			•	
22IR 5 TR IC908	12.70	22.00	5.000	2.10	1.90				•
22IR 6 TR IC250	12.70	22.00	6.000	2.10	1.80			•	
22IR 6 TR IC50M	12.70	22.00	6.000	2.10	1.80		•		
22IR 6 TR IC908	12.70	22.00	6.000	2.10	1.80				•
22UIRL 6 TR IC250	12.70	22.00	6.000	11.00	2.00			•	
22UIRL 6 TR IC908	12.70	22.00	6.000	11.00	2.00				•
22UIRL 7 TR IC250	12.70	22.00	7.000	11.00	2.30			•	
27IL 6 TR IC908	15.88	27.50	6.000	2.70	2.30				•
27IR 6 TR IC250	15.88	27.50	6.000	2.70	2.30			•	
27IR 6 TR IC908	15.88	27.50	6.000	2.60	2.30				•
27IR 7 TR IC250	15.88	27.50	7.000	2.60	2.20			•	
27UIRL 10 TR IC908 ⁽¹⁾	15.88	27.50	10.000	13.75	2.96				•
27UIRL 8 TR IC228	15.88	27.50	8.000	13.70	2.50	•			
27UIRL 8 TR IC250	15.88	27.50	8.000	13.70	2.50			•	
27UIRL 8 TR IC908	15.88	27.50	8.000	13.75	2.90				•
27UIRL 9 TR IC250	15.88	27.50	9.000	13.70	3.00			•	
27UIRL 9 TR IC908	15.88	27.50	9.000	13.70	3.00				•

• For Insert Identification System, see page 714 • Tolerance: Class 7H • For technical information and detailed cutting data, see pages 809-825

⁽¹⁾ A single threading corner

⁽²⁾ Thread pitch

For tools, see pages: AVC-D-SIR/L (805) • C#-SIR/L (803) • SIR/L (801)

ISCAR THREAD

ER-PG

External Threading Inserts
for the Electric Industry

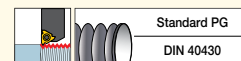
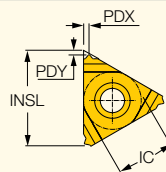

External right-hand shown

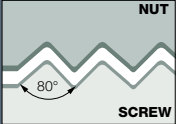
 Designation	Dimensions						Tough ↔ Hard	
	IC	TPI ⁽¹⁾	INSL	RE	PDX	PDY	IC08	IC908
16ER 20 PG IC908	9.52	20.0	16.49	0.13	0.80	0.70		●
16ER 18 PG IC08	9.52	18.0	16.49	0.15	0.90	0.80	●	
16ER 18 PG IC908	9.52	18.0	16.49	0.15	0.90	0.80		●
16ER 16 PG IC908	9.52	16.0	16.49	0.17	1.00	0.80		●

• For Insert Identification System, see page 714

⁽¹⁾ Threads per inch

For tools, see pages: NQCH-SER/L-JHP (800) • SER/L (798)

ISCAR THREAD

IR/L-PG

Internal Thread Profile Inserts
for the Electric Industry

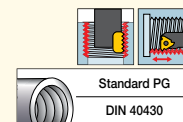
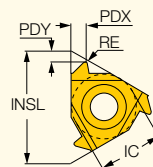

Internal left-hand shown

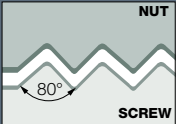
 Designation	Dimensions						Tough ↔ Hard	
	IC	TPI ⁽¹⁾	INSL	RE	PDX	PDY	IC228	IC908
08IR 20 PG IC228	5.00	20.0	8.24	0.14	0.70	0.55	●	
11IR 18 PG IC908	6.35	18.0	11.00	0.15	0.90	0.80		●
16IR 18 PG IC908	9.52	18.0	16.49	0.15	0.90	0.80		●
16IR 16 PG IC908	9.52	16.0	16.49	0.17	0.90	0.70		●

• For Insert Identification System, see page 714

⁽¹⁾ Threads per inch

For tools, see pages: AVC-D-SIR/L (805) • C#-SIR/L (803) • SIR/L (801)

ISCARTHREAD

ER/L-SAGE

External Buttress Thread
(DIN 513) for High Force in
One Direction Applications

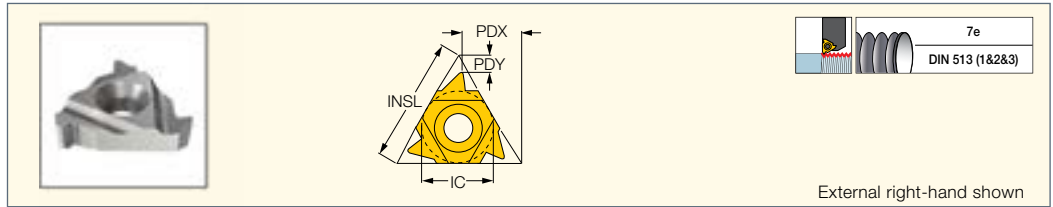

External right-hand shown

Designation	Dimensions					Tough ↔ Hard	
	IC	TP ⁽²⁾	INSL	PDX	PDY	IC250	IC908
16EL 2 SAGE IC908	9.52	2.000	16.49	1.60	1.10		●
16ER 2 SAGE IC908	9.52	2.000	16.49	1.60	1.10		●
22ER 3 SAGE IC908	12.70	3.000	22.00	2.40	1.50		●
22EL 4 SAGE IC908	12.70	4.000	22.00	3.10	1.90		●
22ER 4 SAGE IC250	12.70	4.000	22.00	3.10	1.90	●	
22UER 5 SAGE IC908 ⁽¹⁾	12.70	5.000	22.00	11.60	1.20		●
22UEL 6 SAGE IC908 ⁽¹⁾	12.70	6.000	22.00	11.70	1.20		●
22UER 6 SAGE IC908 ⁽¹⁾	12.70	6.000	22.00	11.70	1.20		●

• For Insert Identification System, see page 714 • For technical information and detailed cutting data, see pages 809-825

⁽¹⁾ Requires special anvil

⁽²⁾ Thread pitch

For tools, see pages: SER/L (798) • SER-D (800) • SER/L-JHP (799) • SER/L-JHP-MC (800) • C#-SER/L (799) • NQCH-SER/L-JHP (800)

• SBTT#-16ER/L-JHP (418)

ISCARTHREAD

IR/L-SAGE

Internal Sagengengewinde
(DIN 513) Thread Application
for High Force in One
Direction Application

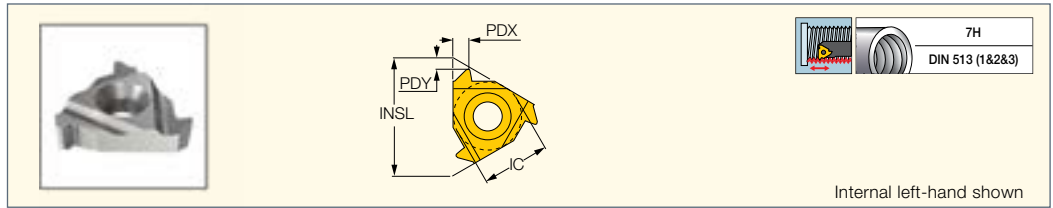

Internal left-hand shown

Designation	Dimensions					IC908
	IC	INSL	TP ⁽²⁾	PDX	PDY	
16IL 2 SAGE IC908	9.52	16.49	2.000	1.70	1.20	●
16IR 2 SAGE IC908	9.52	16.49	2.000	1.70	1.20	●
22IR 3 SAGE IC908	12.70	22.00	3.000	2.90	1.90	●
22IR 4 SAGE IC908	12.70	22.00	4.000	3.30	2.20	●
22UIR 5 SAGE IC908	12.70	22.00	5.000	11.70	1.90	●
22UIR 6 SAGE IC908 ⁽¹⁾	12.70	22.00	6.000	11.90	2.10	●

• For Insert Identification System, see page 714 • For technical information and detailed cutting data, see pages 809-825

⁽¹⁾ Requires special anvil

⁽²⁾ Thread pitch

For tools, see pages: AVC-D-SIR/L (805) • C#-SIR/L (803) • SIR/L (801)

ISCAR THREAD

ER/L-ABUT

External American Buttress Laydown Threading Inserts for High Force Transmission in One Direction

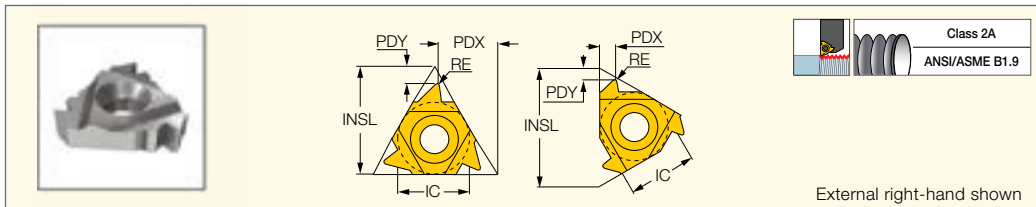

External right-hand shown

Designation	Dimensions						Tough ↔ Hard	
	IC	TPI ⁽¹⁾	INSL	RE	PDX	PDY	IC250	IC908
16ER 20 ABUT IC908	9.52	20.0	16.49	0.07	1.30	1.00		●
16EL 16 ABUT IC908	9.52	16.0	16.49	0.09	1.50	1.10		●
16ER 16 ABUT IC250	9.52	16.0	16.49	0.09	1.50	1.30	●	
16ER 16 ABUT IC908	9.52	16.0	16.49	0.09	1.50	1.10		●
16EL 12 ABUT IC908	9.52	12.0	16.49	0.12	2.00	1.40		●
16ER 12 ABUT IC250	9.52	12.0	16.49	0.12	2.00	1.40	●	
16ER 12 ABUT IC908	9.52	12.0	16.49	0.12	2.00	1.40		●
16EL 10 ABUT IC908	9.52	10.0	16.49	0.15	2.30	1.50		●
16ER 10 ABUT IC908	9.52	10.0	16.49	0.15	2.30	1.50		●
22ER 8 ABUT IC250	12.70	8.0	22.00	0.18	3.30	2.10	●	
22ER 8 ABUT IC908	12.70	8.0	22.00	0.18	3.30	2.10		●
22ER 6 ABUT IC908	12.70	6.0	22.00	0.25	3.40	2.10		●
22UER 4 ABUT IC250	12.70	4.0	22.00	0.41	9.80	2.30	●	
22UER 4 ABUT IC908	12.70	4.0	22.00	0.41	9.50	2.30		●
27UEL 3 ABUT IC908	15.88	3.0	27.50	0.45	12.30	2.60		●
27UER 3 ABUT IC250	15.88	3.0	27.50	0.45	12.30	2.60	●	
27UER 3 ABUT IC908	15.88	3.0	27.50	0.45	12.30	2.60		●

• For Insert Identification System, see page 714 • ANSI B1.9-1973 Class 2 • For technical information and detailed cutting data, see pages 809-825

⁽¹⁾ Threads per inch

For tools, see pages: NQCH-SER/L-JHP (800) • SER/L (798)

ISCAR THREAD

IR/L-ABUT

Internal American Buttress Laydown Threading Inserts for High Force Transmission in One Direction

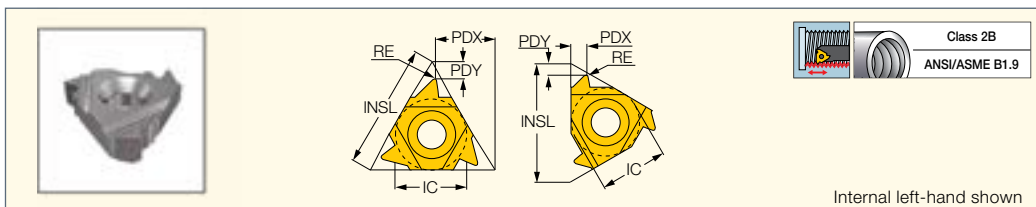

Internal left-hand shown

Designation	Dimensions						Tough ↔ Hard		
	IC	TPI ⁽¹⁾	INSL	RE	PDX	PDY	IC50M	IC250	IC908
11IR 20 ABUT IC908	6.35	20.0	11.00	0.07	1.20	0.85			●
11IL 16 ABUT IC250	6.35	16.0	11.00	0.09	1.50	1.00		●	
11IR 16 ABUT IC908	6.35	16.0	11.00	0.09	1.50	1.00			●
16IR 20 ABUT IC250	9.52	20.0	16.49	0.07	1.30	1.00		●	
16IR 20 ABUT IC908	9.52	20.0	16.49	0.07	1.30	1.00			●
16IL 16 ABUT IC908	9.52	16.0	16.49	0.09	1.50	1.00			●
16IR 16 ABUT IC908	9.52	16.0	16.49	0.09	1.50	1.00			●
16IL 12 ABUT IC908	9.52	12.0	16.49	0.12	2.00	1.40			●
16IR 12 ABUT IC250	9.52	12.0	16.49	0.12	2.00	1.40		●	
16IR 12 ABUT IC908	9.52	12.0	16.49	0.12	2.00	1.40			●
16IL 10 ABUT IC908	9.52	10.0	16.49	0.15	2.40	1.50			●
16IR 10 ABUT IC250	9.52	10.0	16.49	0.15	2.40	1.50		●	
16IR 10 ABUT IC908	9.52	10.0	16.49	0.15	2.40	1.50			●
22IR 8 ABUT IC908	12.70	8.0	22.00	0.18	3.30	2.20			●
22IR 6 ABUT IC908	12.70	6.0	22.00	0.25	3.40	2.20			●
22UIR 4 ABUT IC250	12.70	4.0	22.00	0.41	9.50	2.30	●	●	
22UIR 4 ABUT IC908	12.70	4.0	22.00	0.41	9.77	2.24			●
27UIR 3 ABUT IC908	15.88	3.0	27.50	0.60	11.70	3.10			●

• For Insert Identification System, see page 714 • ANSI B1.9-1973 Class 2 • For technical information and detailed cutting data, see pages 809-825

⁽¹⁾ Threads per inch

For tools, see pages: AVC-D-SIR/L (805) • C#-SIR/L (803) • SIR/L (801)

AMERICAN STANDARD BUTTRESS THREADING FLT-B-A

Double-Ended, Precision, Flat Top Threading Inserts for 7° Lead

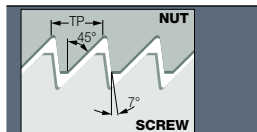
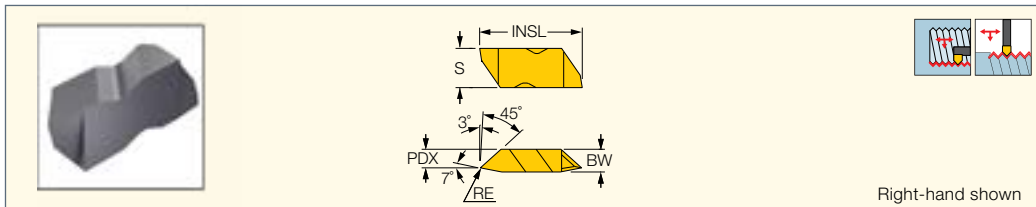

Dimensions

Designation	TPIN ⁽¹⁾	TPIX ⁽²⁾	RE	PDX	BW	S	INSL	IC908
FLT-B-4R/LA IC908	4.00	6.00	0.20	5.20	6.48	11.51	28.45	●
FLT-B-3R/LA IC908	8.00	16.00	0.13	4.20	4.95	8.74	22.60	●
FLT-B-2R/LA IC908	16.00	20.00	0.05	3.20	3.81	5.56	12.95	●

- For user guide, see pages 809-825 • DMIN according to related boring bar • Internal tolerance: ANSI/ASME B1.9 - Class 2B
- External tolerance: ANSI/ASME B1.9 - Class 2A

⁽¹⁾ TPI min.

⁽²⁾ TPI max.

For tools, see pages: FLASR/L (807) • FLSR/L (807)

AMERICAN STANDARD BUTTRESS THREADING FLT-B-B

Double-Ended, Precision, Flat Top Threading Inserts for 45° Lead

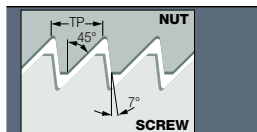
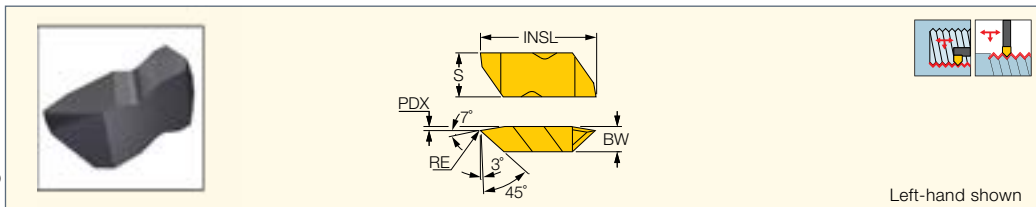

Dimensions

Designation	TPIN ⁽¹⁾	TPIX ⁽²⁾	RE	PDX	BW	S	INSL	IC908
FLT-B-4LB IC908	4.00	6.00	0.20	0.40	6.48	11.51	28.45	●
FLT-B-3R/LB IC908	8.00	16.00	0.13	0.30	4.95	8.74	22.60	●
FLT-B-2R/LB IC908	16.00	20.00	0.05	0.30	3.81	5.56	12.95	●

- For user guide, see pages 809-825 • DMIN according to related boring bar • Internal tolerance: ANSI/ASME B1.9 - Class 2B
- External tolerance: ANSI/ASME B1.9 - Class 2A

⁽¹⁾ TPI min.

⁽²⁾ TPI max.

For tools, see pages: FLASR/L (807) • FLSR/L (807)

ISCAR THREAD

ER/L-API RD

External API - Oil Thread Round Profile Laydown Threading Inserts

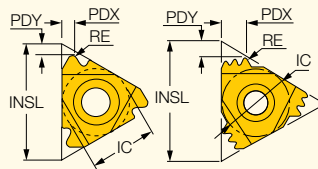

External right-hand shown

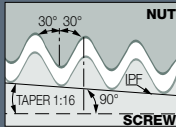

Designation	Dimensions								Tough ↔ Hard	
	IC	IPF	TPI ⁽²⁾	INSL	RE	PDX	PDY	CICT ⁽³⁾	IC250	IC908
16ER 10 API RD IC250	9.52	0.75	10.0	16.49	0.36	1.50	1.20	1	●	
16ER 10 API RD IC908	9.52	0.75	10.0	16.49	0.36	1.50	1.20	1		●
16EL 8 API RD IC908	9.52	0.75	8.0	16.49	0.43	1.60	1.35	1		●
16ER 8 API RD IC250	9.52	0.75	8.0	16.49	0.43	1.60	1.35	1	●	
16ER 8 API RD IC908	9.52	0.75	8.0	16.49	0.43	1.60	1.35	1		●
22ER 10 API RD 2M IC908 ⁽¹⁾	12.70	0.75	10.0	22.00	0.36	3.70	2.40	2		●
27ER 8 API RD 2M IC908 ⁽¹⁾	15.88	0.75	8.0	27.50	0.43	4.50	3.00	2		●

• For Insert Identification System, see page 714 • API Spec 5B8-1996. • For technical information and detailed cutting data, see pages 809-825

⁽¹⁾ Multi-tooth

⁽²⁾ Threads per inch

⁽³⁾ Number of teeth per corner

For tools, see pages: C#-SER/L (799) • NQCH-SER/L-JHP (800) • SBTT#-16ER/L-JHP (418) • SER-D (800) • SER/L (798) • SER/L-JHP (799) • SER/L-JHP-MC (800)

ISCAR THREAD

IR/L-API RD

Internal API - Oil Thread Round Profile Laydown Threading Inserts

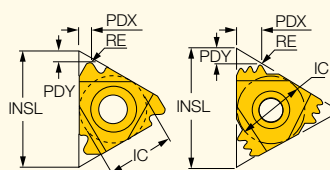

Internal left-hand shown

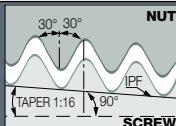

Designation	Dimensions								Tough ↔ Hard	
	IC	IPF	TPI ⁽²⁾	INSL	RE	PDX	PDY	CICT ⁽³⁾	IC250	IC908
16IL 10 API RD IC908	9.52	0.75	10.0	16.49	0.36	1.45	1.30	1		●
16IR 10 API RD IC250	9.52	0.75	10.0	16.49	0.36	1.50	1.30	1	●	
16IR 10 API RD IC908	9.52	0.75	10.0	16.49	0.36	1.50	1.30	1		●
16IL 8 API RD IC250	9.52	0.75	8.0	16.49	0.43	1.45	1.10	1	●	
16IR 8 API RD IC250	9.52	0.75	8.0	16.49	0.43	1.50	1.10	1	●	
16IR 8 API RD IC908	9.52	0.75	8.0	16.49	0.43	1.50	1.10	1		●
22IR 10 API RD 2M IC908 ⁽¹⁾	12.70	0.75	10.0	22.00	0.37	3.70	2.30	2		●
27IR 8 API RD 2M IC908 ⁽¹⁾	15.88	0.75	8.0	27.50	0.43	4.50	3.00	2		●

• For Insert Identification System, see page 714 • API Spec 5B8-1996 • For technical information and detailed cutting data, see pages 809-825

⁽¹⁾ Multi-tooth

⁽²⁾ Threads per inch

⁽³⁾ Number of teeth per corner

For tools, see pages: AVC-D-SIR/L (805) • C#-SIR/L (803) • SIR/L (801)

NOTCH-GRIP
GROOVE-TURN LINE
ISCARTHREAD

**API ROUND THREADING
FLDC-RD-75**
Double-Ended, Precision,
Flat Top Threading Inserts

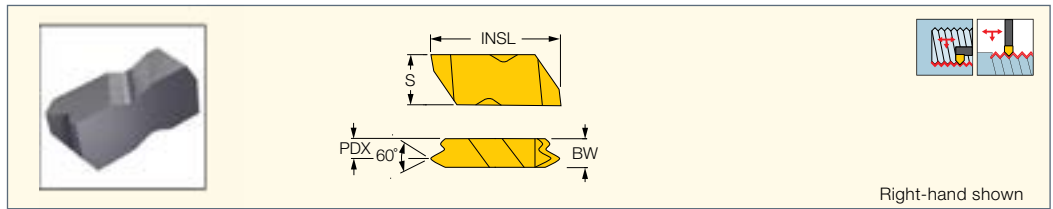

Right-hand shown

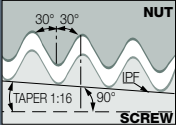
 Designation	Dimensions						IC908
	TPI ⁽¹⁾	IPF	PDX	BW	S	INSL	
FLDC-3-8RDR/L75 IC908	8.0	3/4	5.00	3.18	8.74	22.60	●
FLDC-3-10RDR/L75 IC908	10.0	3/4	5.00	3.18	8.74	22.60	●

• DMIN according to related boring bar • API Spec STD 5B Internal & External tolerance: Standard API RD

⁽¹⁾ Threads per inch

For tools, see pages: FLASR/L (807) • FLSR/L (807)

NOTCH-GRIP
GROOVE-TURN LINE
ISCARTHREAD

**API ROUND THREADING
FLDC-RD-75-CB**
Double-Ended, Precision,
Threading Inserts with
a Chipbreaker

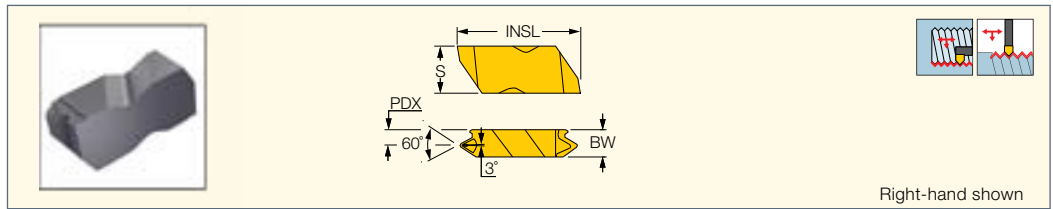

Right-hand shown

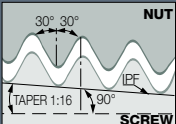
 Designation	Dimensions						IC908
	TPI ⁽¹⁾	IPF	PDX	BW	S	INSL	
FLDC-3-8RDR/L75-CB IC908	8.0	3/4	4.95	3.18	8.74	25.15	●

• DMIN according to related boring bar • API Spec STD 5B Internal & External tolerance: Standard API RD

⁽¹⁾ Threads per inch

For tools, see pages: FLASR/L (807) • FLSR/L (807)

NOTCH-GRIP
GROOVE-TURN LINE
ISCARTHREAD

**API ROUND THREADING
FLDC-RD-75M**
Double-Ended Precision, Flat Top
Multi-Tooth Threading Inserts

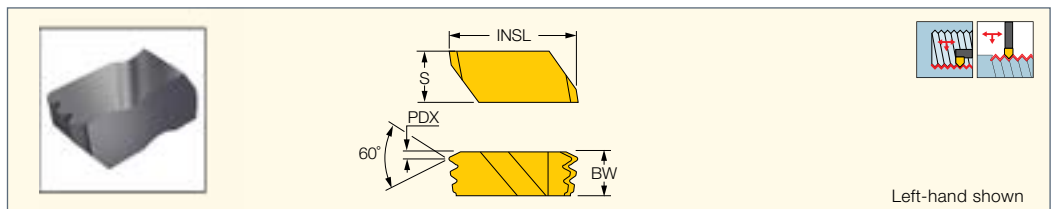

Left-hand shown

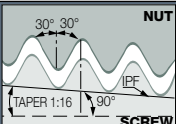
 Designation	Dimensions						IC908
	TPI ⁽¹⁾	IPF	PDX	BW	S	INSL	
FLDC-6-8RDR75 IC908	8.0	3/4	1.80	9.73	11.51	28.45	●

• DMIN according to related boring bar • API Spec STD 5B Internal & External tolerance: Standard API RD

⁽¹⁾ Threads per inch

ISCAR THREAD

ER/L-API
External API - Oil Thread Profile
Laydown Threading Inserts

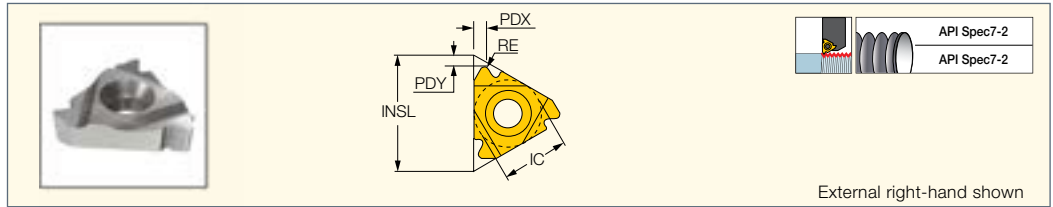

External right-hand shown

Designation	Dimensions									Tough ↔ Hard	
	IC	IPF	TPF	TPI ⁽⁴⁾	INSL	RE	PDX	PDY	Size ⁽⁵⁾	IC250	IC908
22ER 5 API 403 IC250 ⁽¹⁾	12.70	3	3	5.0	22.00	0.49	2.45	1.70	2.375"-4.5"REG	●	
22ER 5 API 403 IC908 ⁽¹⁾	12.70	3	3	5.0	22.00	0.49	2.45	1.70	2.375"-4.5"REG		●
27ER 4 API 403 IC908	15.88	3	3	5.0	27.50	0.51	2.60	2.10	2.375"-4.5"REG		●
27ER 4 API 503 IC908 ⁽²⁾	15.88	3	3	2.0	27.50	0.64	3.10	2.00	5-1/2,7-5/8,8-5/8REG		●
27EL 4 API 502 IC250 ⁽²⁾	15.88	2	2	4.0	27.50	0.64	3.00	2.00	6-5/8" REG	●	
27ER 4 API 502 IC250 ⁽²⁾	15.88	2	2	4.0	27.50	0.64	3.00	2.00	6-5/8" REG	●	
27ER 4 API 502 IC908 ⁽²⁾	15.88	2	2	4.0	27.50	0.64	3.00	2.00	6-5/8" REG		●
27ER 4 API 382 IC250 ⁽³⁾	15.88	2	2	4.0	27.50	0.97	2.90	2.06	NC23-NC50	●	
27ER 4 API 382 IC908 ⁽³⁾	15.88	2	2	4.0	27.50	0.97	2.90	2.06	NC23-NC50		●
27ER 4 API 383 IC908 ⁽³⁾	15.88	3	3	4.0	27.50	0.97	2.90	2.20	NC56-NC77		●

• For Insert Identification System, see page 714 • For technical information and detailed cutting data, see pages 809-825

⁽¹⁾ V-0.040

⁽²⁾ V-0.050

⁽³⁾ V-0.038R

⁽⁴⁾ Threads per inch

⁽⁵⁾ Connection no. or size

For tools, see pages: C#-SER/L (799) • SER-D (800) • SER/L (798)

ISCAR THREAD

IR/L-API
Internal API - Oil Thread Profile
Laydown Threading Inserts

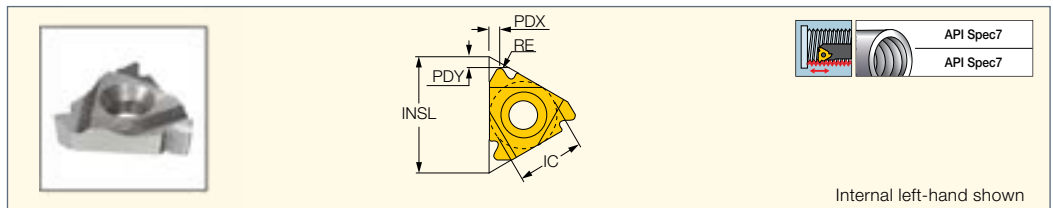

Internal left-hand shown

Designation	Dimensions								Tough ↔ Hard	
	IC	TPI ⁽⁴⁾	INSL	RE	PDX	PDY	Size ⁽⁵⁾	IH	IC250	IC908
22IR 5 API 403 IC250 ⁽¹⁾	12.70	5.0	22.00	0.51	2.40	1.90	2.375"-4.5"REG	R	●	
22IR 5 API 403 IC908 ⁽¹⁾	12.70	5.0	22.00	0.51	2.40	1.90	2.375"-4.5"REG	R		●
27IR 5 API 403 IC908	15.88	5.0	27.50	0.51	2.55	2.10	2.375"-4.5"REG	R		●
27IR 4 API 503 IC250 ⁽²⁾	15.88	4.0	27.50	0.64	3.00	2.10	5-1/2,7-5/8,8-5/8REG	R	●	
27IL 4 API 502 IC250 ⁽²⁾	15.88	4.0	27.50	0.64	3.00	2.00	6-5/8" REG	L	●	
27IR 4 API 502 IC250 ⁽²⁾	15.88	4.0	27.50	0.64	3.00	2.00	6-5/8" REG	R	●	
27IR 4 API 383 IC908 ⁽³⁾	15.88	4.0	27.50	0.97	2.90	2.10	NC56-NC77	R		●
27IR 4 API 382 IC250 ⁽³⁾	15.88	4.0	27.50	0.97	3.00	2.10	NC23-NC50	R	●	
27IR 4 API 382 IC908 ⁽³⁾	15.88	4.0	27.50	0.97	3.00	2.10	NC23-NC50	R		●

• For Insert Identification System, see page 714 • 0.050, API Spec 74-1994 • For technical information and detailed cutting data, see pages 809-825

⁽¹⁾ V-0.040

⁽²⁾ V-0.050

⁽³⁾ V-0.038R

⁽⁴⁾ Threads per inch

⁽⁵⁾ Connection no. or size

For tools, see pages: AVC-D-SIR/L (805) • C#-SIR/L (803) • SIR/L (801)

NOTCH GRIP
GROOVE-TURN LINE
ISCARTHREAD

**API PARTIAL PROFILE
THREADING FLD**
Double-Ended, Precision,
Flat Top Partial Profile
Threading Inserts

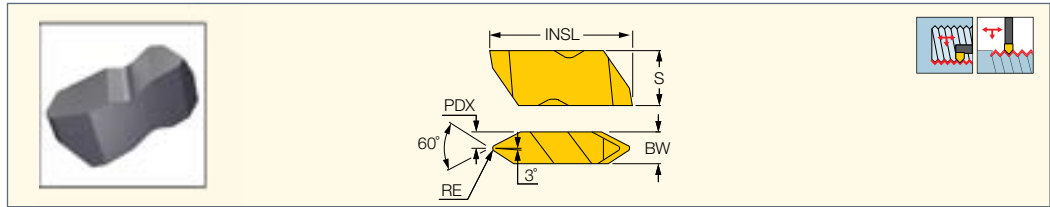

Designation	Dimensions						IC908
	TPI ⁽¹⁾	RE	PDX	BW	S	INSL	
FLD-4050R/L IC908	4.0	0.51	3.25	6.48	11.51	28.45	●
FLD-3038R/L IC908	4.0	0.84	2.08	4.95	8.74	22.60	●
FLD-4038R/L IC908	4.0	0.84	3.25	6.48	11.51	28.45	●
FLD-3040R/L IC908	5.0	0.38	2.08	4.95	8.74	22.60	●
FLD-4040R/L IC908	5.0	0.38	3.25	6.48	11.51	28.45	●

• DMIN according to related boring bar • API Spec7 Internal & External tolerance: API Spec7

⁽¹⁾ Threads per inch

For tools, see pages: FLASR/L (807) • FLSR/L (807)

NOTCH GRIP
GROOVE-TURN LINE
ISCARTHREAD

API THREADING FLDC-E
Double-Ended, Precision,
Flat Top Threading Inserts

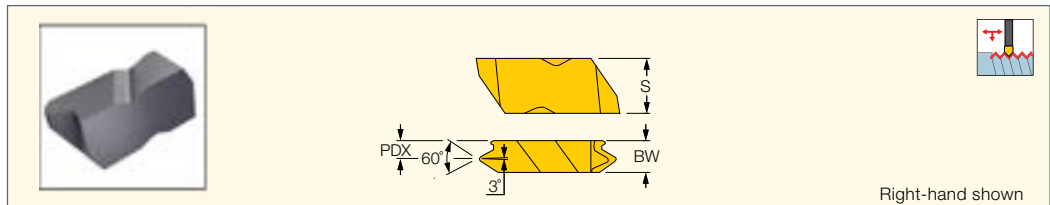

Designation	Dimensions						IC908
	TPI ⁽¹⁾	TPF	PDX	BW	S	INSL	
FLDC-4-425E IC908	4.0	2	4.65	7.92	11.51	28.45	●
FLDC-4-428E IC908	4.0	2	4.65	7.92	11.51	28.45	●
FLDC-4-435E IC908	4.0	3	4.65	7.92	11.51	28.45	●
FLDC-4-438E IC908	4.0	3	4.65	7.92	11.51	28.45	●
FLDC-3-530E IC908	5.0	3	3.73	6.35	8.74	22.60	●

• API Spec7 Internal & External tolerance: API Spec7

⁽¹⁾ Threads per inch

For tools, see pages: FLASR/L (708) • FLSR/L (708)

NOTCH GRIP
GROOVE-TURN LINE
ISCARTHREAD

API THREADING FLDC-I
Double-Ended, Precision,
Flat Top Threading Inserts

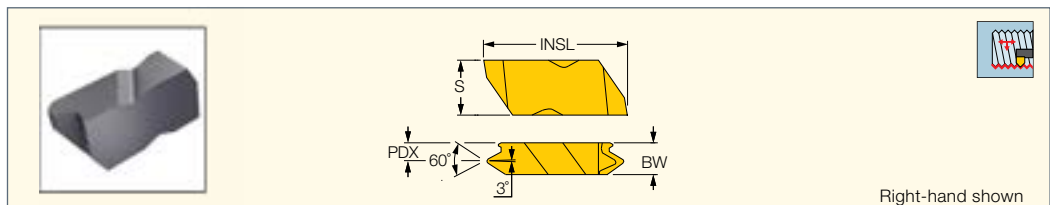

Designation	Dimensions						IC908
	TPI ⁽¹⁾	TPF	PDX	BW	S	INSL	
FLDC-4-425I IC908	4.0	2	4.65	7.92	11.51	28.45	●
FLDC-4-428I IC908	4.0	2	4.65	7.92	11.51	28.45	●
FLDC-4-435I IC908	4.0	3	4.65	7.92	11.51	28.45	●
FLDC-4-438I IC908	4.0	3	4.65	7.92	11.51	28.45	●
FLDC-3-530I IC908	5.0	3	3.73	6.35	8.74	22.60	●

• API Spec7 Internal & External tolerance: API Spec7

⁽¹⁾ Threads per inch

ISCAR THREAD

ER-BUT

External BUT - Oil Thread
Profile Laydown Threading
Inserts for Buttress Casing

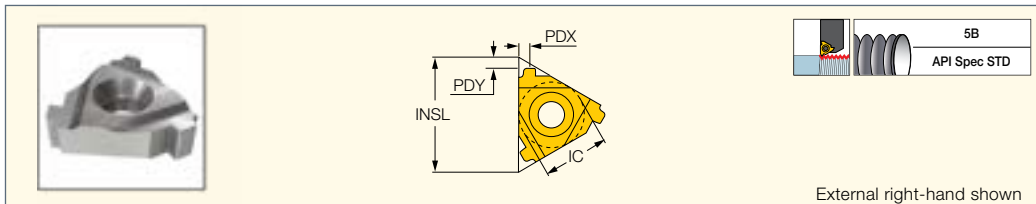

External right-hand shown

Designation	Dimensions							Tough ↔ Hard	
	IC	TPI ⁽¹⁾	IPF	INSL	PDX	PDY	Size ⁽²⁾	IC250	IC908
22ER 5 BUT 0.75 IC250	12.70	5.0	0.75	22.00	2.40	2.20	4-1/2" - 13-3/8"	●	
22ER 5 BUT 0.75 IC908	12.70	5.0	0.75	22.00	2.40	2.20	4-1/2" - 13-3/8"		●
22ER 5 BUT-1.00 IC250	12.70	5.0	1.0	22.00	2.40	2.20	16" - 20"	●	

• For Insert Identification System, see page 714 • API STD.5B • For technical information and detailed cutting data, see pages 809-825

⁽¹⁾ Threads per inch

⁽²⁾ Connection no. or size

For tools, see page: SER/L (798)

ISCAR THREAD

IR-BUT

Internal BUT - Oil Thread
Profile Laydown Threading
Inserts for Buttress Casing

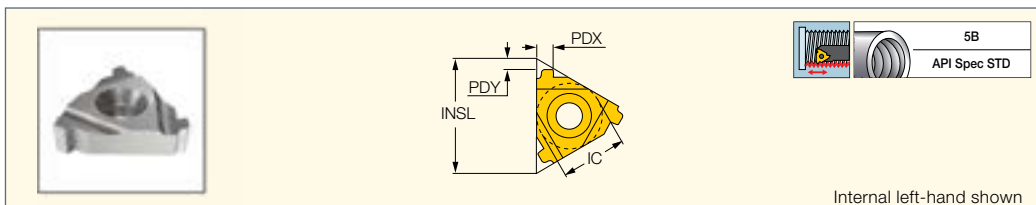

Internal left-hand shown

Designation	Dimensions							Tough ↔ Hard	
	IC	IPF	TPI ⁽¹⁾	INSL	PDX	PDY	Size ⁽²⁾	IC250	IC908
22IR 5 BUT 0.75 IC908	12.70	0.75	5.0	22.00	2.40	2.30	4-1/2" - 13-3/8"		●
22IR 5 BUT 1.00 IC250	12.70	1.00	5.0	22.00	3.50	2.30	16" - 20"	●	

• For Insert Identification System, see page 714 • API STD.5B • For technical information and detailed cutting data, see pages 809-825

⁽¹⁾ Threads per inch

⁽²⁾ Connection no. or size

For tools, see pages: AVC-D-SIR/L (805) • C#-SIR/L (803) • SIR/L (801)

NOTCH GRIP

ISCAR THREAD

API BUTTRESS THREADING FLDC-B-E

Double-Ended, Precision,
Flat Top Threading Inserts

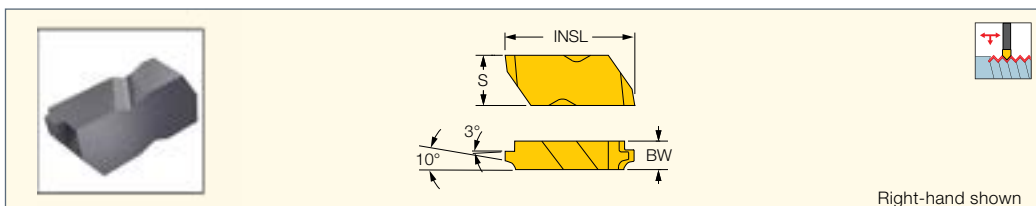

Right-hand shown

Designation	Dimensions						IC908
	TPI ⁽¹⁾	IPF ⁽²⁾	BW	S	INSL		
FLDC-3-5B1E IC908	5.0	1	6.35	8.74	22.60	●	
FLDC-4-5B1E IC908	5.0	1	6.48	11.51	28.45	●	
FLDC-3-5B75E IC908	5.0	3/4	6.35	8.74	22.60	●	
FLDC-4-5B75E IC908	5.0	3/4	6.48	11.51	28.45	●	

• API Spec STD Internal & External tolerance: 5B

⁽¹⁾ Threads per inch

⁽²⁾ Taper Per Foot (TPF) or Inch Per Foot (IPF)

For tools, see pages: FLASR/L (807) • FLSR/L (807)

**API BUTTRESS THREADING
FLDC-B-I**

Double-Ended, Precision,
Flat Top Threading Inserts

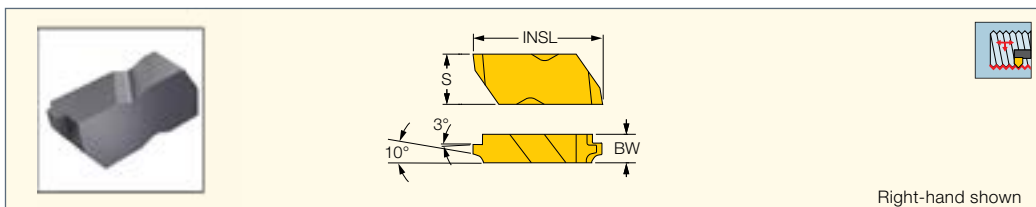

Right-hand shown

Designation	Dimensions					IC908
	TPI ⁽¹⁾	IPF ⁽²⁾	BW	S	INSL	
FLDC-3-5B11 IC908	5.0	1	6.35	8.74	22.60	●
FLDC-4-5B11 IC908	5.0	1	6.48	11.51	28.45	●
FLDC-3-5B75I IC908	5.0	3/4	6.35	8.74	22.60	●
FLDC-4-5B75I IC908	5.0	3/4	6.48	11.51	28.45	●

• API Spec STD Internal & External tolerance: 5B

⁽¹⁾ Threads per inch

⁽²⁾ Taper Per Foot (TPF) or Inch Per Foot (IPF)

ISCARTHREAD

ER-EL
External EL - Extreme Line
Oil Thread Profile Laydown
Threading Inserts

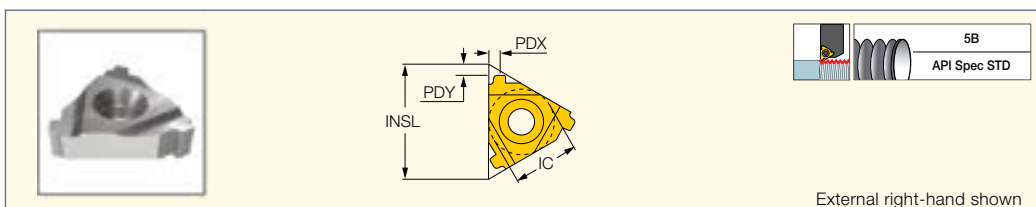

External right-hand shown

Designation	Dimensions							Tough ← Hard	
	IC	TPI ⁽¹⁾	IPF	INSL	PDX	PDY	Size ⁽²⁾	IC250	IC908
22ER 6 EL 1.5 IC250	12.70	6.0	1.5	22.00	1.90	2.10	5" - 7-5/8"	●	●
22ER 6 EL 1.5 IC908	12.70	6.0	1.5	22.00	1.90	2.10	5" - 7-5/8"		●
22ER 5 EL 1.25 IC908	12.70	5.0	1.25	22.00	2.00	2.10	8-5/8" - 10-3/4"		●

• For Insert Identification System, see page 714 • ANSI B1.9.1973 Class 2

⁽¹⁾ Threads per inch

⁽²⁾ Connection no. or size

For tools, see pages: C#-SER/L (799) • SER-D (800) • SER/L (798)

ISCARTHREAD

IR-EL
Internal EL - Extreme Line
Oil Thread Profile Laydown
Threading Inserts

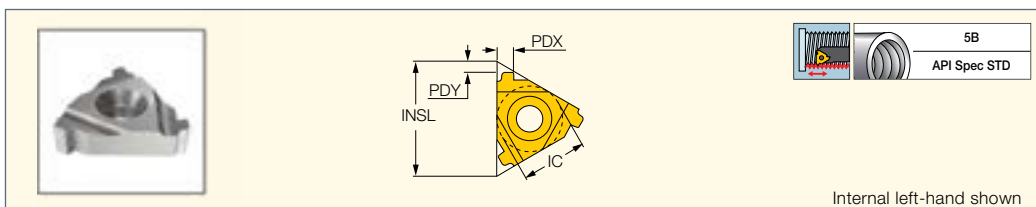

Internal left-hand shown

Designation	Dimensions							IC908
	IC	IPF	TPI ⁽¹⁾	INSL	PDX	PDY	Size ⁽²⁾	
22IR 6 EL 1.5 IC908	12.70	1.5	6.0	22.00	1.90	1.90	5" - 7-5/8"	●

• For Insert Identification System, see page 714 • ANSI B1.9.1973 Class 2

⁽¹⁾ Threads per inch

⁽²⁾ Connection no. or size

For tools, see pages: AVC-D-SIR/L (805) • C#-SIR/L (803) • SIR/L (801)

ISCAR THREAD

ER/L-RND
External DIN 405 Round
Laydown Threading Inserts
for Fire Fighting and Food
Industry Pipe Couplings

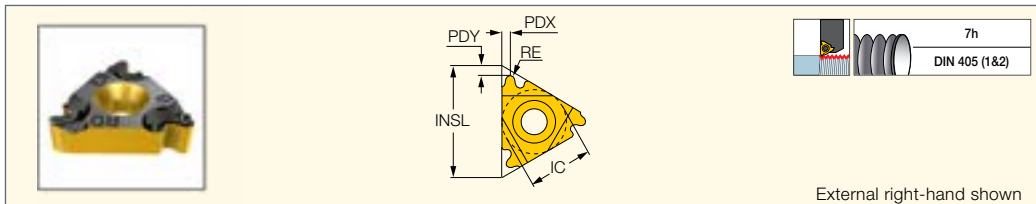

External right-hand shown

Designation	Dimensions						Tough ↔ Hard			
	IC	TPI ⁽²⁾	INSL	RE	PDX	PDY	IC228	IC250	IC508	IC908
16EL 6 RND IC250	9.52	6.0	16.49	1.01	1.70	1.50		●		
16ER 6 RND IC250	9.52	6.0	16.49	1.01	1.70	1.50		●		
16ER 6 RND IC908	9.52	6.0	16.49	1.01	1.60	1.50				●
16ERM 6 RND IC508 ⁽¹⁾	9.52	6.0	16.49	1.01	1.70	1.50			●	
16ERM 6 RND IC908 ⁽¹⁾	9.52	6.0	16.49	1.01	1.70	1.50				●
16EL 8 RND IC250	9.52	8.0	16.49	0.76	1.30	1.40		●		
16EL 8 RND IC908	9.52	8.0	16.49	0.76	1.30	1.40				●
16ER 8 RND IC250	9.52	8.0	16.49	0.76	1.30	1.40		●		
16ER 8 RND IC908	9.52	8.0	16.49	0.76	1.30	1.40				●
16ERM 8 RND IC908 ⁽¹⁾	9.52	8.0	16.49	0.75	1.30	1.40				●
16EL 10 RND IC908	9.52	10.0	16.49	0.61	1.20	1.10				●
16ER 10 RND IC250	9.52	10.0	16.49	0.61	1.20	1.10		●		
16ER 10 RND IC908	9.52	10.0	16.49	0.61	1.30	1.40				●
22EL 4 RND IC908	12.70	4.0	22.00	1.51	2.30	2.20				●
22ER 4 RND IC250	12.70	4.0	22.00	1.51	2.30	2.20		●		
22ER 4 RND IC908	12.70	4.0	22.00	1.51	2.30	2.20				●
22EL 6 RND IC250	12.70	6.0	22.00	1.01	1.70	1.50		●		
22ER 6 RND IC228	12.70	6.0	22.00	1.01	1.70	1.50	●			
22ER 6 RND IC908	12.70	6.0	22.00	1.01	1.70	1.50				●
27ER 4 RND IC250	15.88	4.0	27.50	1.51	2.30	2.20		●		

• For Insert Identification System, see page 714 • Tolerance: Class 7H • For technical information and detailed cutting data, see pages 809-825

⁽¹⁾ With pressed chipformer

⁽²⁾ Threads per inch

For tools, see pages: NQCH-SER/L-JHP (800) • SER/L (798)

ISCAR THREAD

IR/L-RND
Internal DIN 405 Round
Laydown Threading Inserts
for Fire Fighting and Food
Industry Pipe Couplings

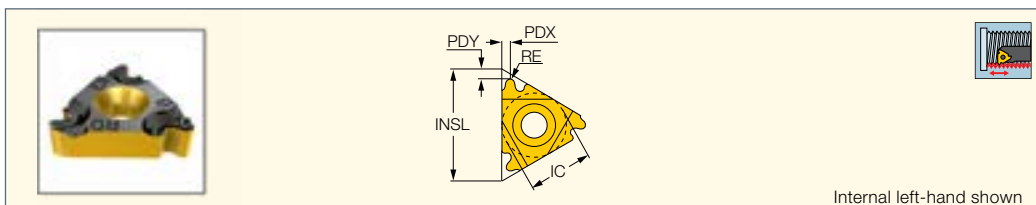

Internal left-hand shown

Designation	Dimensions						Tough ↔ Hard	
	IC	TPI ⁽²⁾	INSL	RE	PDX	PDY	IC250	IC908
16IR 10 RND IC908	9.52	10.0	16.49	0.36	1.20	1.10		●
16IL 8 RND IC908	9.52	8.0	16.49	0.70	1.40	1.40		●
16IR 8 RND IC908	9.52	8.0	16.49	0.70	1.40	1.40		●
16IL 6 RND IC908	9.52	6.0	16.49	0.94	1.50	1.40		●
16IR 6 RND IC250	9.52	6.0	16.49	0.94	1.50	1.40	●	
16IR 6 RND IC908	9.52	6.0	16.49	0.94	1.40	1.50		●
16IRM 6 RND IC908 ⁽¹⁾	9.52	6.0	16.49	0.94	1.50	1.40		●
22IR 6 RND IC908	12.70	6.0	22.00	0.94	1.70	1.50		●
22IR 4 RND IC908	12.70	4.0	22.00	1.40	2.30	2.20		●
27IR 4 RND IC250	15.88	4.0	27.50	1.40	2.30	2.20	●	

• For Insert Identification System, see page 714 • Tolerance: Class 7H • For technical information and detailed cutting data, see pages 809-825

⁽¹⁾ With pressed chipformer

⁽²⁾ Threads per inch

For tools, see pages: AVC-D-SIR/L (805) • C#-SIR/L (803) • SIR/L (801)

Accessories

Thread anvils EL/IR
Thread Anvils for External
Left & Internal Right

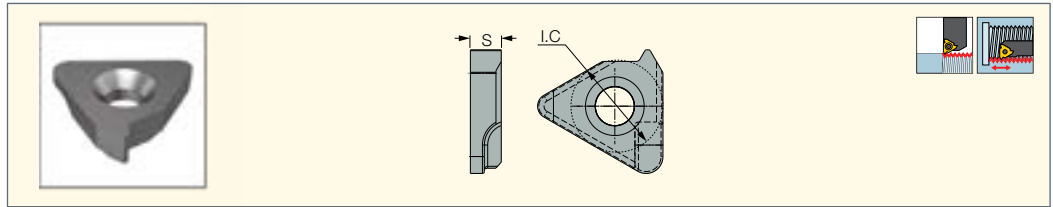

Designation	IC	a°	S
AI16 -0	9.52	0	3.20
AI16M-0	9.52	0	3.20
AI16 -0.50	9.52	-0.5	3.20
AI16 +0.5	9.52	0.5	3.20
AI16M+0.5	9.52	0.5	3.20
AI16 -1.50	9.52	-1.5	3.20
AI16	9.52	1.5	3.20
AI16M	9.52	1.5	3.20
AI16 +2.5	9.52	2.5	3.20
AI16M+2.5	9.52	2.5	3.20
AI16 +3.5	9.52	3.5	3.20
AI16 +4.5	9.52	4.5	3.20
AI22-0	12.70	0	4.00
AI22M-0	12.70	0	4.00
AI22U-0	12.70	0	4.00
AI22 -0.5	12.70	-0.5	4.00
AI22U -0.5	12.70	-0.5	4.00
AI22 +0.50	12.70	0.5	4.00
AI22M+0.5	12.70	0.5	4.00
AI22 -1.50	12.70	-1.5	4.00
AI22U -1.5	12.70	-1.5	4.00
AI22	12.70	1.5	4.00
AI22M	12.70	1.5	4.00
AI22U	12.70	1.5	4.00
AI22 +2.5	12.70	2.5	4.00
AI22M+2.5	12.70	2.5	4.00
AI22U +2.50	12.70	2.5	4.00
AI22 +3.5	12.70	3.5	4.00
AI22U +3.5	12.70	3.5	4.00
AI22 +4.5	12.70	4.5	4.00
AI22U +4.5	12.70	4.5	4.00
AI27-0	15.88	0	5.50
AI27M-0	15.88	0	5.50
AI27U-0	15.88	0	5.50
AI27 -0.5	15.88	-0.5	3.20
AI27U-0.50	15.88	-0.5	5.50
AI27 +0.5-P	15.88	0.5	5.50
AI27M+0.5	15.88	0.5	4.00
AI27U +0.50	15.88	0.5	5.50
AI27 -1.5	15.88	-1.5	5.50
AI27U -1.5	15.88	-1.5	5.50
AI27	15.88	1.5	5.50
AI27M	15.88	1.5	5.50
AI27U	15.88	1.5	5.50
AI27 +2.5	15.88	2.5	5.50
AI27U +2.5	15.88	2.5	5.50
AI27U +2.5TR	15.88	2.5	5.50
AI27 +3.5	15.88	3.5	5.50
AI27U +3.5	15.88	3.5	5.50
AI27U +3.5TR	15.88	3.5	5.50
AI27 +4.5	15.88	4.5	5.50
AI27U +4.5	15.88	4.5	5.50
AI27U +4.5TR	15.88	4.5	5.50

Accessories

Thread anvils ER/IL

Thread Anvils for External
Right & Internal Left

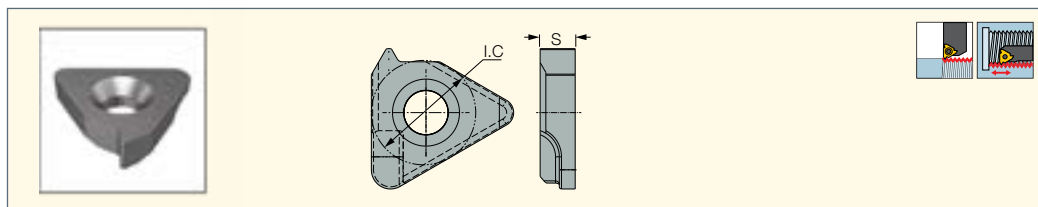

Designation	IC	a°	S
AE16 -0	9.52	0	3.20
AE16M -0	9.52	0	3.20
AE16 -0.5	9.52	-0.5	3.20
AE16M -0.5	9.52	-0.5	3.20
AE16 +0.5	9.52	0.5	3.20
AE16M +0.5	9.52	0.5	3.20
AE16 -1.5	9.52	-1.5	3.20
AE16M -1.5	9.52	-1.5	3.20
AE16	9.52	1.5	3.20
AE16M	9.52	1.5	3.20
AE16 +2.5	9.52	2.5	3.20
AE16M +2.5	9.52	2.5	3.20
AE16 +3.5	9.52	3.5	3.20
AE16 +4.5	9.52	4.5	3.20
AE22 -0	12.70	0	4.00
AE22M -0	12.70	0	4.00
AE22U -0	12.70	0	4.00
AE22 -0.5	12.70	-0.5	4.00
AE22M -0.5	12.70	-0.5	4.00
AE22U -0.5	12.70	-0.5	4.00
AE22 +0.5	12.70	0.5	4.00
AE22M +0.5	12.70	0.5	4.00
AE22U +0.5	12.70	0.5	4.00
AE22 -1.5	12.70	-1.5	4.00
AE22U -1.5	12.70	-1.5	4.00
AE22	12.70	1.5	4.00
AE22M	12.70	1.5	4.00
AE22U	12.70	1.5	4.00
AE22 +2.5	12.70	2.5	4.00
AE22M +2.5	12.70	2.5	4.00
AE22U +2.5	12.70	2.5	4.00
AE22 +3.5	12.70	3.5	4.00
AE22U +3.5	12.70	3.5	4.00
AE22 +4.5	12.70	4.5	4.00
AE22U +4.5	12.70	4.5	4.00
AE27 -0	15.88	0	5.50
AE27M -0	15.88	0	5.50
AE27U -0	15.88	0	5.50
AE27 -0.5	15.88	-0.5	5.50
AE27U -0.5	15.88	-0.5	5.50
AE27 +0.5	15.88	0.5	5.50
AE27M +0.5	15.88	0.5	5.50
AE27U +0.5	15.88	0.5	5.50
AE27 -1.5	15.88	-1.5	5.50
AE27U -1.5	15.88	-1.5	5.50
AE27	15.88	1.5	5.50
AE27M	15.88	1.5	5.50
AE27U	15.88	1.5	5.50
AE27 +2.5	15.88	2.5	5.50
AE27U +2.5	15.88	2.5	5.50
AE27U +2.5TR	15.88	2.5	5.50
AE27 +3.5	15.88	3.5	5.50
AE27U +3.5	15.88	3.5	5.50
AE27U +3.5TR	15.88	3.5	5.50
AE27 +4.5	15.88	4.5	5.50
AE27U +4.5	15.88	4.5	5.50
AE27U +4.5TR	15.88	4.5	5.50

THREADING TOOLS



Toolholder Identification System

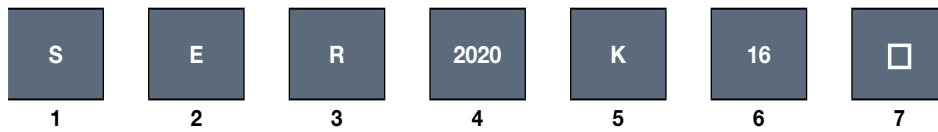

1 Clamping System

S Screw Clamping

2 Application

E External

I Internal

3 Hand of Tool

R Right-hand

L Left-hand

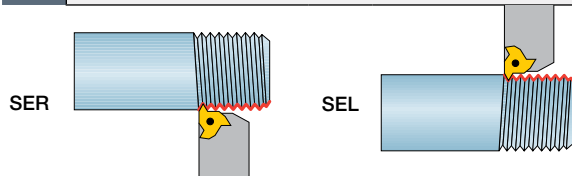

4 Type

External Toolholders

Shank: hxb

2020-20x20 mm

* Optional Prefix

C
HSK
KM } Exchangeable Adaptation System

5 Tool Length

	mm
D	60
F	80
H	100
K	125
L	140
M	150
P	170
R	200
S	250
T	300
U	350
V	400







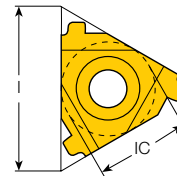

6 Insert Size









l (mm)	IC
06	5/32"
08	3/16"
08U	3/16"
11	1/4"
16	3/8"
22	1/2"
22U	1/2"
27	5/8"
27U	5/8"

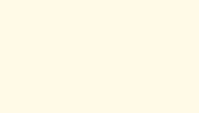

7 Optional Specifications

U	For U-type inserts
B	Bore for coolant
C	Carbide shank
O	Offset style
D	Drop head
G	Gang tool
SP	Special

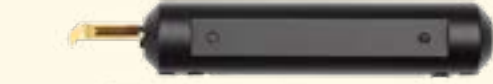
Tool Types	
C#-SER/L HSK-SEL	 Standard 
	 U-Type 
ISCAR GROOVE-TURN TOOLS	
PENTACUT Carrying Inserts with 5 Threading Corners. For tool information, refer to the section on GROOVE-TURN.	

Boring Bars	
E-SIR-HEAD	 Standard 
	 U-Type 
GROOVE-TURN Boring Bars	
CHAMGROOVE Holder and Carbide Bar	
CHAMGROOVE Integral	
PICCOCUT Holders and Carbide Bars	 

SER/L
External Threading Toolholders

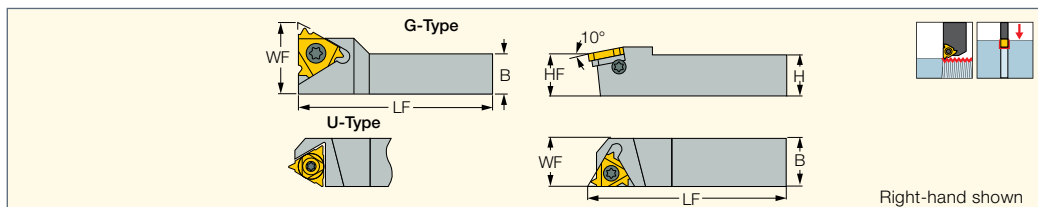

Designation	H	HF	B	LF	WF	Insert ⁽²⁾
SER 0808 H11 ⁽¹⁾	8.0	8.0	8.0	100.00	11.00	11 ER/L..
SER/L 1010 H11 ⁽¹⁾	10.0	10.0	10.0	100.00	11.00	11 ER/L..
SER/L 1212 F16	12.0	12.0	12.0	80.00	12.00	16 ER/L..
SER 1212 X16	12.0	12.0	12.0	120.00	12.00	16 ER/L..
SER/L 1616 H16	16.0	16.0	16.0	100.00	16.00	16 ER/L..
SER 1616 K16G	16.0	16.0	16.0	125.00	21.70	16 ER/L..
SER/L 2020-16-AD	20.0	20.0	20.0	67.00	20.00	16 ER/L..
SER/L 2020 K16	20.0	20.0	20.0	125.00	20.00	16 ER/L..
SER/L 2525 M16	25.0	25.0	25.0	150.00	25.00	16 ER/L..
SER/L 3232 P16	32.0	32.0	32.0	170.00	32.00	16 ER/L..
SER/L 2525 M22	25.0	25.0	25.0	150.00	25.00	22 ER/L..
SER/L 3232 P22	32.0	32.0	32.0	170.00	32.00	22 ER/L..
SER 4040 R22	40.0	40.0	40.0	200.00	40.00	22 ER/L..
SER/L 2525 M22U	25.0	25.0	25.0	150.00	28.00	22 UER/L..
SER/L 3232 P22U	32.0	32.0	32.0	170.00	32.00	22 UER/L..
SEL 4040 R22U	40.0	40.0	40.0	200.00	40.00	22 UER/L..
SER/L 2525 M27	25.0	25.0	25.0	150.00	25.00	27 ER/L..
SER/L 3232 P27	32.0	32.0	32.0	170.00	32.00	27 ER/L..
SER 4040 R27	40.0	40.0	40.0	200.00	40.00	27 ER/L..
SER/L 2525 M27U	25.0	25.0	25.0	150.00	32.00	27 UER/L..
SER/L 3232 P27U	32.0	32.0	32.0	170.00	32.00	27 UER/L..
SER/L 4040 R27U	40.0	40.0	40.0	200.00	40.00	27 UER/L..

• All tools are made for 1.5 helix angle • For multi-tooth inserts use anvils AE16M / A116M; AE22M / A122M; AE27M / A127M • For GTGA inserts, use anvil AE 16-0

⁽¹⁾ Toolholder without anvil

⁽²⁾ Right-hand inserts (ER) for right-hand tools (SER)

For inserts, see pages: EIR/L U (722) • ER/L-55° (715) • ER/L-60° (721) • ER/L-ABUT (784) • ER/L-ACME (771) • ER/L-API (788) • ER/L-API RD (786) • ER/L-BSPT (766) • ER/L-ISO (734) • ER/L-NPT (761) • ER/L-RND (792) • ER/L-STACME (768) • ER/L-TR (780) • ER/L-UN (745) • ER/L-UNJ (775) • ER/L-W (755) • ER/L-SAGE (783) • ER-BUT (790) • ER-EL (791) • ER-PG (782) • ER-MJ (779) • ER-NPTF (765) • ER-ISO 3M-Q (733) • ER-NPT 3M-Q (760) • ER-W 3M-Q (755) • GTGA (365) • GTMA (366)

Spare Parts

Designation					
SER 0808 H11	SR M2.6-L6.7-S11				T-8/5
SER/L 1010 H11	SR M2.6-L6.7-S11				T-8/5
SEL 1212 F16	SR 5-40-L12.2-S16	SR 5-40-L6.8-A16		Al16	T-10/5
SER 1212 F16	SR 5-40-L12.2-S16	SR 5-40-L6.8-A16	AE16		T-10/5
SER 1212 X16	SR 5-40-L12.2-S16	SR 5-40-L6.8-A16	AE16		T-10/5
SEL 1616 H16	SR 5-40-L12.2-S16	SR 5-40-L6.8-A16		Al16	T-10/5
SER 1616 H16	SR 5-40-L12.2-S16	SR 5-40-L6.8-A16	AE16		T-10/5
SER 1616 K16G	SR 5-40-L12.2-S16	SR 5-40-L6.8-A16	AE16		T-10/5
SEL 2020-16-AD	SR 5-40-L12.2-S16	SR 5-40-L6.8-A16		Al16	T-10/5
SER 2020-16-AD	SR 5-40-L12.2-S16	SR 5-40-L6.8-A16	AE16		T-10/5
SEL 2020 K16	SR 5-40-L12.2-S16	SR 5-40-L6.8-A16		Al16	T-10/5
SER 2020 K16	SR 5-40-L12.2-S16	SR 5-40-L6.8-A16	AE16		T-10/5
SEL 2525 M16	SR 5-40-L12.2-S16	SR 5-40-L6.8-A16		Al16	T-10/5
SER 2525 M16	SR 5-40-L12.2-S16	SR 5-40-L6.8-A16	AE16		T-10/5
SEL 3232 P16	SR 5-40-L12.2-S16	SR 5-40-L6.8-A16		Al16	T-10/5
SER 3232 P16	SR 5-40-L12.2-S16	SR 5-40-L6.8-A16	AE16		T-10/5
SEL 2525 M22	SR 8-32-L15-S22	SR 8-32-L5.8-A22		Al22	T-20/5
SER 2525 M22	SR 8-32-L15-S22	SR 8-32-L5.8-A22	AE22		T-20/5
SEL 3232 P22	SR 8-32-L15-S22	SR 8-32-L5.8-A22		Al22	T-20/5
SER 3232 P22	SR 8-32-L15-S22	SR 8-32-L5.8-A22	AE22		T-20/5
SER 4040 R22	SR 8-32-L15-S22	SR 8-32-L5.8-A22	AE22		T-20/5
SEL 2525 M22U	SR 8-32-L15-S22	SR 8-32-L5.8-A22		Al22U	T-20/5
SER 2525 M22U	SR 8-32-L15-S22	SR 8-32-L5.8-A22	AE22U		T-20/5
SEL 3232 P22U	SR 8-32-L15-S22	SR 8-32-L5.8-A22		Al22U	T-20/5
SER 3232 P22U	SR 8-32-L15-S22	SR 8-32-L5.8-A22	AE22U		T-20/5
SEL 4040 R22U	SR 8-32-L15-S22	SR 8-32-L5.8-A22		Al22U	T-20/5
SER 2525 M27	SR M5-L22-S40	SR M5-L5.8-A27		Al27	T-25/3
SER 2525 M27	SR M5-L22-S40	SR M5-L5.8-A27	AE27		T-25/3
SEL 3232 P27	SR M5-L22-S40	SR M5-L5.8-A27		Al27	T-25/3
SER 3232 P27	SR M5-L22-S40	SR M5-L5.8-A27	AE27		T-25/3
SER 4040 R27	SR M5-L22-S40	SR M5-L5.8-A27	AE27		T-25/3
SEL 2525 M27U	SR M5-L22-S40	SR M5-L5.8-A27		Al27U	T-25/3
SER 2525 M27U	SR M5-L22-S40	SR M5-L5.8-A27	AE27U		T-25/3
SEL 3232 P27U	SR M5-L22-S40	SR M5-L5.8-A27		Al27U	T-25/3
SER 3232 P27U	SR M5-L22-S40	SR M5-L5.8-A27	AE27U		T-25/3
SEL 4040 R27U	SR M5-L22-S40	SR M5-L5.8-A27		Al27U	T-25/3
SER 4040 R27U	SR M5-L22-S40	SR M5-L5.8-A27	AE27U		T-25/3

CAMFIX ISCAR THREAD

C#-SER/L

External Threading Tools with
CAMFIX Exchangeable Shanks

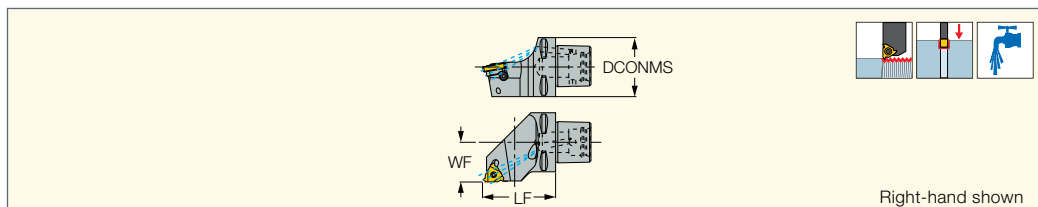

Right-hand shown

Designation	DCONMS	WF	LF	CP ⁽¹⁾	DCP ⁽²⁾	Insert ⁽³⁾
C4 SER/L-27050-16	40.00	27.00	50.00	200	1	16ER/L...
C5 SER/L-35060-16	50.00	35.00	60.00	200	1	16ER/L...
C6 SER/L-45065-16	63.00	45.00	65.00	200	1	16ER/L...
C4 SER/L-27050-22	40.00	27.00	50.00	200	1	22ER/L...
C5 SER/L-35060-22	50.00	35.00	60.00	200	1	22ER/L...
C6 SER/L-45065-22	63.00	45.00	65.00	200	1	22ER/L...
C8 SER/L-55080-22	80.00	55.00	80.00	200	1	22ER/L...

⁽¹⁾ Coolant pressure (Bar)

⁽²⁾ 1 - Slot for data chip, 0 - Without slot for data chip

⁽³⁾ Right-hand inserts for right-hand tools and vice versa

For inserts, see pages: ER-EL (791) • ER-ISO 3M-Q (733) • ER-W 3M-Q (755) • ER/L-55° (715) • ER/L-60° (721) • ER/L-ACME (771) • ER/L-API (788) • ER/L-API RD (786) • ER/L-BSPT (766) • ER/L-ISO (734) • ER/L-NPT (761) • ER/L-SAGE (783) • ER/L-UN (745) • ER/L-UNJ (775) • ER/L-W (755) • GTGA (365) • GTMA (366)

For holders, see page: HSK-C# (835)

Spare Parts

Designation					
C4 SEL-27050-16	AI16	SR 5-40-L6.8-A16	SR 5-40-L12.2-S16	T-10/5	EZ 83
C4 SER-27050-16	AE16	SR 5-40-L6.8-A16	SR 5-40-L12.2-S16	T-10/5	EZ 83
C5 SEL-35060-16	AI16*	SR 5-40-L6.8-A16	SR 5-40-L12.2-S16	T-10/5	EZ 104
C5 SER-35060-16	AE16	SR 5-40-L6.8-A16	SR 5-40-L12.2-S16	T-10/5	EZ 104
C6 SER-45065-16	AI16	SR 5-40-L6.8-A16	SR 5-40-L12.2-S16	T-10/5	EZ 104
C6 SER-45065-16	AE16	SR 5-40-L6.8-A16	SR 5-40-L12.2-S16	T-10/5	EZ 104
C4 SEL-27050-22	AI22	SR 8-32-L5.8-A22	SR 8-32-L15-S22	T-20/5	EZ 83
C4 SER-27050-22	AE22	SR 8-32-L5.8-A22	SR 8-32-L15-S22	T-20/5	EZ 83
C5 SEL-35060-22	AI22	SR 8-32-L5.8-A22	SR 8-32-L15-S22	T-20/5	EZ 104
C5 SER-35060-22	AE22	SR 8-32-L5.8-A22	SR 8-32-L15-S22	T-20/5	EZ 104
C6 SEL-45065-22	AI22	SR 8-32-L5.8-A22	SR 8-32-L15-S22	T-20/5	EZ 104
C6 SER-45065-22	AE22	SR 8-32-L5.8-A22	SR 8-32-L15-S22	T-20/5	EZ 104
C8 SEL-55080-22	AI22	SR 8-32-L5.8-A22	SR 8-32-L15-S22	T-20/5	EZ 125
C8 SER-55080-22	AE22	SR 8-32-L5.8-A22	SR 8-32-L15-S22	T-20/5	EZ 125

* Optional, to be ordered separately

JETCUT ISCAR THREAD

SER/L-JHP

External Threading Tools
with Coolant Channels

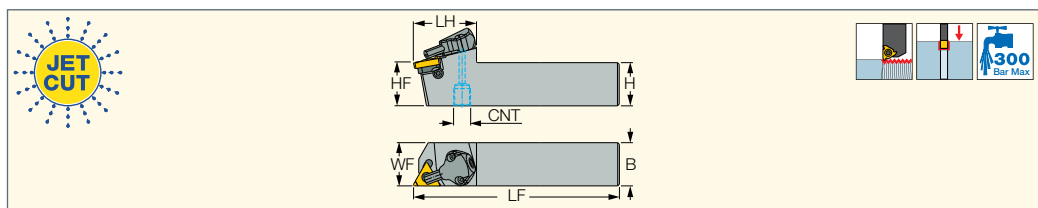

Designation	H	B	HF	LF	LH	WF	CNT	Insert ⁽¹⁾
SER/L 2020 K16-JHP	20.0	20.0	20.0	125.00	37.0	20.00	G1/8-28	16 ER/L..
SER/L 2525 M16-JHP	25.0	25.0	25.0	150.00	37.0	25.00	G1/8-28	16 ER/L..
SER/L 3232 P16-JHP	32.0	32.0	32.0	170.00	37.0	32.00	G1/8-28	16 ER/L..

• All tools are made for 1.5 helix angle • For multi-tooth inserts use anvils AE16M / AI16M; AE22M / AI22M; AE27M / AI27M

• For GTGA inserts, use anvil AE 16-0

⁽¹⁾ Right-hand inserts (ER) for right-hand tools (SER)

For inserts, see pages: ER/L-55° (715) • ER/L-60° (721) • ER/L-ACME (771) • ER/L-API RD (786) • ER/L-BSPT (766) • ER/L-ISO (734)

• ER/L-NPT (761) • ER/L-SAGE (783) • ER/L-UN (745) • ER/L-UNJ (775) • ER/L-W (755) • GTGA (365) • GTMA (366)

Spare Parts

Designation						
SEL 2020 K16-JHP	SR 5-40-L12.2-S16	AI16	T-8/5	SR 5-40-L6.8-A16	T-10/5	CU-V-JHP
SER 2020 K16-JHP	SR 5-40-L12.2-S16	AE16	T-8/5	SR 5-40-L6.8-A16	T-10/5	CU-V-JHP
SEL 2525 M16-JHP	SR 5-40-L12.2-S16	AI16	T-8/5	SR 5-40-L6.8-A16	T-10/5	CU-V-JHP
SER 2525 M16-JHP	SR 5-40-L12.2-S16	AE16	T-8/5	SR 5-40-L6.8-A16	T-10/5	CU-V-JHP
SEL 3232 P16-JHP	SR 5-40-L12.2-S16	AI16	T-8/5	SR 5-40-L6.8-A16	T-10/5	CU-V-JHP
SER 3232 P16-JHP	SR 5-40-L12.2-S16	AE16	T-8/5	SR 5-40-L6.8-A16	T-10/5	CU-V-JHP

JETCUT
ISCARTHREAD

SER/L-JHP-MC
External Threading Tools with
Bottom Inlet Coolant Channels

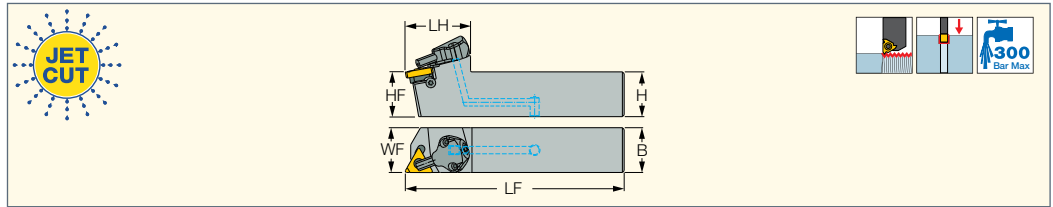

Designation	H	HF	B	LF	LH	WF	Insert ⁽¹⁾
SER/L 2020X16 JHP-MC	20.0	20.0	20.0	107.00	36.2	20.00	16 ER/L..
SER/L 2525X16 JHP-MC	25.0	25.0	25.0	122.00	36.2	25.00	16 ER/L..

- All tools are made for 1.5 helix angle
- For multi-tooth inserts use anvils AE16M / A116M; AE22M / A122M; AE27M / A127M
- For GTGA inserts, use anvil AE 16-0

⁽¹⁾ Right-hand inserts (ER) for right-hand tools (SER)

For inserts, see pages: ER/L-55° (640) • ER/L-60° (644) • ER/L-ACME (677) • ER/L-API RD (688) • ER/L-BSPT (673) • ER/L-ISO (653)
ER/L-NPT (669) • ER/L-SAGE (686) • ER/L-UN (660) • ER/L-UNJ (680) • ER/L-W (666) • GTGA (325) • GTMA (326)

Spare Parts

Designation						
SEL 2020X16 JHP-MC	SR 5-40-L12.2-S16	A116	T-8/5	SR 5-40-L6.8-A16	T-10/5	CU-V-JHP
SER 2020X16 JHP-MC	SR 5-40-L12.2-S16	AE16	T-8/5	SR 5-40-L6.8-A16	T-10/5	CU-V-JHP
SEL 2525X16 JHP-MC	SR 5-40-L12.2-S16	A116	T-8/5	SR 5-40-L6.8-A16	T-10/5	CU-V-JHP
SER 2525X16 JHP-MC	SR 5-40-L12.2-S16	AE16	T-8/5	SR 5-40-L6.8-A16	T-10/5	CU-V-JHP

NEOSWISS JETCUT

NQCH-SER/L-JHP
Screw Lock JETCUT Modular
Heads which Mount ISO
Laydown Threading Inserts
for Swiss-Type Machines

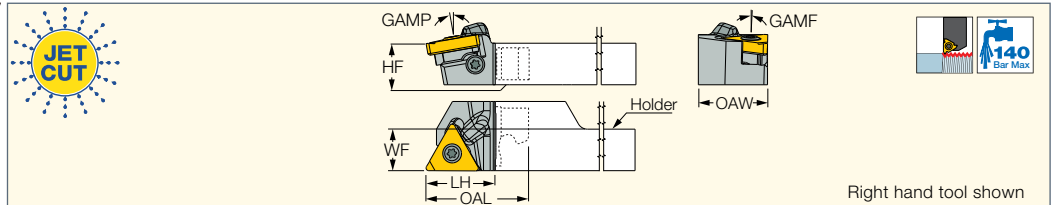

Designation	WF	HF	LH	OAL	OAW	GAMP ⁽¹⁾	GAMF ⁽²⁾	Insert
NQCH12-SEL-16-JHP	12.00	11.8	20.6	29.40	20.00	10.0	1.5	16EL..
NQCH12-SER-16-JHP	12.00	11.8	20.6	29.40	20.00	10.0	1.5	16ER..
NQCH16-SEL-16-JHP	16.00	15.8	20.6	29.40	20.00	10.0	1.5	16EL..
NQCH16-SER-16-JHP	16.00	15.8	20.6	29.40	20.00	10.0	1.5	16ER..

NEW

- Use only RH Shank with RH Head and LH Shank with LH Head

⁽¹⁾ Rake angle axial

⁽²⁾ Rake angle radial

For inserts, see pages: ER-MJ (779) • ER-NPTF (765) • ER-PG (782) • ER/L-55° (715) • ER/L-60° (721) • ER/L-ABUT (784) • ER/L-ACME (771)
ER/L-API RD (786) • ER/L-BSPT (766) • ER/L-ISO (734) • ER/L-NPT (761) • ER/L-RND (792) • ER/L-SAGE (783) • ER/L-STACME (768)
ER/L-TR (780) • ER/L-UN (745) • ER/L-UNJ (775) • ER/L-W (755) • GTGA (365) • GTMA (366)

For holders, see page: NQCH-JHP (424)

Spare Parts

Designation				
NQCH12-SEL-16-JHP	A116	SR 5-40-L6.8-A16	SR 5-40-L12.2-S16	T-10/5
NQCH12-SER-16-JHP	AE16	SR 5-40-L6.8-A16	SR 5-40-L12.2-S16	T-10/5
NQCH16-SEL-16-JHP	A116	SR 5-40-L6.8-A16	SR 5-40-L12.2-S16	T-10/5
NQCH16-SER-16-JHP	AE16	SR 5-40-L6.8-A16	SR 5-40-L12.2-S16	T-10/5

ISCARTHREAD

SER-D
External Threading
Drophead Toolholders

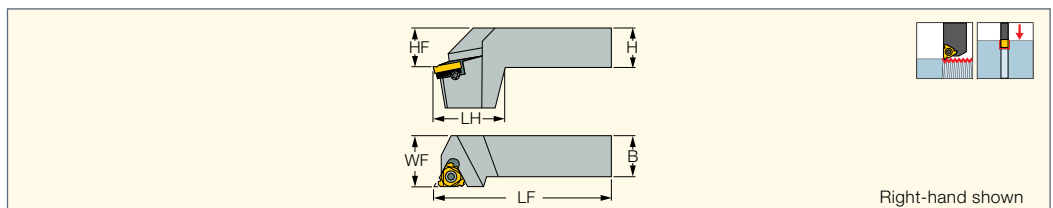

Designation	H	HF	B	LF	WF	LH	Insert				
SER 2525 M16D	25.0	25.0	25.0	150.00	32.00	38.0	16 ER..	SR 5-40-L12.2-S16	T-10/5	AE16	SR 5-40-L6.8-A16
SER 2525 M22D	25.0	25.0	25.0	150.00	32.00	38.0	22 ER..	SR 8-32-L15-S22	T-20/5	AE22	SR 8-32-L5.8-A22

- All toolholders are made for 1.5 helix angle.
- For GTGA inserts, use anvil AE 16-0

For inserts, see pages: ER-ISO 3M-Q (733) • ER-W 3M-Q (755) • GTMA (366)

SIR/L
Internal Threading Bars

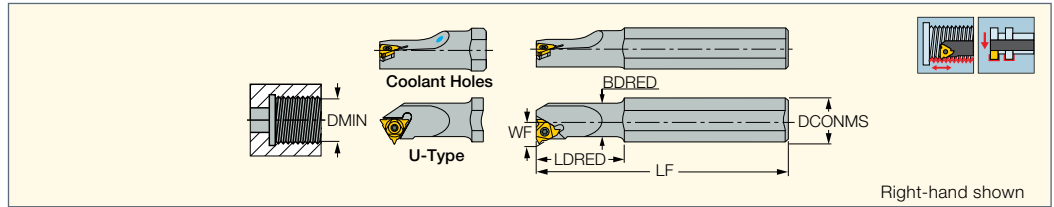

Designation	DMIN	DCONMS	BDRED	LF	LDRED	WF	CSP ⁽⁴⁾	BMC ⁽⁵⁾	Insert ⁽⁶⁾
SIR/L 0005 H06CB ⁽¹⁾	6.40	6.00	5.10	100.00	25.0	4.30	1	H	06 IR/L..
SIR/L 0005 H06 ⁽²⁾	6.40	12.00	5.10	100.00	12.0	4.30	0	S	06 IR/L..
SIR/L 0007 K08CB ⁽¹⁾	9.00	8.00	6.60	125.00	30.0	5.30	1	H	08 IR/L..
SIR/L 0008 K08UCB	9.00	8.00	7.30	125.00	35.0	6.40	1	H	08 UIRL..
SIR/L 0007 K08 ⁽²⁾	9.00	16.00	6.60	125.00	18.0	5.30	0	S	08 IR/L..
SIR/L 0008 K08U ⁽²⁾	9.00	16.00	7.30	125.00	21.0	6.60	0	S	08 UIRL..
SIR/L 0010 H11 ⁽²⁾	12.00	10.00	10.00	100.00	-	7.40	0	S	11 IR/L..
SIR/L 0010 M11CB ⁽¹⁾	12.00	10.00	10.00	150.00	-	7.40	1	H	11 IR/L..
SIR 0010 H11B ⁽²⁾	12.00	10.00	10.00	100.00	-	7.40	1	S	11 IR/L..
SIR/L 0010 K11 ⁽²⁾	12.00	16.00	10.00	125.00	25.0	6.50	0	S	11 IR/L..
SIR/L 0010 K11B ⁽²⁾	12.00	16.00	10.00	125.00	25.0	7.40	1	S	11 IR/L..
SIR/L 0012 P11CB ⁽¹⁾	15.00	12.00	12.00	170.00	-	8.40	1	H	11 IR/L..
SIR/L 0013 L11 ⁽²⁾	15.00	16.00	13.00	140.00	32.0	8.90	0	S	11 IR/L..
SIR/L 0013 M16 ⁽²⁾	16.00	16.00	13.00	150.00	32.0	10.00	0	S	16 IR/L..
SIR/L 0013 M16B ⁽²⁾	16.00	16.00	13.00	150.00	32.0	10.20	1	S	16 IR/L..
SIR/L 0016 R16CB ⁽²⁾	19.00	16.00	16.00	200.00	-	11.70	1	H	16 IR/L..
SIR/L 0016 P16 ⁽²⁾	19.00	20.00	16.00	170.00	40.0	11.40	0	S	16 IR/L..
SIR/L 0016 P16B ⁽²⁾	19.00	20.00	16.00	170.00	40.0	11.70	1	S	16 IR/L..
SIR/L 0020 P16	24.00	20.00	20.00	170.00	-	13.70	0	S	16 IR/L..
SIR/L 0020 P16B	24.00	20.00	20.00	170.00	-	13.70	1	S	16 IR/L..
SIR/L 0020 P22 ⁽²⁾	24.00	20.00	20.00	170.00	-	15.60	0	S	22 IR/L..
SIR/L 0020-16-AD	24.00	20.00	20.00	80.00	-	13.70	0	S	16 IR/L..
SIR 0020 S16CB	24.00	20.00	20.00	250.00	-	13.70	1	H	16 IR/L..
SIR 0025 S16CB	28.00	25.00	25.00	250.00	-	16.20	1	H	16 IR/L..
SIR/L 0025 R16	29.00	25.00	25.00	200.00	-	16.30	0	S	16 IR/L..
SIR/L 0025 R16B	29.00	25.00	25.00	200.00	-	16.20	1	S	16 IR/L..
SIR/L 0025 R22	29.00	25.00	25.00	200.00	-	17.20	0	S	22 IR/L..
SIR/L 0025 R22B	29.00	25.00	25.00	200.00	-	18.10	1	S	22 IR/L..
SIR/L 0025-16-AD	29.00	25.00	25.00	100.00	-	16.20	0	S	16 IR/L..
SIR/L 0032 S16	36.00	32.00	32.00	250.00	-	19.70	0	S	16 IR/L..
SIR/L 0032 S22	38.00	32.00	32.00	250.00	-	21.50	0	S	22 IR/L..
SIR/L 0032 S22U	38.00	32.00	32.00	250.00	-	25.50	0	S	22 UIRL..
SIR/L 0032 S27	40.00	32.00	32.00	250.00	-	22.40	0	S	27 IR/L..
SIR/L 0032 S27U ⁽³⁾	40.00	32.00	32.00	250.00	-	24.70	0	S	27 UIRL..
SIR/L 0040 T16	44.00	40.00	40.00	300.00	-	23.70	0	S	16 IR/L..
SIR/L 0040 T22	46.00	40.00	40.00	300.00	-	25.80	0	S	22 IR/L..
SIR 0040 T22U	46.00	40.00	40.00	300.00	-	29.50	0	S	22 UIRL..
SIR/L 0040 T27	48.00	40.00	40.00	300.00	-	26.60	0	S	27 IR/L..
SIR 0040 T27U ⁽³⁾	48.00	40.00	40.00	300.00	-	29.40	0	S	27 UIRL..
SIR/L 0050 U16	54.00	50.00	50.00	350.00	-	28.70	0	S	16 IR/L..
SIR/L 0050 U22	56.00	50.00	50.00	350.00	-	30.60	0	S	22 IR/L..
SIR/L 0050 U27	58.00	50.00	50.00	350.00	-	31.60	0	S	27 IR/L..
SIR 0050 U27U ⁽³⁾	58.00	50.00	50.00	350.00	-	34.30	0	S	27 UIRL..
SIR/L 0060 V27U ⁽³⁾	68.00	60.00	60.00	400.00	-	39.30	0	S	27 UIRL..
SIR 0060 V27	68.00	60.00	60.00	400.00	-	36.60	0	S	27 IR/L..

• B-steel shank with coolant hole, CB-carbide shank with coolant hole • All toolholders provide 1.5° helix angle, either via the pocket or the anvil supplied

• For GTGA inserts, use anvil AL 16-0

⁽¹⁾ Carbide shank without anvil

⁽²⁾ Toolholder without anvil

⁽³⁾ For ACME, STUB ACME, TRAPEZ (DIN 103) and ROUND (DIN 405) thread profiles check in user guide for anvil information

⁽⁴⁾ 0 - Without coolant supply, 1 - With coolant supply

⁽⁵⁾ H-carbide, S-steel







⁽⁶⁾ Right-hand inserts (IR) for right-hand tools (SIR)

For inserts, see pages: IR/L-55° (716) • IR/L-60° (723) • IR/L-ABUT (784) • IR/L-ACME (772) • IR/L-API (788) • IR/L-API RD (786) • IR/L-BSPT (767) • IR-BUT (790)

• IR-EL (791) • IR-MJ (778) • IR/L-ISO (737) • IR/L-NPT (762) • IR/L-RND (792) • IR/L-STACME (769) • IR/L-TR (781) • IR/L-UN (749) • IR/L-W (757) • IR/L-UNJ (776)

• IR/L-PG (782) • IR/L-SAGE (783) • IR/L-NPTF (765) • GTGA (365) • GTMA (366)

Spare Parts

Designation						
SIR/L 0005 H06CB				SR 14-552	T-6/5	
SIR/L 0005 H06				SR 14-552	T-6/5	
SIR/L 0007 K08CB				SR 14-558	T-6/5	
SIR/L 0008 K08UCB				SR 14-558	T-6/5	
SIR/L 0007 K08				SR 14-558	T-6/5	
SIR/L 0008 K08U				SR 14-558	T-6/5	
SIR/L 0010 H11				SR M2.6-L6.7-S11	T-8/5	
SIR/L 0010 M11CB				SR M2.6-L6.7-S11	T-8/5	
SIR 0010 H11B				SR M2.6-L6.7-S11	T-8/5	
SIR/L 0010 K11				SR M2.6-L6.7-S11	T-8/5	
SIR/L 0010 K11B				SR M2.6-L6.7-S11	T-8/5	PL 16
SIR/L 0012 P11CB				SR M2.6-L6.7-S11	T-8/5	
SIR/L 0013 L11				SR M2.6-L6.7-S11	T-8/5	
SIR/L 0013 M16				SR 5-40-L9.7-S16S	T-10/5	
SIR/L 0013 M16B				SR 5-40-L9.7-S16S	T-10/5	PL 16
SIL 0016 R16CB				SR 5-40-L9.7-S16S	T-10/5	
SIR 0016 R16CB				SR 5-40-L9.7-S16S	T-10/5	
SIR/L 0016 P16				SR 5-40-L9.7-S16S	T-10/5	
SIR/L 0016 P16B				SR 5-40-L9.7-S16S	T-10/5	PL 20
SIL 0020 P16		AE16	SR 5-40-L6.8-A16	SR 5-40-L12.2-S16	T-10/5	
SIL 0020 P16B		AE16	SR 5-40-L6.8-A16	SR 5-40-L12.2-S16	T-10/5	PL 20
SIR/L 0020 P22				SR 8-32-L12-S22S	T-20/5	
SIL 0020-16-AD		AE16	SR 5-40-L6.8-A16	SR 5-40-L12.2-S16	T-10/5	
SIR 0020 P16	Al16		SR 5-40-L6.8-A16	SR 5-40-L12.2-S16	T-10/5	
SIR 0020 P16B	Al16		SR 5-40-L6.8-A16	SR 5-40-L12.2-S16	T-10/5	PL 20
SIR 0020 S16CB	Al16		SR 5-40-L6.8-A16	SR 5-40-L12.2-S16	T-10/5	
SIR 0020-16-AD	Al16		SR 5-40-L6.8-A16	SR 5-40-L12.2-S16	T-10/5	
SIR 0025 S16CB	Al16		SR 5-40-L6.8-A16	SR 5-40-L12.2-S16	T-10/5	
SIL 0025 R16		AE16	SR 5-40-L6.8-A16	SR 5-40-L12.2-S16	T-10/5	
SIL 0025 R16B		AE16	SR 5-40-L6.8-A16	SR 5-40-L12.2-S16	T-10/5	PL 25
SIL 0025 R22		AE22	SR 8-32-L5.8-A22	SR 8-32-L15-S22	T-20/5	
SIL 0025 R22B		AE22	SR 8-32-L5.8-A22	SR 8-32-L15-S22	T-20/5	PL 25
SIL 0025-16-AD		AE16	SR 5-40-L6.8-A16	SR 5-40-L12.2-S16	T-10/5	
SIR 0025 R16	Al16		SR 5-40-L6.8-A16	SR 5-40-L12.2-S16	T-10/5	
SIR 0025 R16B	Al16		SR 5-40-L6.8-A16	SR 5-40-L12.2-S16	T-10/5	PL 25
SIR 0025 R22	Al22		SR 8-32-L5.8-A22	SR 8-32-L15-S22	T-20/5	
SIR 0025 R22B	Al22		SR 8-32-L5.8-A22	SR 8-32-L15-S22	T-20/5	PL 25
SIR 0025-16-AD	Al16		SR 5-40-L6.8-A16	SR 5-40-L12.2-S16	T-10/5	
SIL 0032 S16		AE16	SR 5-40-L6.8-A16	SR 5-40-L12.2-S16	T-10/5	
SIR 0032 S16	Al16		SR 5-40-L6.8-A16	SR 5-40-L12.2-S16	T-10/5	
SIL 0032 S22		AE22	SR 8-32-L5.8-A22	SR 8-32-L15-S22	T-20/5	
SIL 0032 S22U		AE22U	SR 8-32-L5.8-A22	SR 8-32-L15-S22	T-20/5	
SIR 0032 S22	Al22		SR 8-32-L5.8-A22	SR 8-32-L15-S22	T-20/5	
SIR 0032 S22U	Al22U		SR 8-32-L5.8-A22	SR 8-32-L15-S22	T-20/5	
SIL 0032 S27		AE27	SR M5-L5.8-A27	SR M5-L22-S40	T-25/3	
SIL 0032 S27U		AE27U	SR M5-L5.8-A27	SR M5-L22-S40	T-25/3	
SIR 0032 S27	Al27		SR M5-L5.8-A27	SR M5-L22-S40	T-25/3	
SIR 0032 S27U	Al27U		SR M5-L5.8-A27	SR M5-L22-S40	T-25/3	
SIL 0040 T16		AE16	SR 5-40-L6.8-A16	SR 5-40-L12.2-S16	T-10/5	
SIR 0040 T16	Al16		SR 5-40-L6.8-A16	SR 5-40-L12.2-S16	T-10/5	
SIL 0040 T22		AE22	SR 8-32-L5.8-A22	SR 8-32-L15-S22	T-20/5	
SIR 0040 T22	Al22		SR 8-32-L5.8-A22	SR 8-32-L15-S22	T-20/5	
SIR 0040 T22U	Al22U		SR 8-32-L5.8-A22	SR 8-32-L15-S22	T-20/5	
SIL 0040 T27		AE27	SR M5-L5.8-A27	SR M5-L22-S40	T-25/3	
SIR 0040 T27	Al27		SR M5-L5.8-A27	SR M5-L22-S40	T-25/3	
SIR 0040 T27U	Al27U		SR M5-L5.8-A27	SR M5-L22-S40	T-25/3	
SIL 0050 U16		AE16	SR 5-40-L6.8-A16	SR 5-40-L12.2-S16	T-10/5	
SIR 0050 U16	Al16		SR 5-40-L6.8-A16	SR 5-40-L12.2-S16	T-10/5	
SIL 0050 U22		AE22	SR 8-32-L5.8-A22	SR 8-32-L15-S22	T-20/5	
SIR 0050 U22	Al22		SR 8-32-L5.8-A22	SR 8-32-L15-S22	T-20/5	
SIL 0050 U27		AE27	SR M5-L5.8-A27	SR M5-L22-S40	T-25/3	
SIR 0050 U27	Al27		SR M5-L5.8-A27	SR M5-L22-S40	T-25/3	
SIR 0050 U27U	Al27U		SR M5-L5.8-A27	SR M5-L22-S40	T-25/3	
SIL 0060 V27U		AE27U	SR M5-L5.8-A27	SR M5-L22-S40	T-25/3	
SIR 0060 V27	Al27		SR M5-L5.8-A27	SR M5-L22-S40	T-25/3	
SIR 0060 V27U	Al27U		SR M5-L5.8-A27	SR M5-L22-S40	T-25/3	

CAMFIX
ISCARTHREAD

C#-SIR/L

Internal Threading Bars with
CAMFIX Exchangeable Shanks

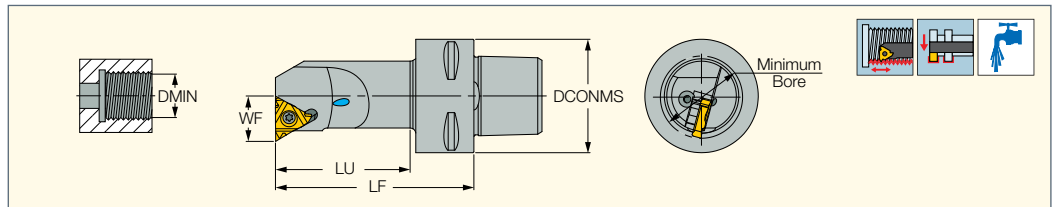





Designation	DCONMS	DMIN	WF	LU	LF	Insert	CP ⁽¹⁾	DCP ⁽²⁾
C4 SIR/L-12060-16	40.00	20.00	11.70	37.0	60.00	16 IR/L..	200	1
C4 SIR/L-14060-16	40.00	25.00	13.50	38.0	60.00	16 IR/L..	200	1
C4 SIR/L-15065-22	40.00	25.00	15.40	42.0	65.00	22 IR/L..	200	1
C4 SIR/L-17070-16	40.00	29.00	16.00	48.0	70.00	16 IR/L..	200	1
C4 SIR/L-19070-22	40.00	29.00	17.90	48.0	70.00	22 IR/L..	200	1
C4 SIR/L-22090-16	40.00	36.00	19.50	69.0	90.00	16 IR/L..	200	1
C4 SIR/L-22090-22	40.00	38.00	21.40	69.0	90.00	22 IR/L..	200	1
C4 SIR/L-27080-16	40.00	44.00	23.50	60.0	80.00	16 IR/L..	200	1
C4 SIR/L-27080-22	40.00	46.00	25.40	60.0	80.00	22 IR/L..	200	1
C5 SIR/L-12060-16	50.00	20.00	11.70	37.0	60.00	16 IR/L..	200	1
C5 SIR/L-12060-16	50.00	20.00	11.70	35.0	60.00	16 IR/L..	200	1
C5 SIR/L-14060-16	50.00	25.00	13.50	36.0	60.00	16 IR/L..	200	1
C5 SIR/L-15065-22	50.00	25.00	15.40	42.0	65.00	22 IR/L..	200	1
C5 SIR/L-14060-16	50.00	25.00	13.50	38.0	60.00	16 IR/L..	200	1
C5 SIR/L-17070-16	50.00	29.00	16.00	48.0	70.00	16 IR/L..	200	1
C5 SIR/L-19070-22	50.00	29.00	17.90	48.0	70.00	22 IR/L..	200	1
C5 SIR/L-22090-16	50.00	36.00	19.50	68.0	90.00	16 IR/L..	200	1
C5 SIR/L-22090-22	50.00	38.00	21.40	68.0	90.00	22 IR/L..	200	1
C5 SIR/L-27105-16	50.00	44.00	23.50	84.0	105.00	16 IR/L..	200	1
C5 SIR/L-27105-22	50.00	46.00	25.40	84.0	105.00	22 IR/L..	200	1
C6 SIR/L-14070-16	63.00	25.00	13.50	45.0	70.00	16 IR/L..	200	1
C6 SIR/L-17075-16	63.00	29.00	16.00	50.0	75.00	16 IR/L..	200	1
C6 SIR/L-19075-22	63.00	29.00	17.90	50.0	75.00	22 IR/L..	200	1
C6 SIR/L-22090-16	63.00	36.00	19.50	65.0	90.00	16 IR/L..	200	1
C6 SIR/L-22090-22	63.00	38.00	21.40	64.0	90.00	22 IR/L..	200	1
C6 SIR/L-27105-16	63.00	44.00	23.50	80.0	105.00	16 IR/L..	200	1
C6 SIR/L-27105-22	63.00	46.00	25.40	80.0	105.00	22 IR/L..	200	1

⁽¹⁾ Coolant pressure (Bar)

⁽²⁾ 1 - Slot for data chip, 0 - Without slot for data chip

For inserts, see pages: GTMA (366) • IR-BUT (790) • IR-EL (791) • IR-MJ (778) • IR/L-55° (716) • IR/L-60° (723) • IR/L-ABUT (784) • IR/L-ACME (772) • IR/L-API (788) • IR/L-API RD (786) • IR/L-BSPT (767) • IR/L-ISO (737) • IR/L-NPT (762) • IR/L-NPTF (765) • IR/L-PG (782) • IR/L-RND (792) • IR/L-SAGE (783) • IR/L-STACME (769) • IR/L-TR (781) • IR/L-UN (749) • IR/L-UNJ (776) • IR/L-W (757) • GTGA (365)

Spare Parts

Designation					
C4 SIL-12060-16		AE16	SR 5-40-L6.8-A16	SR 5-40-L12.2-S16	T-10/5
C4 SIR-12060-16					T-10/5
C4 SIL-14060-16		AE16	SR 5-40-L6.8-A16	SR 5-40-L12.2-S16	T-10/5
C4 SIR-14060-16	Al16		SR 5-40-L6.8-A16	SR 5-40-L12.2-S16	T-10/5
C4 SIR-15065-22					T-20/5
C4 SIL-17070-16		AE16	SR 5-40-L6.8-A16	SR 5-40-L12.2-S16	T-10/5
C4 SIL-19070-22		AE22	SR 8-32-L5.8-A22	SR 8-32-L15-S22	T-20/5
C4 SIR-17070-16	Al16		SR 5-40-L6.8-A16	SR 5-40-L12.2-S16	T-10/5
C4 SIR-19070-22	Al22		SR 8-32-L5.8-A22	SR 8-32-L15-S22	T-20/5
C4 SIL-22090-16		AE16	SR 5-40-L6.8-A16	SR 5-40-L12.2-S16	T-10/5
C4 SIR-22090-16	Al16		SR 5-40-L6.8-A16	SR 5-40-L12.2-S16	T-10/5
C4 SIL-22090-22		AE22	SR 8-32-L5.8-A22	SR 8-32-L15-S22	T-20/5
C4 SIR-22090-22	Al22		SR 8-32-L5.8-A22	SR 8-32-L15-S22	T-20/5
C4 SIL-27080-16		AE16	SR 5-40-L6.8-A16	SR 5-40-L12.2-S16	T-10/5
C4 SIR-27080-16	Al16		SR 5-40-L6.8-A16	SR 5-40-L12.2-S16	T-10/5
C4 SIL-27080-22		AE22	SR 8-32-L5.8-A22	SR 8-32-L15-S22	T-20/5
C4 SIR-27080-22	Al22		SR 8-32-L5.8-A22	SR 8-32-L15-S22	T-20/5
C5 SIR/L-12060-16					T-10/5
C5 SIL-14060-16		AE16	SR 5-40-L6.8-A16	SR 5-40-L12.2-S16	T-10/5
C5 SIL-15065-22		AE22	SR 8-32-L5.8-A22	SR 8-32-L15-S22	T-20/5
C5 SIR-14060-16	Al16		SR 5-40-L6.8-A16	SR 5-40-L12.2-S16	T-10/5
C5 SIR-15065-22	Al22		SR 8-32-L5.8-A22	SR 8-32-L15-S22	T-20/5
C5 SIL-17070-16		AE16	SR 5-40-L6.8-A16	SR 5-40-L12.2-S16	T-10/5
C5 SIL-19070-22		AE22	SR 8-32-L5.8-A22	SR 8-32-L15-S22	T-20/5
C5 SIR-17070-16	Al16		SR 5-40-L6.8-A16	SR 5-40-L12.2-S16	T-10/5
C5 SIR-19070-22	Al22		SR 8-32-L5.8-A22	SR 8-32-L15-S22	T-20/5
C5 SIL-22090-16		AE16	SR 5-40-L6.8-A16	SR 5-40-L12.2-S16	T-10/5
C5 SIR-22090-16	Al16		SR 5-40-L6.8-A16	SR 5-40-L12.2-S16	T-10/5
C5 SIL-22090-22		AE22	SR 8-32-L5.8-A22	SR 8-32-L15-S22	T-20/5
C5 SIR-22090-22	Al22		SR 8-32-L5.8-A22	SR 8-32-L15-S22	T-20/5
C5 SIL-27105-16		AE16	SR 5-40-L6.8-A16	SR 5-40-L12.2-S16	T-10/5
C5 SIR-27105-16	Al16		SR 5-40-L6.8-A16	SR 5-40-L12.2-S16	T-10/5
C5 SIL-27105-22		AE22	SR 8-32-L5.8-A22	SR 8-32-L15-S22	T-20/5
C5 SIR-27105-22	Al22		SR 8-32-L5.8-A22	SR 8-32-L15-S22	T-20/5
C6 SIL-14070-16		AE16	SR 5-40-L6.8-A16	SR 5-40-L12.2-S16	T-10/5
C6 SIR-14070-16	Al16		SR 5-40-L6.8-A16	SR 5-40-L12.2-S16	T-10/5
C6 SIL-17075-16		AE16	SR 5-40-L6.8-A16	SR 5-40-L12.2-S16	T-10/5
C6 SIL-19075-22		AE22	SR 8-32-L5.8-A22	SR 8-32-L15-S22	T-20/5
C6 SIR-17075-16	Al16		SR 5-40-L6.8-A16	SR 5-40-L12.2-S16	T-10/5
C6 SIR-19075-22	Al22		SR 8-32-L5.8-A22	SR 8-32-L15-S22	T-20/5
C6 SIL-22090-16		AE16	SR 5-40-L6.8-A16	SR 5-40-L12.2-S16	T-10/5
C6 SIR-22090-16	Al16		SR 5-40-L6.8-A16	SR 5-40-L12.2-S16	T-10/5
C6 SIL-22090-22		AE22	SR 8-32-L5.8-A22	SR 8-32-L15-S22	T-20/5
C6 SIR-22090-22	Al22		SR 8-32-L5.8-A22	SR 8-32-L15-S22	T-20/5
C6 SIL-27105-16		AE16	SR 5-40-L6.8-A16	SR 5-40-L12.2-S16	T-10/5
C6 SIR-27105-16	Al16		SR 5-40-L6.8-A16	SR 5-40-L12.2-S16	T-10/5
C6 SIL-27105-22		AE22	SR 8-32-L5.8-A22	SR 8-32-L15-S22	T-20/5
C6 SIR-27105-22	Al22		SR 8-32-L5.8-A22	SR 8-32-L15-S22	T-20/5

MGSIR/L
Solid Carbide Bars for Internal
Turning and Threading

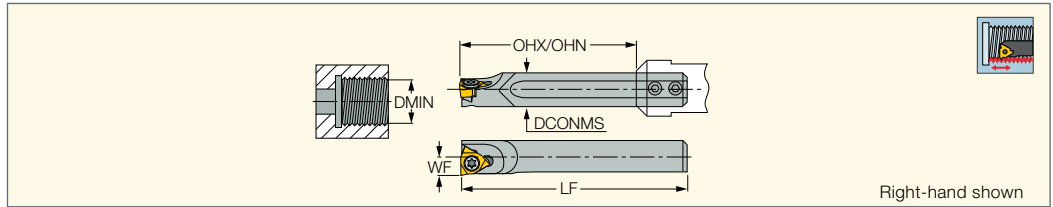

Designation	DCONMS	LF	OHN ⁽¹⁾	OHX ⁽²⁾	WF	DMIN	Insert		
MGSIL 06-06	6.00	59.00	16.0	42.0	3.90	7.00	06 IL../ILM..	SR 14-552	T-6/5
MGSIR 06-06	6.00	59.00	16.0	42.0	3.90	7.00	06 IR../IRM..	SR 14-552	T-6/5
MGSIL 08-06	8.00	72.00	20.0	56.0	5.00	9.20	06 IL../ILM..	SR 14-552	T-6/5
MGSIR 08-06	8.00	72.00	20.0	56.0	5.00	9.20	06 IR../IRM..	SR 14-552	T-6/5

- In order to maintain high machining reliability, we strongly recommend replacing the clamping screw every 10 insert indexes
- ⁽¹⁾ Minimum overhang in adjustment range
- ⁽²⁾ Maximum overhang in adjustment range
- For inserts, see pages:** IR/L-55° (716) • IR/L-60° (723) • IR/L-BSPT (767) • IR/L-ISO (737) • IR/L-NPT (762) • IR/L-NPTF (765) • IR/L-UN (749) • IR/L-W (757)
- For holders, see page:** SC-PICCO (420)

WHISPERLINE

AVC-D-SIR/L
Interchangeable Boring Heads
for Threading Inserts

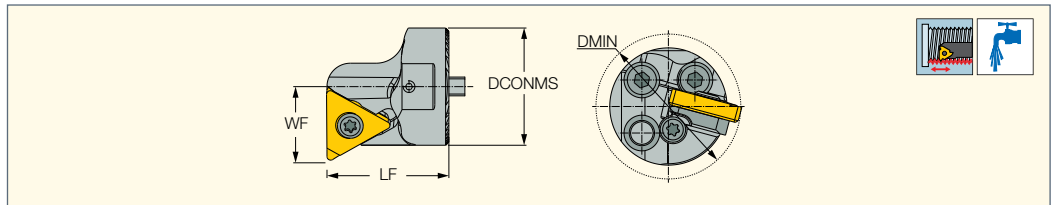

Designation	WF	DCONMS	DMIN	LF	CSP ⁽²⁾
AVC-D25-SIR/L-16	16.20	25.00	29.00	26.00	1
AVC-D32-SIR/L-16	19.70	32.00	36.00	27.00	1
AVC-D40-SIR/L-16 ⁽¹⁾	23.70	40.00	44.00	30.00	1
AVC-D32-SIR/L-22	21.60	32.00	38.00	32.00	1
AVC-D40-SIR/L-22 ⁽¹⁾	25.60	40.00	46.00	38.00	1

- ⁽¹⁾ DMIN of 50mm shank is DMIN of requested head + 10mm • DMIN of 60mm shanks is DMIN of requested head + 20mm
- ⁽²⁾ 0 - Without coolant supply, 1 - With coolant supply
- For inserts, see pages:** GTGA (365) • GTMA (366) • IR-BUT (790) • IR-EL (791) • IR-MJ (778) • IR/L-55° (716) • IR/L-60° (723) • IR/L-ABUT (784) • IR/L-ACME (772) • IR/L-API (788) • IR/L-API RD (786) • IR/L-BSPT (767) • IR/L-ISO (737) • IR/L-NPT (762) • IR/L-NPTF (765) • IR/L-PG (782) • IR/L-RND (792) • IR/L-SAGE (783) • IR/L-STACME (769) • IR/L-TR (781) • IR/L-UN (749) • IR/L-UNJ (776) • IR/L-W (757)
- For holders, see pages:** AV-D (117) • C#-AV-C (118) • C#-SH-E-JHP (704) • C#-SH-JHP (704) • SH-D (116)

Spare Parts

Designation				
AVC-D25-SIL-16	AE16	SR 5-40-L12.2-S16	SR 5-40-L6.8-A16	T-10/5
AVC-D25-SIR-16	AI16	SR 5-40-L12.2-S16	SR 5-40-L6.8-A16	T-10/5
AVC-D32-SIL-16	AE16	SR 5-40-L12.2-S16	SR 5-40-L6.8-A16	T-10/5
AVC-D32-SIR-16	AI16	SR 5-40-L12.2-S16	SR 5-40-L6.8-A16	T-10/5
AVC-D40-SIL-16	AE16	SR 5-40-L12.2-S16	SR 5-40-L6.8-A16	T-10/5
AVC-D40-SIR-16	AI16	SR 5-40-L12.2-S16	SR 5-40-L6.8-A16	T-10/5
AVC-D32-SIL-22	AE22	SR 8-32-L15-S22	SR 8-32-L5.8-A22	T-20/5
AVC-D32-SIR-22	AI22	SR 8-32-L15-S22	SR 8-32-L5.8-A22	T-20/5
AVC-D40-SIL-22	AE22	SR 8-32-L15-S22	SR 8-32-L5.8-A22	T-20/5
AVC-D40-SIR-22	AI22	SR 8-32-L15-S22	SR 8-32-L5.8-A22	T-20/5

CUTGRIP

AVC-GEAIR/L
Internal Grooving, Turning
and Threading Adapters

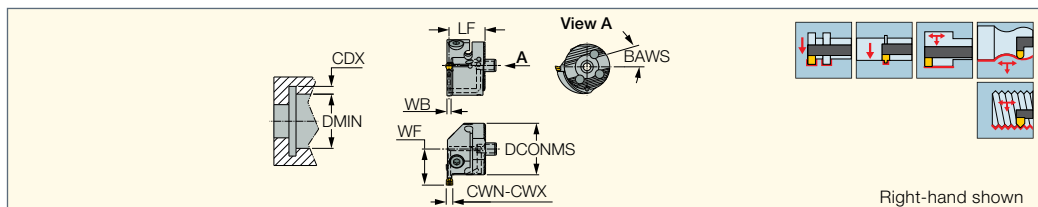

Designation	DMIN	CWN ⁽¹⁾	CWX ⁽²⁾	DCONMS	CDX ⁽³⁾	WF	LF	WB	BAWS	MIID ⁽⁴⁾
AVC-D16-GEAIR/L-2	21.00	1.90	2.40	16.00	3.00	12.00	14.50	1.60	45	GEPI 2.00-0.10
AVC-D16-GEAIR/L-3	21.00	2.40	2.70	16.00	3.00	12.00	14.50	2.00	45	GEPI 3.00-0.20
AVC-D20-GEAIR/L-2	26.00	1.90	2.40	20.00	3.00	14.70	13.50	1.60	15	GEPI 2.00-0.10
AVC-D20-GEAIR/L-3	26.00	2.40	3.18	20.00	3.00	14.70	13.50	2.00	15	GEPI 3.00-0.20
AVC-D25-GEAIR/L-2	31.00	1.90	2.40	25.00	4.00	17.50	17.50	1.60	15	GEPI 2.00-0.10
AVC-D25-GEAIR/L-3	31.00	2.40	3.18	25.00	4.00	17.50	17.50	2.00	15	GEPI 3.00-0.20

• Using the adapters with CAMFIX & SH-D holders is possible in case the machine has an option to rotate the holders • For user guide, see pages 809-825

- (1) Minimum cutting width
- (2) Maximum cutting width
- (3) Cutting depth maximum
- (4) Master insert identification

For inserts, see pages: GEMI (384) • GEMI (full radius) (384) • GEPI (385) • GEPI (full radius) (386) • GEPI-MT (727) • GEPI-WT (718)

For holders, see pages: AV-D (117) • C#-AV-C (118) • C#-SH-E-JHP (704) • C#-SH-JHP (704)

Spare Parts

Designation					
AVC-D16-GEAIR/L-2	SR 14-551				T-9/5
AVC-D16-GEAIR/L-3	SR 14-551				T-9/5
AVC-D20-GEAIR/L-2	SR 34-510		SW6-SD		BLD T15/M7
AVC-D20-GEAIR/L-3	SR 34-510		SW6-SD		BLD T15/M7
AVC-D25-GEAIR/L-2	SR M4X14 DIN912		HW 3.0		
AVC-D25-GEAIR/L-3	SR M4X14 DIN912		HW 3.0		

CUTGRIP

AVC-GAIR/L
Internal Grooving Turning
and Threading Adapters

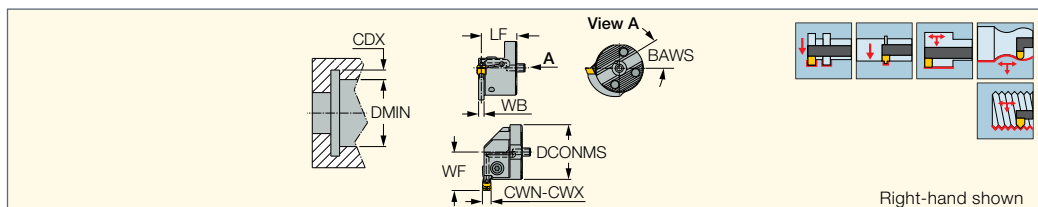

Designation	DMIN	CWN ⁽²⁾	CWX ⁽³⁾	DCONMS	CDX ⁽⁴⁾	WF	LF	WB	BAWS
AVC-D32-GAIR/L-2	37.00	1.50	2.10	32.00	3.00	20.00	23.00	1.20	30
AVC-D32-GAIR/L-3	37.00	2.10	3.00	32.00	3.00	20.00	23.00	1.80	30
AVC-D32-GAIR/L-4	39.00	3.00	4.50	32.00	5.00	22.00	23.00	2.50	30
AVC-D32-GAIR/L-5	39.00	4.50	6.40	32.00	5.00	22.00	26.00	4.00	30
AVC-D40-GAIR/L-2 ⁽¹⁾	45.00	1.50	2.10	40.00	3.00	24.00	23.00	1.20	30
AVC-D40-GAIR/L-3 ⁽¹⁾	46.00	2.10	3.00	40.00	4.00	25.00	23.00	1.80	30
AVC-D40-GAIR/L-4	49.00	3.00	4.50	40.00	7.00	28.00	23.00	2.50	30
AVC-D40-GAIR/L-5	49.00	4.50	6.40	40.00	7.00	28.00	26.00	4.00	30

- When using TIPI inserts, toolholder seat needs to be modified according to insert profile to ensure clearance
- Using the adapters with CAMFIX & SH-D holders is possible in case the machine has an option to rotate the holders
- For user guide, see pages 809-825

(1) DMIN of 50mm shank is DMIN of requested head + 10mm • DMIN of 60mm shanks is DMIN of requested head + 20mm

- (2) Minimum cutting width
- (3) Maximum cutting width
- (4) Cutting depth maximum

For inserts, see pages: GIFI (395) • GIFI-E (392) • GIFI-E (full radius) (392) • GINI-E (393) • GIPI (394) • GIPI (CW<BW) (393)

• GIPI (full radius CW<BW) (394) • GIPI (full radius) (395) • GIPI-E (392) • GIPI-RX/LX (395) • TIPI-MT (728) • TIPI-WT (719)

For holders, see pages: AV-D (117) • C#-AV-C (118) • C#-SH-E-JHP (704) • C#-SH-JHP (704) • SH-D (116)

Spare Parts

Designation			
AVC-GAIR/L	SR 76-1021	T-20/5	SR M3X3DIN913

FLSR/L

Tools for External Grooving and Threading Inserts

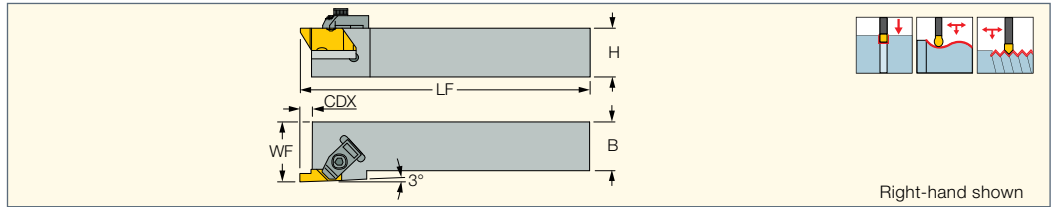

Designation	SSC ⁽¹⁾	H	B	CDX	WF	Insert
FLSR/L-2020M2	2.0	20.0	20.0	3.00	25.00	FL/IN_-2
FLSR/L-2020M3	3.0	20.0	20.0	5.00	25.00	FL/IN_-3
FLSR/L-2525M2	2.0	25.0	25.0	3.00	32.00	FL/IN_-2
FLSR/L-2525M3	3.0	25.0	25.0	5.00	32.00	FL/IN_-3

⁽¹⁾ Seat size code

For inserts, see pages: 60° PARTIAL PROFILE THREADING FLT (730) • 60° PARTIAL PROFILE THREADING FLT-CB (729) • 60° PARTIAL PROFILE THREADING FLTF (728) • 60° PARTIAL PROFILE THREADING FLTK (729) • 60° PARTIAL PROFILE THREADING FLTP (730) • ACME THREADING FLA (773) • ACME THREADING FLA-PT-E (773) • ACME THREADING FLAS (774) • AMERICAN STANDARD BUTTRESS THREADING FLTB-A (785) • AMERICAN STANDARD BUTTRESS THREADING FLTB-B (785) • API BUTTRESS THREADING FLDC-B-E (790) • API PARTIAL PROFILE THREADING FLD (789) • API ROUND THREADING FLDC-RD-75 (787) • API ROUND THREADING FLDC-RD-75-CB (787) • API THREADING FLDC-E (789) • NPT THREADING FLDC-NPT-E (764) • NPT THREADING FLDC-V-75 (764) • STUB ACME THREADING FLAS-PT-E (770) • UN THREADING FLTC-E (754) • UNJ THREADING FLJ (777) • UNJ THREADING FLJF (777) • UNJ THREADING FLJK (778) • UNJ THREADING FLJP (777)

FLASR/L

External Tools for Grooving and Threading intended for Swiss-Type Machines

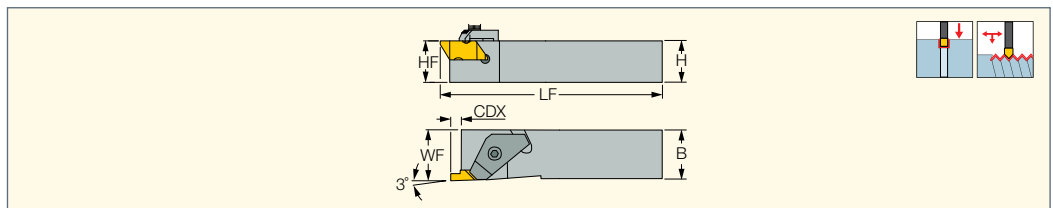

Designation	SSC ⁽¹⁾	H	HF	B	CDX	WF	Insert
FLASR/L-1010M2	2.0	10.0	10.0	10.0	3.51	10.00	FL/IN_-2
FLASR/L-1212M2	2.0	12.0	12.0	12.0	3.51	12.00	FL/IN_-2
FLASR-1616M2	2.0	16.0	16.0	16.0	3.51	16.00	FL/IN_-2
FLASR/L-1616M3	3.0	16.0	16.0	16.0	5.31	16.00	FL/IN_-3

⁽¹⁾ Seat size code

For inserts, see pages: 60° PARTIAL PROFILE THREADING FLT (730) • 60° PARTIAL PROFILE THREADING FLT-CB (729) • 60° PARTIAL PROFILE THREADING FLTF (728) • 60° PARTIAL PROFILE THREADING FLTK (729) • 60° PARTIAL PROFILE THREADING FLTP (730) • ACME THREADING FLA (773) • ACME THREADING FLA-PT-E (773) • ACME THREADING FLAS (774) • AMERICAN STANDARD BUTTRESS THREADING FLTB-A (785) • AMERICAN STANDARD BUTTRESS THREADING FLTB-B (785) • API BUTTRESS THREADING FLDC-B-E (790) • API PARTIAL PROFILE THREADING FLD (789) • API ROUND THREADING FLDC-RD-75 (787) • API ROUND THREADING FLDC-RD-75-CB (787) • API THREADING FLDC-E (789) • NPT THREADING FLDC-NPT-E (764) • NPT THREADING FLDC-V-75 (764) • STUB ACME THREADING FLAS-PT-E (770) • UN THREADING FLTC-E (754) • UNJ THREADING FLJ (777) • UNJ THREADING FLJF (777) • UNJ THREADING FLJK (778) • UNJ THREADING FLJP (777)

For holders, see page: SBTH-JHP (421)

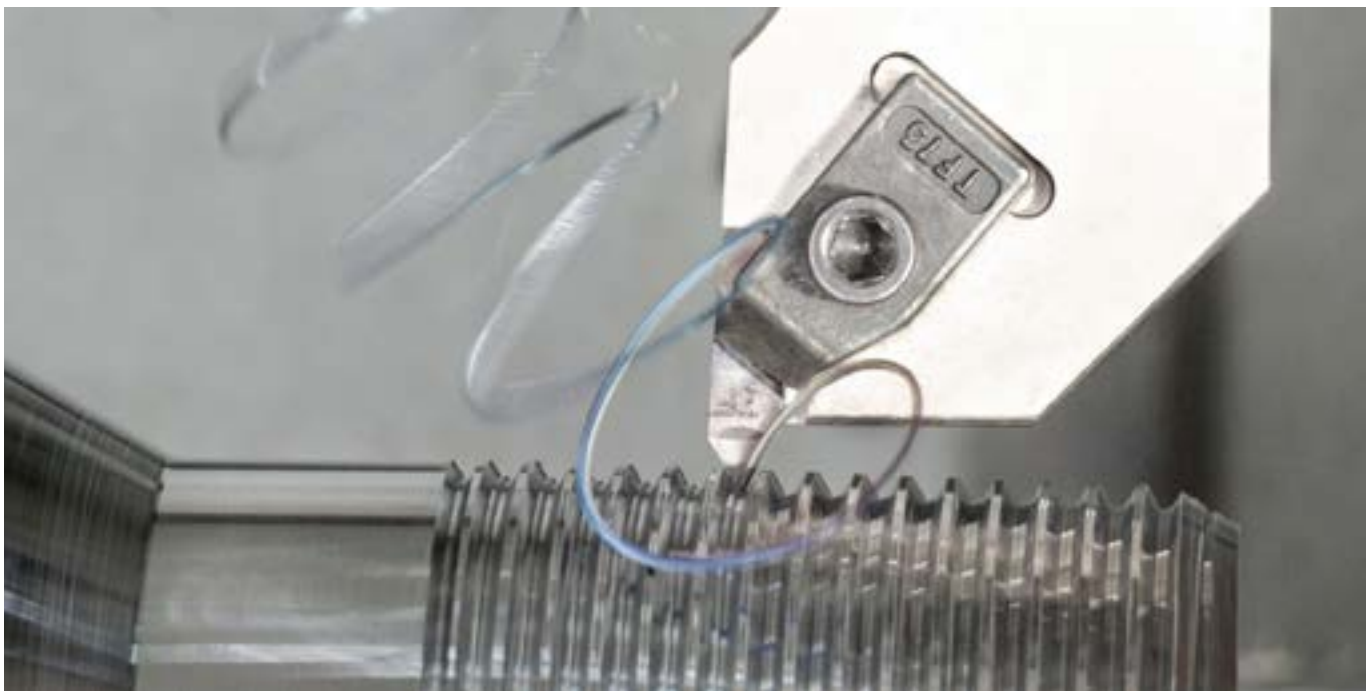

PASSCUT
PICCO CUT HOLDER

PICCO/MG PCO (Holder)

Holders for PICCO-CUT Inserts and Small Diameter Boring Bars

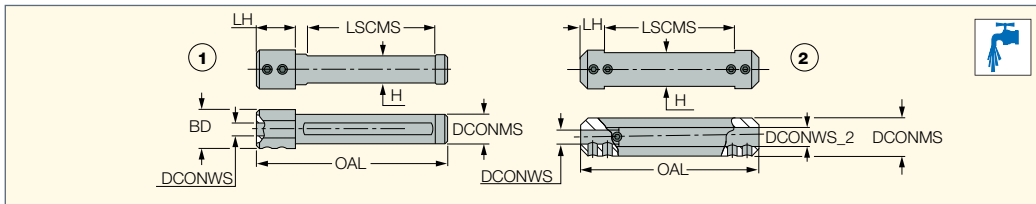

Designation	DCONMS	DCONWS	DCONWS_2	OAL	LH	LSCMS	H	BD	Fig.				
PICCO 12-4-5	12.00	4.00	5.00	75.00	10.0	55.00	10.3	-	2	SR M5X4-PF	HW 2.5	PIN 2X8 ISO2338B	
PICCO 16-4-5	16.00	4.00	5.00	75.00	10.0	55.00	14.0	-	2	SR M5X6-PF	HW 2.5	PIN 2X12 ISO2338B	
PICCO 20-4-5	20.00	4.00	5.00	90.00	10.0	70.00	18.0	-	2	SR M5X6-PF	HW 2.5	PIN 3X16 ISO2338B	
PICCO 22-4-5 (1)	22.00	4.00	5.00	90.00	10.0	70.00	20.0	-	2	SR M5X6-PF	HW 2.5	PIN 3X18 ISO2338B	
PICCO 16-6-7	16.00	6.00	7.00	75.00	10.0	55.00	14.0	-	2	SR M5X6-PF	HW 2.5	PIN 3X12 ISO2338B	
PICCO 20-6-7	20.00	6.00	7.00	90.00	10.0	70.00	18.0	-	2	SR M5X6-PF	HW 2.5	PIN 3X16 ISO2338B	
PICCO 22-6-7 (1)	22.00	6.00	7.00	90.00	10.0	70.00	20.0	-	2	SR M5X6-PF	HW 2.5	PIN 3X18 ISO2338B	
PICCO 25-4-5	25.00	4.00	5.00	90.00	10.0	70.00	23.4	-	2	SR M5X6-PF	HW 2.5		
MG PCO-12-6	12.00	6.00	-	75.00	15.0	50.80	11.0	18.00	1	SR M5X6-PF	HW 2.5		
MG PCO-16-6-8	16.00	6.00	8.00	75.00	10.0	55.00	14.0	-	2	SR M5X6-PF	HW 2.5	MG PCO-SPCR8	
MG PCO-20-6-8	20.00	6.00	8.00	90.00	10.0	70.00	18.0	-	2	SR M5X6-PF	HW 2.5	MG PCO-SPCR8	
MG PCO-22-6-8 (1)	22.00	6.00	8.00	90.00	10.0	70.00	20.0	-	2	SR M5X6-PF	HW 2.5	MG PCO-SPCR8	
MG PCO-25-6-8	25.00	6.00	8.00	90.00	10.0	70.00	23.0	-	2	SR M5X6-PF	HW 2.5	MG PCO-SPCR8	
MG PCO-16-9	16.00	9.00	-	75.00	15.0	53.00	15.0	20.00	1	SR M5X6-PF	HW 2.5		PL 16

- Holders are suitable for right- and left-hand inserts, and boring bars
- (1) Tools for Swiss-type CNC

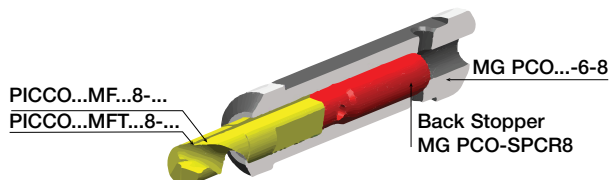

ACECUT
PICCO CUT HOLDER

PICCO ACE

Holders for PICCO-CUT Inserts

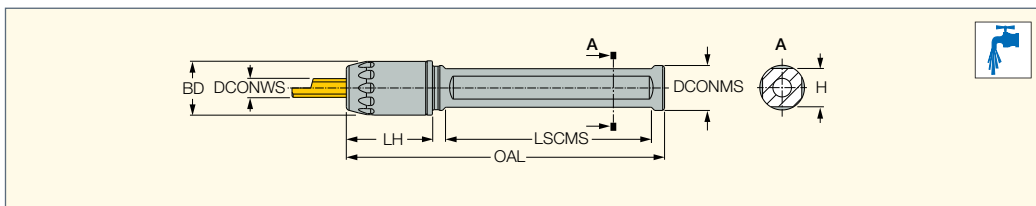

Designation	DCONMS	DCONWS	BD	OAL	LH	LSCMS	H		
PICCO ACE 12-4	12.00	4.00	14.50	85.00	23.00	53.00	10.3	PL 16 M6-D5	WRENCH ACE 4-5
PICCO ACE 12-5	12.00	5.00	14.50	85.00	23.00	53.00	10.3	PL 16 M6-D5	WRENCH ACE 4-5
PICCO ACE 16-4	16.00	4.00	14.50	85.00	21.50	53.50	14.0	PL 16 M6-D5	WRENCH ACE 4-5
PICCO ACE 16-5	16.00	5.00	14.50	85.00	21.50	53.00	14.0	PL 16 M6-D5	WRENCH ACE 4-5
PICCO ACE 16-6	16.00	6.00	19.90	85.00	23.00	53.50	14.0	PL 16 M6-D5	WRENCH ACE 6-7
PICCO ACE 16-7	16.00	7.00	19.90	85.00	23.00	53.50	14.0	PL 16 M6-D5	WRENCH ACE 6-7
PICCO ACE 20-4	20.00	4.00	14.50	150.00	21.50	118.00	18.0	PL 16 M6-D5	WRENCH ACE 4-5
PICCO ACE 20-5	20.00	5.00	14.50	150.00	21.50	118.00	18.0	PL 16 M6-D5	WRENCH ACE 4-5
PICCO ACE 20-6	20.00	6.00	19.90	150.00	21.50	118.00	18.0	PL 16 M6-D5	WRENCH ACE 6-7
PICCO ACE 20-7	20.00	7.00	19.90	150.00	21.50	118.00	18.0	PL 16 M6-D5	WRENCH ACE 6-7
PICCO ACE 22-4	22.00	4.00	14.50	150.00	21.50	118.00	20.0	PL 16 M6-D5	WRENCH ACE 4-5
PICCO ACE 22-5	22.00	5.00	14.50	150.00	21.50	118.00	20.0	PL 16 M6-D5	WRENCH ACE 4-5
PICCO ACE 22-6	22.00	6.00	19.90	150.00	21.50	118.00	20.0	PL 16 M6-D5	WRENCH ACE 6-7
PICCO ACE 22-7	22.00	7.00	19.90	150.00	21.50	118.00	20.0	PL 16 M6-D5	WRENCH ACE 6-7
PICCO ACE 25-4	25.00	4.00	14.50	150.00	21.50	118.00	20.0	PL 16 M6-D5	WRENCH ACE 4-5
PICCO ACE 25-5	25.00	5.00	14.50	150.00	21.50	118.00	20.0	PL 16 M6-D5	WRENCH ACE 4-5
PICCO ACE 25-6	25.00	6.00	19.90	150.00	21.50	118.00	20.0	PL 16 M6-D5	WRENCH ACE 6-7
PICCO ACE 25-7	25.00	7.00	19.90	150.00	21.50	118.00	20.0	PL 16 M6-D5	WRENCH ACE 6-7

- Holders are suitable for right- and left-hand PICCO inserts

For tools, see pages: PICIN-A-SCLCR/L (464) • PICIN-A-SIR/L (466) • PICIN-A-SWUBR/L (465) • PICIN-MGSIR/L (466) • PICIN-SCLCR/L (464) • PICIN-SWUBR/L (465)

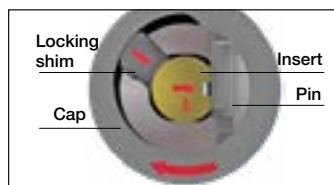
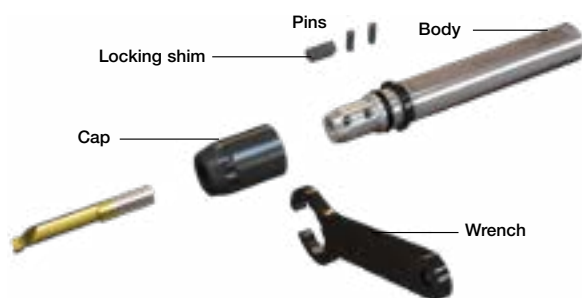

Machining Data for Threading

ISO	Material	Condition	Tensile Strength (N/mm ²)	Hardness HB	Material Group No.	Coated				
						IC228	IC908	IC808	IC1007	
						Cutting Speed (m/min)				
P	non-alloy steel and cast steel, free cutting steel	<0.25% C	annealed	420	125	1	60-100	115-190	125-205	135-230
		≥0.25% C	annealed	650	190	2	60-95	110-180	120-195	130-220
		<0.55% C	quenched and tempered	850	250	3	50-90	100-175	105-185	120-210
			annealed	750	220	4	45-85	90-165	95-175	110-200
	low alloy and cast steel (less than 5% of alloying elements)	≥0.55% C	quenched and tempered	1000	300	5	45-85	90-165	95-175	110-200
			annealed	600	200	6	50-95	100-180	105-195	120-215
		annealed	quenched and tempered	930	275	7	40-75	75-140	80-150	90-170
				1000	300	8	35-70	70-135	75-145	85-160
	high alloyed steel, cast steel and tool steel	annealed	680	200	10	40-65	80-120	85-130	95-145	
			quenched and tempered	1100	325	11	25-50	50-100	55-105	60-120
	stainless steel and cast steel	ferritic / martensitic	680	200	12	35-70	70-130	75-140	85-155	
			martensitic	820	240	13	45-60	85-110	90-120	100-130
	M	stainless steel and cast steel	austenitic, duplex	600	180	14	45-75	90-140	95-150	110-170
K	gray cast iron (GG)	ferritic / pearlitic		180	15	65-85	125-160	135-170	150-190	
		pearlitic / martensitic		260	16	45-65	90-120	95-130	110-145	
	nodular cast iron (GGG)	ferritic		160	17	35-70	70-130	75-140	85-155	
		pearlitic		250	18	30-60	60-115	65-125	70-140	
	malleable cast iron	ferritic		130	19	30-35	60-70	65-75	70-85	
pearlitic			230	20	30-75	60-145	65-155	70-175		
N	aluminum-wrought alloys	not hardenable		60	21	50-195	100-365	105-390	120-440	
		hardenable		100	22	40-115	80-220	85-235	95-265	
	aluminum-cast alloys	≤12% Si	not hardenable		75	23	105-215	200-400	215-430	240-480
			hardenable		90	24	105-150	200-280	215-300	240-335
		>12% Si	high temperature		130	25	105-150	200-280	215-300	240-335
	copper alloys	>1% Pb	free cutting		110	26	40-135	80-255	85-275	95-305
			brass		90	27	40-135	80-255	85-275	95-305
			electrolytic copper		100	28	40-130	80-255	85-275	95-305
non metallic	duroplastics, fiber plastics				29	40-130	80-250	85-265	95-300	
		hard rubber			30	40-130	80-250	85-265	95-300	
S	high temperature alloys	Fe based	annealed		200	31	25-30	45-60	50-65	55-70
			hardened		280	32	15-25	35-50	35-55	40-60
		Ni or Co based	annealed		250	33	10-15	20-30	20-30	25-35
			hardened		350	34	5-10	15-25	15-25	18-30
	titanium alloys	cast		320	35	5-10	15-25	15-25	18-30	
		pure	400		36	75-90	140-170	150-180	170-205	
alpha+beta alloys, hardened	1050		37	25-35	50-70	55-75	60-85			
	hardened steel	hardened		55 HRC	38	25-30	45-60	50-65	55-70	
hardened			60 HRC	39	25-30	45-60	50-65	55-70		
H	chilled cast iron	cast		400	40	25-30	45-60	50-65	55-70	
	cast iron	hardened		55 HRC	41	25-30	45-60	50-65	55-70	

Threading Materials Grades Chart

	Grade	ISO	Grade Description	Coating Layers	Coating Color*
PVD COATED	IC228	P30-P45	A very tough substrate with PVD coating, suitable for machining steels and stainless steel at low to medium cutting speeds.		
		M25-M40			
	IC250	P15-P35	A tough substrate with PVD coating. Suitable for machining steels and alloy steels at low to medium cutting speeds.		
		M20-M40			
	IC806		A hard submicron grain size substrate with PVD coating and a special SUMOTEC surface treatment. Excellent for machining high temperature alloys and Titanium alloys, at moderate to relatively high cutting speeds. Features high wear resistance and plastic deformation durability.		
		M05-M15			
		S10-S20			
	IC808	P15-P30	A tough submicron grain size substrate with PVD coating and a special SUMOTEC surface treatment. Recommended for general use for a large variety of applications and materials such as steels, alloy steels, austenitic stainless steel and high temperature alloys at moderate cutting speeds and feeds. Features high wear resistance and chipping durability.		
		M20-M30			
		K20-K40			
		S15-S30			
		H20-H30			
	IC908	P15-P30	A tough submicron grain size substrate with PVD coating, recommended for general use in a large variety of operations and materials such as steels, alloy steels, austenitic stainless steel and high temperature alloys at moderate cutting speeds. Features high wear resistance and chipping durability.		
M20-M30					
K20-K40					
S15-S30					
H20-H30					
IC1007	P10-P20	A hard submicron grain size substrate with PVD coating, suitable for a wide range of materials such as steels, alloy steels, hard steels, austenitic stainless steel and heat resistant alloys at moderate to high speeds under stable conditions. Features high wear resistance and plastic deformation durability. Good choice for non-ferrous materials and cast iron.			
	M05-M15				
	K15-K30				
	S10-S20				
	H05-H15				

* For coated grades

	Grade	ISO	Grade Description	Coating Layers	Uncoated
UNCOATED	IC08		A tough uncoated submicron carbide grade, suitable for steels, stainless steel and high temperature alloys at low cutting speeds. Good choice for non-ferrous materials.		
		M15-M30			
		N10-N25			
		S20-S30			

User Guide and Cutting Data

Types and Profiles of Threading Inserts

Partial Profile

- Performs different thread standards and is suitable for a wide range of pitches that have a common angle (60° or 55°)
- Inserts with a small root-corner radius suitable for the smallest pitch of the range
- Additional operations to complete the outer/ internal diameter are necessary
- Not recommended for mass production
- Eliminates the need for different inserts

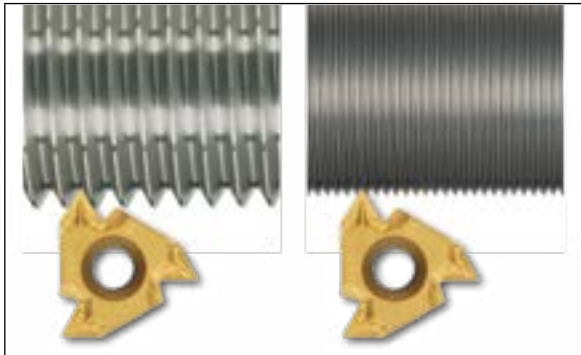

Full Profile

- Performs a complete thread profile
- Root corner radius is only suitable for the relevant pitch
- Recommended for mass production
- Suitable for one profile only



Thread Turning Methods

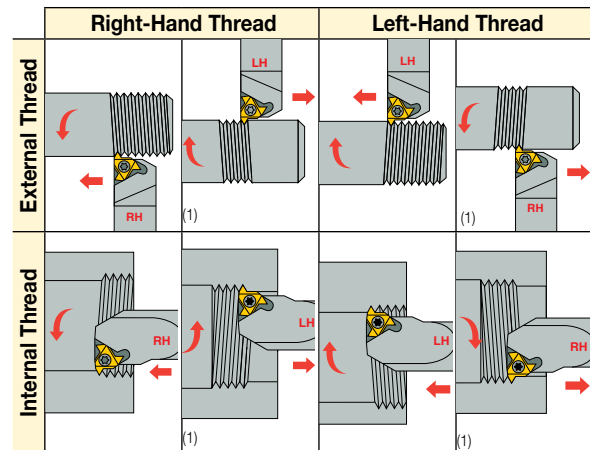

(1) Change anvil to negative

Anvil Selection According to Thread Helix Angle λ

		Standard						
Thread Helix Angle λ		$>4^\circ$	$3^\circ-4^\circ$	$2^\circ-3^\circ$	$1^\circ-2^\circ$	$0^\circ-1^\circ$	Negative Anvils	
Inclination Angle β		4.5°	3.5°	2.5°	1.5°	0.5°	-0.5°	-1.5°
I (d)	Toolholder	Anvil Designation						
16	EX RH OR IN LH	AE16+4.5	AE16+3.5	AE16+2.5	AE16	AE16+0.5	AE16-0.5	AE16-1.5
(3/8)	EX LH OR IN RH	AI16+4.5	AI16+3.5	AI16+2.5	AI16	AI16+0.5	AI16-0.5	AI16-1.5
22	EX RH OR IN LH	AE22+4.5	AE22+3.5	AE22+2.5	AE22	AE22+0.5	AE22-0.5	AE22-1.5
(1/2)	EX LH OR IN RH	AI22+4.5	AI22+3.5	AI22+2.5	AI22	AI22+0.5	AI22-0.5	AI22-1.5
27	EX RH OR IN LH	AE27+4.5	AE27+3.5	AE27+2.5	AE27	AE27+0.5	AE27-0.5	AE27-1.5
(5/8)	EX LH OR IN RH	AI27+4.5	AI27+3.5	AI27+2.5	AI27	AI27+0.5	AI27-0.5	AI27-1.5
22U	EX RH OR IN LH	AE22U+4.5	AE22U+3.5	AE22U+2.5	AE22U	AE22U+0.5	AE22U-0.5	AE22U-1.5
(1/2U)	EX LH OR IN RH	AI22U+4.5	AI22U+3.5	AI22U+2.5	AI22U	AI22U+0.5	AI22U-0.5	AI22U-1.5
27U	EX RH OR IN LH	AE27U+4.5	AE27U+3.5	AE27U+2.5	AE27U	AE27U+0.5	AE27U-0.5	AE27U-1.5
(5/8U)	EX LH OR IN RH	AI27U+4.5	AI27U+3.5	AI27U+2.5	AI27U	AI27U+0.5	AI27U-0.5	AI27U-1.5

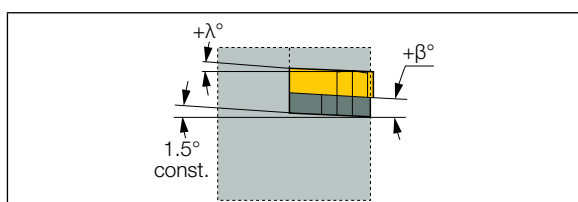

Anvils for positive inclination angle applicable when turning RH thread with RH holders or LH thread with LH toolholders.

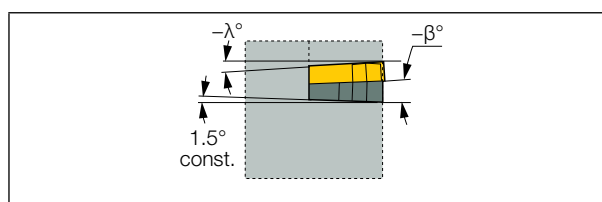

Anvils for negative inclination used when turning RH thread with LH holder or LH thread with RH toolholder.

Anvils for Laydown Inserts

The parameter for tilting the threading insert relative to the helix angle of threading is of great importance when threading is produced. This parameter ensures proper operation of the insert during threading production in terms of equal load distribution applied to the insert, equal distribution of forces operating on the insert, development of uniform wear on both sides of the cutting edge, and avoiding friction of the insert with the side of the threading profile. If the side clearance insert angles (α) are not equal in relation to the helix angle (ϕ), the insert must be tilted. This is performed by using anvils.

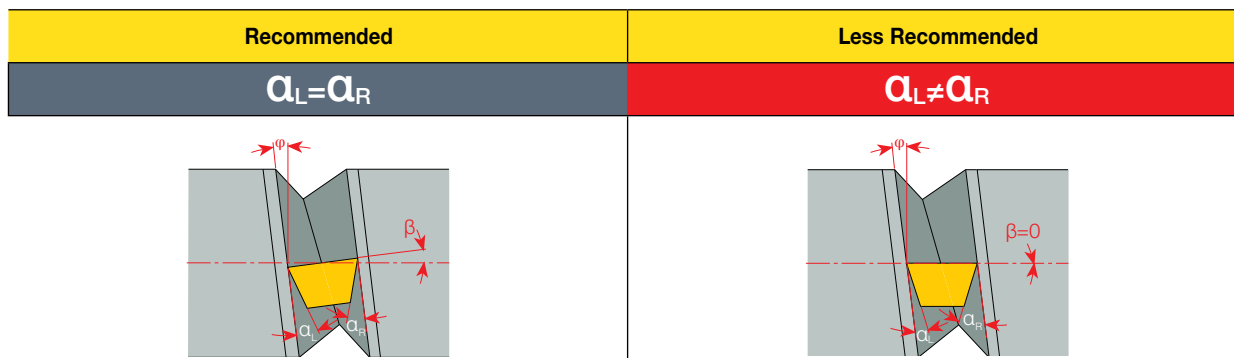

Quick and easy way to select a correct anvil

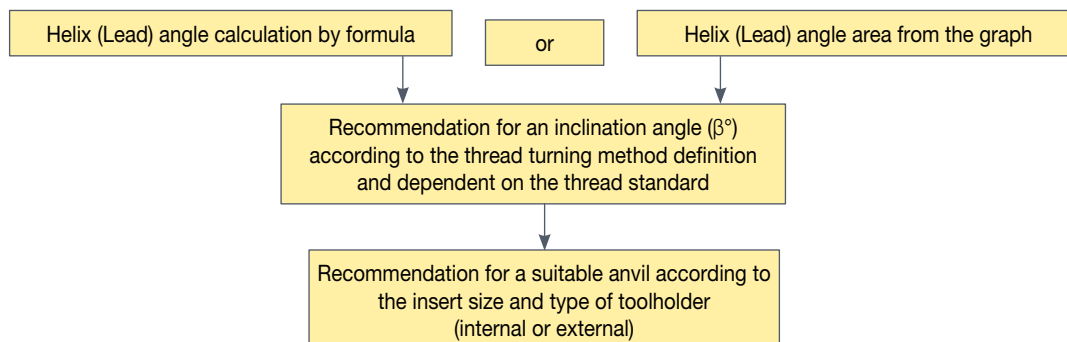

The anvil should be selected from the table according to the threading standard. The correct anvil depends on the right inclination angle (β) and insert size. The inclination angle (β) is obtained by selecting the thread turning method and finding the helix angle (ϕ) for single-start threading, or lead angle (ϕ_L) for the multi-start threading.

The helix angle (ϕ) and the lead angle (ϕ_L) are determined as exact values by using the formula below or as a graph area (see below: Helix (Lead) angle area by using graph, depending on the threading diameter and lead.

Helix angle (ϕ) calculation by using the Single-Start Threading Formula	Lead angle (ϕ_L) calculation by using the Single-Start Threading Formula
$\phi = \arctan\left(\frac{P}{\pi \times D_{pitch}}\right)$	$\phi_L = \arctan\left(\frac{Lead}{\pi \times D_{pitch}}\right)$ <p>Lead = $n \times P$</p>
When: ϕ = Helix angle Dpitch = Pitch diameter* * effective diameter of threading P = Threading pitch $\pi \approx 3.142$	When: ϕ_L = Lead angle Dpitch = Pitch diameter* * effective diameter of threading P = Threading pitch n = number of threading starts $\pi \approx 3.142$

Usable formulas

$$Lead (inch) = \frac{1 \text{ inch}}{TPI} \times \text{No. of starts}$$

$$TPI = \text{No. of threading per inch}$$

$$1 \text{ inch} = 25.4 \text{ mm}$$

$$Pitch (mm) = \frac{25.4}{TPI}$$

Helix (Lead) angle area by using graph

Helix angle evaluation

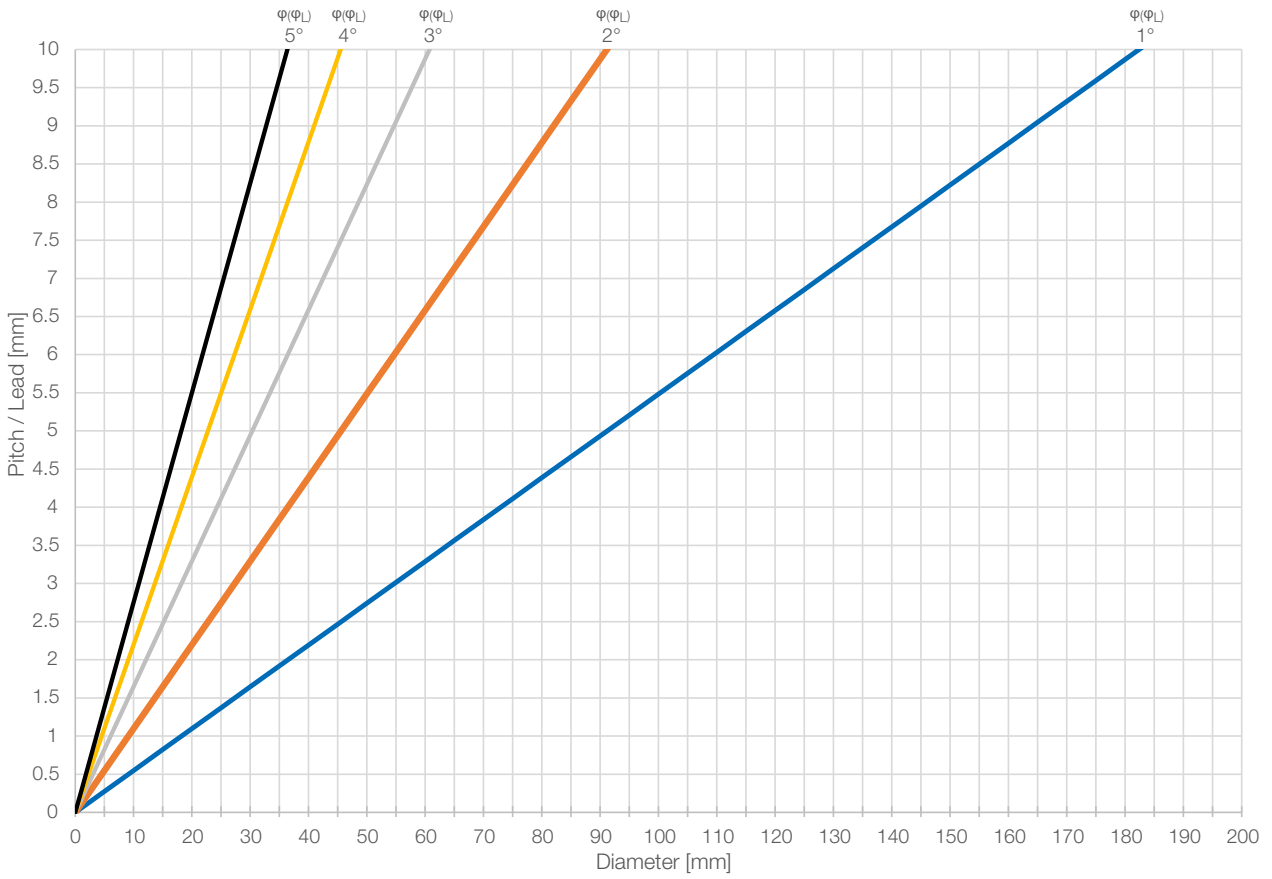

Detailed view for small pitch/diameter

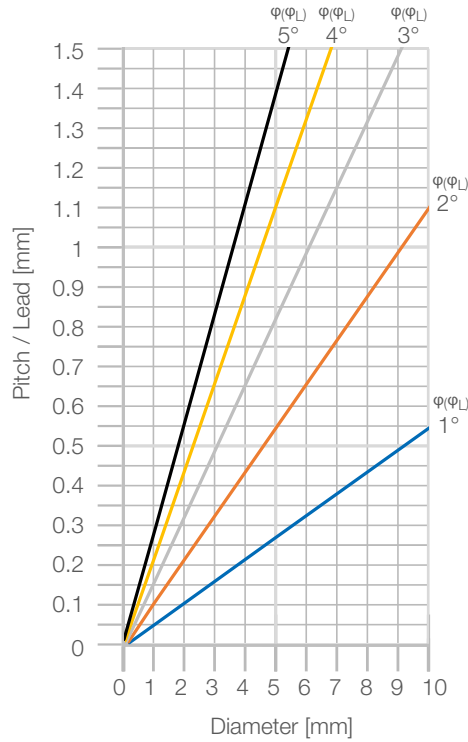

Helix (Lead) angle by using graph

Helix angle evaluation

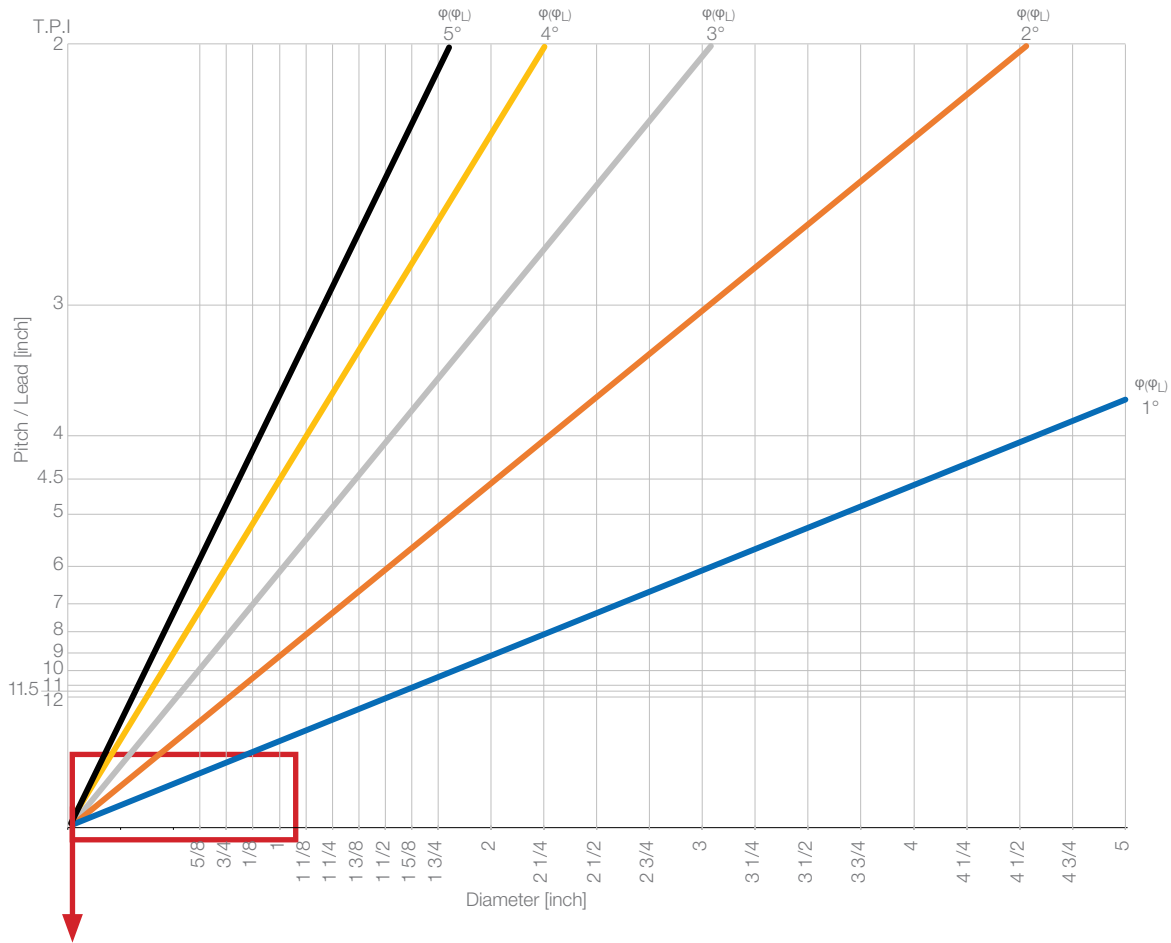

Detailed view for small pitch/diameter

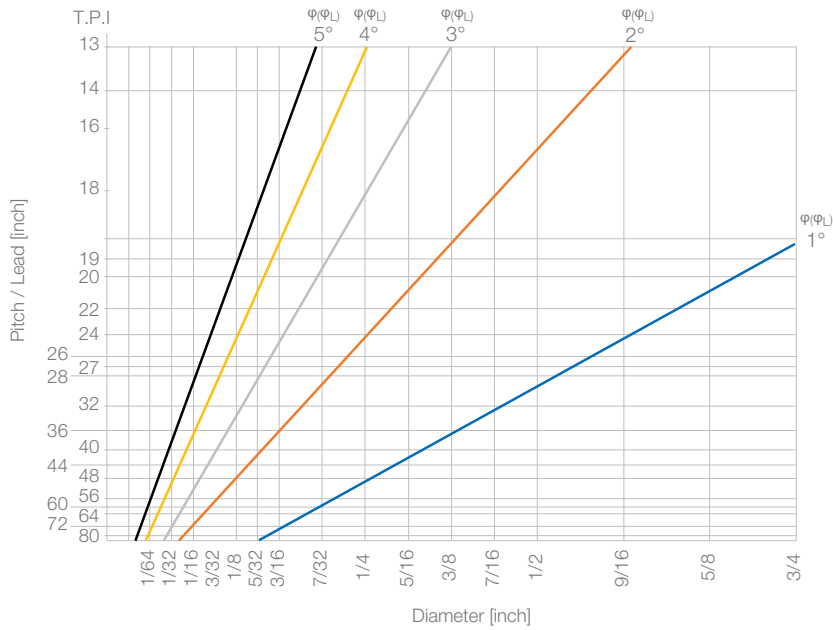

Anvil selection for symmetric threading profiles

The table below defines the recommended insert inclination angle (β) and anvil selection according to the helix angle (ϕ) for single-start threading and the lead angle (ϕ_L) for multi-start threading, depending on the threading turning method for machining the following symmetric threading profiles:

- partial profile threading with an angle profile of 60°, 55° only
- full profile threading according to ISO, UN, Whitworth, NPT, BSPT, Trapeze, ACME, RD standards only

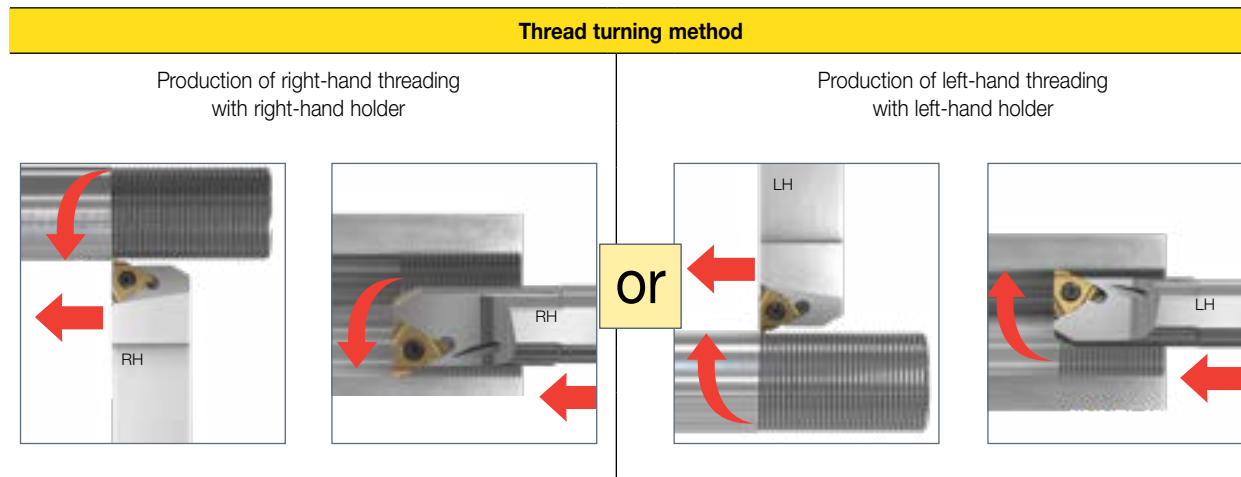

Anvil selection							
		Positive Anvils					
Threading helix (lead) angle ϕ (ϕ_L)		ϕ (ϕ_L) $\geq 5^\circ$	$4^\circ \leq \phi$ (ϕ_L) $< 5^\circ$	$3^\circ < \phi$ (ϕ_L) $\leq 4^\circ$	$2^\circ < \phi$ (ϕ_L) $\leq 3^\circ$	$1^\circ < \phi$ (ϕ_L) $\leq 2^\circ$	$0^\circ < \phi$ (ϕ_L) $\leq 1^\circ$
Inclination Angle β							
IC		Anvil Designation					
Toolholder							
16 (3/8)	EX RH OR IN LH EX RH OR IN LH	special solution	AE 16+4.5 AI 16+4.5	AE 16+3.5 AI 16-3.5	AE 16+2.5 AI 16+2.5	* AE 16+1.5 * AI 16+1.5	AE 16+0.5 AI 16+0.5
22 (1/2)	EX RH OR IN LH EX RH OR IN LH		AE 22+4.5 AI 22+4.5	AE 22+3.5 AI 22+3.5	AE 22+2.5 AI 22+2.5	* AE 22+1.5 * AI 22+1.5	AE 22+0.5 AI 22+0.5
27 (5/8)	EX RH OR IN LH EX RH OR IN LH		AE 27-4.5 AI 27+4.5	AE 27+3.5 AI 27+3.5	AE 27+2.5 AI 27+2.5	* AE 27+1.5 * AI 27+1.5	AE 27+0.5 AI 27+0.5
22U (1/2U)	EX RH OR IN LH EX RH OR IN LH		AE 22U+4.5 AI 22U+4.5	AE 22U+3.5 AI 22U+3.5	AE 22U+2.5 AI 22U+2.5	* AE 22U+1.5 * AI 22U+1.5	AE 22U+0.5 AI 22U+0.5
27U (5/8U)	EX RH OR IN LH EX RH OR IN LH		AE 27U+4.5 AI 27U+4.5	AE 27U+3.5 AI 27U+3.5	AE 27U+2.5 AI 27U+2.5	* AE 27U+1.5 * AI 27U+1.5	AE 27U+0.5 AI 27U+0.5

* Standard anvil supplied with tool

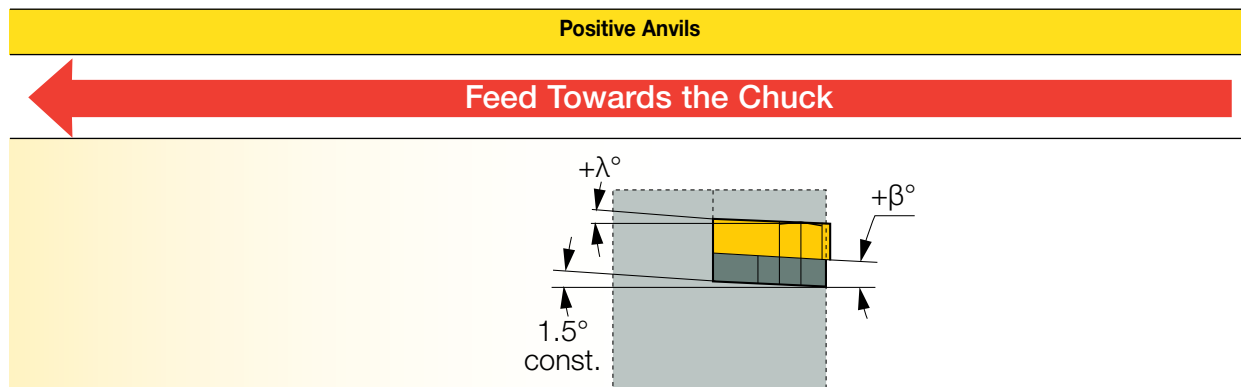

Thread turning method

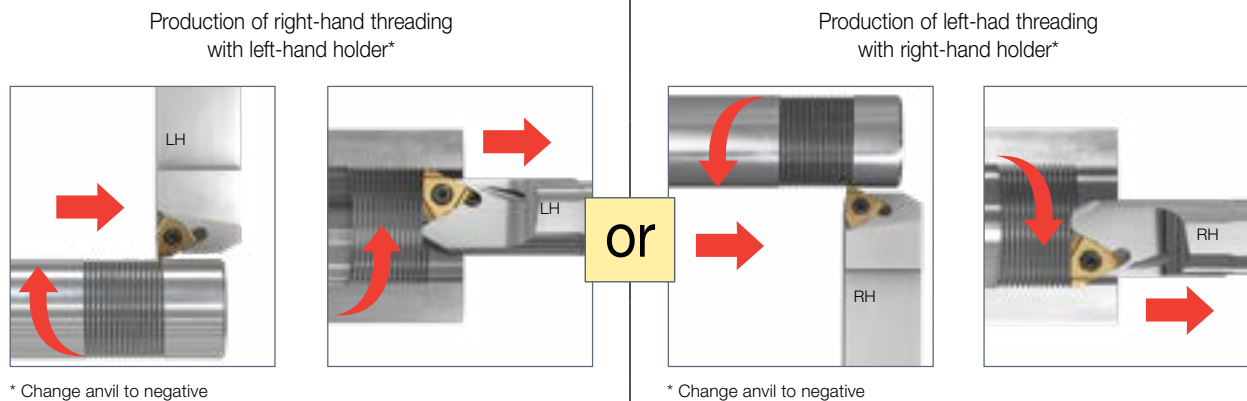

Anvil selection

		Negative Anvils		
Threading helix (lead) angle ϕ (ϕ_L)		$0^\circ < \phi$ (ϕ_L) $\leq 1^\circ$	$1^\circ < \phi$ (ϕ_L) $\leq 2^\circ$	ϕ (ϕ_L) $\geq 2^\circ$
Inclination Angle β		-0.5°	-1.5°	
IC	Toolholder	Anvil Designation		
16 (3/8)	EX RH OR IN LH EX RH OR IN LH	AE 16-0.5 AI 16-0.5	AE 16-1.5 AI 16-1.5	special solution
22 (1/2)	EX RH OR IN LH EX RH OR IN LH	AE 22-0.5 AI 22-0.5	AE 22-1.5 AI 22-1.5	
27 (5/8)	EX RH OR IN LH EX RH OR IN LH	AE 27-0.5 AI 27-0.5	AE 27-1.5 AI 27-1.5	
22U (1/2U)	EX RH OR IN LH EX RH OR IN LH	AE 22U-0.5 AI 22U-0.5	AE22U-1.5 AI 22U-1.5	
27U (5/8U)	EX RH OR IN LH EX RH OR IN LH	AE 27U-0.5 AI 27U-0.5	AE 27U-1.5 AI 27U-1.5	

- EX - Anvil for external threading
- IN - Anvil for internal threading

Negative Anvils

Feed Towards the Tailstock

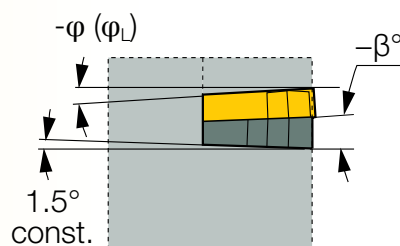

Anvil selection for ABUT threading standard only

The table below defines the recommended insert inclination angle (β) and anvil selection according to helix angle (ϕ) for single-start threading and according to lead angle (ϕ_L) for multi-start threading, depending on the threading turning method for machining asymmetric threading profile according to ABUT threading standard only.

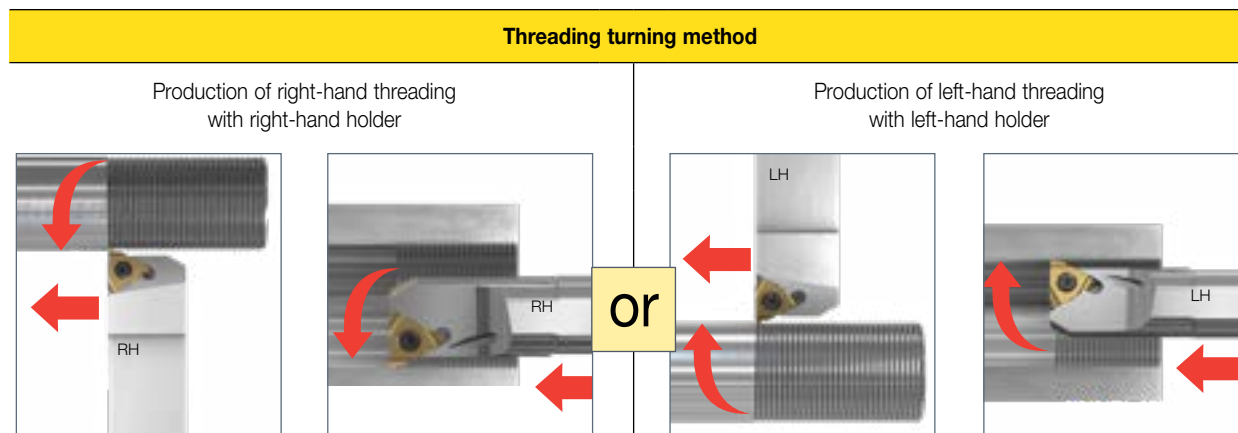

		Positive Anvils			Negative Anvils	
Threading helix (lead) angle ϕ (ϕ_L)		ϕ (ϕ_L) > 3.5°	3° < ϕ (ϕ_L) ≤ 3.5°	2° < ϕ (ϕ_L) ≤ 3°	1° < ϕ (ϕ_L) ≤ 2°	0° < ϕ (ϕ_L) ≤ 1°
Inclination angle β			1.5° (std)	0.5	-0.5°	-1.5°
IC	Toolholder	Anvil designation				
16 (3/8)	EX RH OR IN LH EX LH OR IN RH	special solution	* AE 16 +1.5 * AI 16 +1.5	AE 16 +0.5 AI 16 +0.5	AE 16 -0.5 AI 16 -0.5	AE 16 -1.5 AI 16 -1.5
22 (1/2)	EX RH OR IN LH EX LH OR IN RH		* AE 22 +1.5 * AI 22 +1.5	AE 22 +0.5 AI 22 +0.5	AE 22 -0.5 AI 22 -0.5	AE 22 -1.5 AI 22 -1.5
27 (5/8)	EX RH OR IN LH EX LH OR IN RH		* AE 27 +1.5 * AI 27 +1.5	AE 27 +0.5 AI 27 +0.5	AE 27 -0.5 AI 27 -0.5	AE 27 -1.5 AI 27 -1.5
22U (1/2U)	EX RH OR IN LH EX LH OR IN RH		* AE 22U +1.5 * AI 22U +1.5	AE 22U +0.5 AI 22U +0.5	AE 22U -0.5 AI 22U -0.5	AE 22U -1.5 AI 22U -1.5
27U (5/8U)	EX RH OR IN LH EX LH OR IN RH		* AE 27U +1.5 * AI 27U +1.5	AE 27U +0.5 AI 27U +0.5	AE 27U -0.5 AI 27U -0.5	AE 27U -1.5 AI 27U -1.5

* Standard anvil supplied with tool

- EX - Anvil for external threading
- IN - Anvil for internal threading

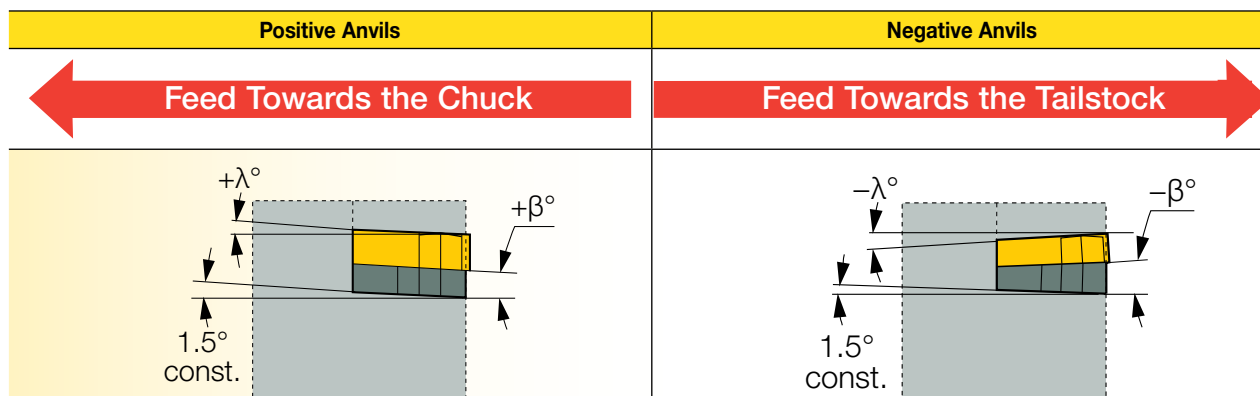

Anvil selection for SAGE threading standard only

The table below defines the recommended insert inclination angle (β) and anvil selection according to helix angle (ϕ) for single-start threading and according to lead angle (ϕ_L) for multi-start threading, depending on the thread turning method for machining asymmetric threading profile according to SAGE thread standard only.

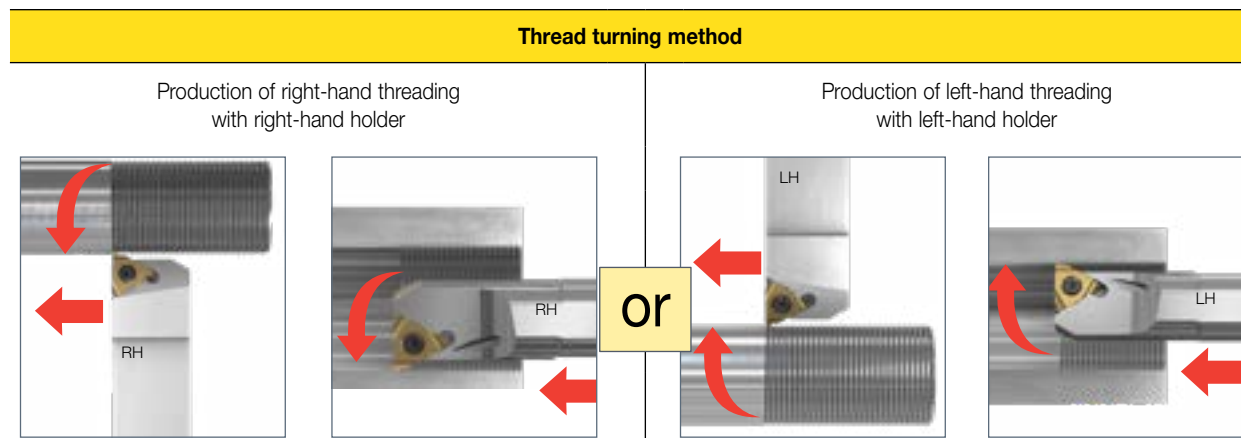

Anvil selection

		Positive Anvils			Negative Anvils		
Threading helix (lead) angle ϕ (ϕ_L)		ϕ (ϕ_L) > 5.6°	5° < ϕ (ϕ_L) ≤ 5.6°	3° < ϕ (ϕ_L) ≤ 5°	2° < ϕ (ϕ_L) ≤ 3°	1° < ϕ (ϕ_L) ≤ 2°	0° < ϕ (ϕ_L) ≤ 1°
Inclination angle β			2.5°	1.5° (std)	0.5°	-0.5°	-1.5°
IC	Toolholder	Anvil designation					
special solution	16 (3/8) EX RH OR IN LH EX RH OR IN LH	AE 16 +2.5 AI 16 +2.5	* AE 16 +1.5 * AI 16 +1.5	AE 16 +0.5 AI 16 +0.5	AE 16 -0.5 AI 16 -0.5	AE 16 -1.5 AI 16 -1.5	
	22 (1/2) EX RH OR IN LH EX RH OR IN LH	AE 22 +2.5 AI 22 +2.5	* AE 22 +1.5 * AI 22 +1.5	AE 22 +0.5 AI 22 +0.5	AE 22 -0.5 AI 22 -0.5	AE 22 -1.5 AI 22 -1.5	
	27 (5/8) EX RH OR IN LH EX RH OR IN LH	AE 27 +2.5 AI 27 +2.5	* AE 27 +1.5 * AI 27 +1.5	AE 27 +0.5 AI 27 +0.5	AE 27 -0.5 AI 27 -0.5	AE 27 -1.5 AI 27 -1.5	
	22U (1/2U) EX RH OR IN LH EX RH OR IN LH	AE 22U +2.5 AI 22U +2.5	* AE 22U +1.5 * AI 22U +1.5	AE 22U +0.5 AI 22U +0.5	AE 22U -0.5 AI 22U -0.5	AE 22U -1.5 AI 22U -1.5	
	27U (5/8U) EX RH OR IN LH EX RH OR IN LH	AE 27U +2.5 AI 27U +2.5	* AE 27U +1.5 * AI 27U +1.5	AE 27U +0.5 AI 27U +0.5	AE 27U -0.5 AI 27U -0.5	AE 27U -1.5 AI 27U -1.5	

* Standard anvil supplied with tool

- EX - Anvil for external threading
- IN - Anvil for internal threading

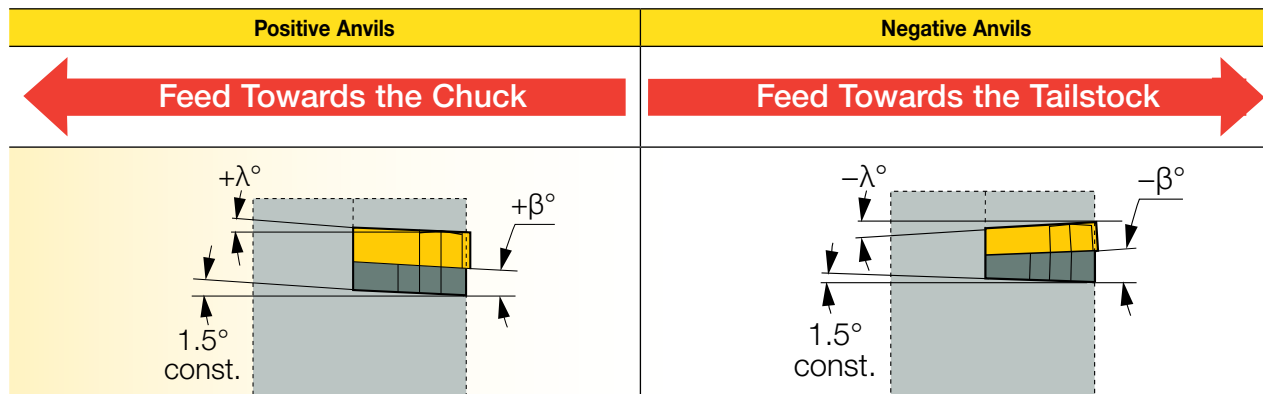

Mini-Tool Features

(1)	øD M8; 5/16"-UN; 1/16"-NPT	
(2)	4H÷8H/1B÷3B	
(3)	A	0.00

- (1) Smallest possible thread
- (2) All tolerances
- (3) Minimum runout
- (4) High surface quality

Flank Clearance and Effective Inclination Angle

Inclination angle β of the cutting edges corresponds to a specific thread helix angle λ and ensures an equal clearance angle on both sides of the insert.

$\alpha_l = \alpha_r$	Incorrect $\alpha_l < \alpha_r$
α - Flank clearance angle λ - Helix angle β - Effective inclination angle is achieved by selecting the suitable anvil	H - Depth of thread profile (on \emptyset) D - Depth of pass (on \emptyset) U - Depth of finishing pass (on \emptyset)

Infeed Methods for Threading Operations

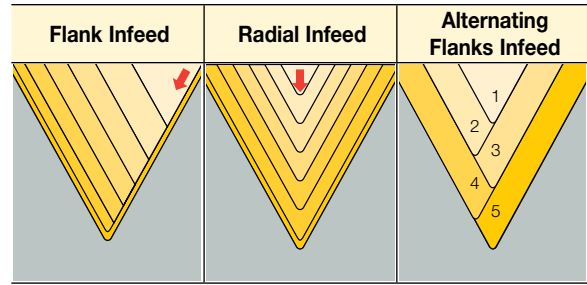

Flank Equal

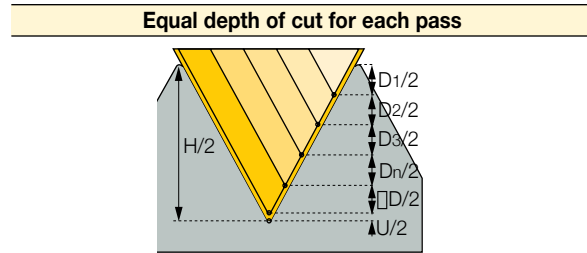

$$\frac{D_1}{2} = \frac{D_2}{2} = \frac{D_3}{2} = \frac{D_n}{2}$$

Diminished depth of cut for each pass

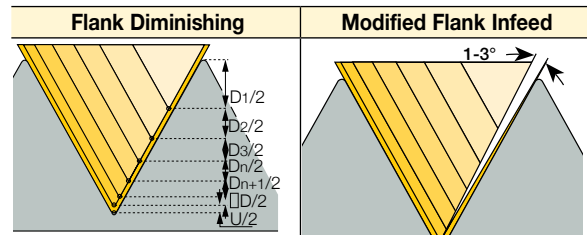

$$\frac{D_1}{2} > \frac{D_2}{2} > \frac{D_3}{2} > \frac{D_n}{2} > \frac{D_{n+1}}{2}$$

Depth per Pass and Number of Passes

In order to produce threads, the cutting tool needs to make several numbers of cuts along the workpiece surface. The parameters of depth per pass and number of passes have a very important role in threading production. These parameters have a direct effect on cutting edge wear, tool life, threading surface quality, and threading production stability.

The two methods most common in determining the depth per pass and the number of passes are constant chip area by decreasing depth per pass or constant depth per pass. The choice of method does not depend on the selected infeed methods (radial infeed, flank infeed, modified flank infeed, alternating flank infeed), which are described in chapter 2.12.

The depth per pass and number of passes parameters depend on the type of equipment, tool overhang, machine stability, workpiece material, cutter geometry and the threading depth required.

Constant chip area by decreasing depth per pass (recommended)

This is the most common method and is generally recommended, as in most cases it ensures high productivity. The principle of this method is that the initial cutting depth at the first pass is the largest, and then gradually decreases at each pass to ensure material removal within a constant chip area.

The calculation of passes is designed so that the last pass, which is destined to be a finish pass, will be 0.05 - 0.1 mm (0.0019 - 0.0039 inches). Using this method ensures constant loads on cutting edge and uniform wear, which increases tool life.

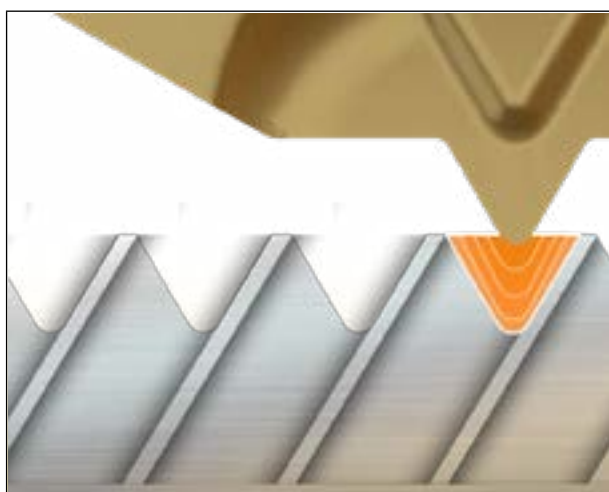

Formula for calculation of depth per pass

$$\Delta a_{p(i)} = \frac{a_p}{\sqrt{n_a - 1}} \times \sqrt{C}$$

When:

$\Delta a_{p(i)}$ — Depth of cut i pass ($i = 1 \dots n_a$)

i — Pass

a_p — Total depth of cut

n_a — Number of passes

C — Constant value:
For 1st pass: $C=0.3$; For 2nd pass: $C=1$; For 3rd pass and higher: $C = i - 1$

Threading Limits with Standard NOTCH-GRIP Inserts

The following charts list the largest pitch 6.

60° V-Threading Limits

FLT-2 Inserts Threads Per Inch	Internal Threading Limitations		
	Nominal Thread Size	Minimum Minor Diameter	
		Inch	MM
6	1-7/8	1.695	43.05
7	1-3/4	1.595	40.51
8	1-5/8	1.490	37.85
9	1-9/16	1.442	36.63
10	1-1/2	1.392	35.36
11	1-7/16	1.339	34.01
12	1-3/8	1.285	32.64
13	1-5/16	1.229	31.22
14	1-1/4	1.173	29.79
16	1-1/4	1.182	30.02
18	1-1/8	1.065	27.05
20	1-1/8	1.071	27.20
24	1-1/16	1.017	25.83

* 24 TPI and finer can be cut with a #2 series insert provided that the minor diameter is 1.000 or larger.

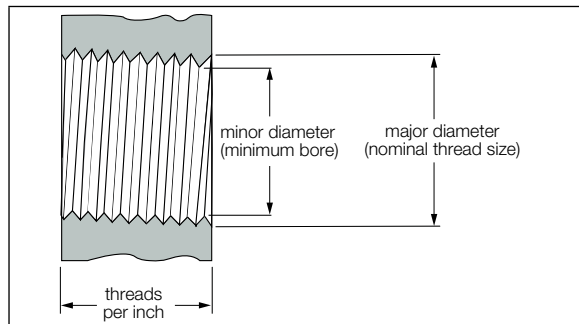

FLT-3 & 4 Inserts Threads Per Inch	Internal Threading Limitations		
	Nominal Thread Size	Minimum Minor Diameter	
		Inch	MM
4**	3	2.729	69.32
4-1/2**	2-7/8	2.634	66.90
5	2-3/4	2.534	64.36
6	2-1/2	2.320	58.93
7	2-1/4	2.095	53.21
8	2	1.865	47.37
9	1-15/16	1.817	46.15
10	1-7/8	1.767	44.88
11	1-13/16	1.714	43.54
12	1-3/4	1.660	42.16
13	1-5/8	1.542	39.17
14	1-9/16	1.485	37.72
16*	1-7/16	1.370	34.80

* 16 pitch acme threads and finer can be cut provided the minor diameter is 1.370 or larger.

** FLT-4 only.

Acme Threading Limits

FLA-2 Threads Per Inch	Internal Threading Limitations		
	Nominal Thread Size	Minimum Minor Diameter	
		Inch	MM
6	2-1/2	2.333	59.26
8	2-1/4	2.125	53.98
10	2	1.900	48.26
12	1-3/4	1.667	42.34
14	1-5/8	1.554	39.47
16*	1-1/2	1.438	36.53

* 16 pitch acme threads and finer can be cut provided the minor diameter is 1.438 or larger.

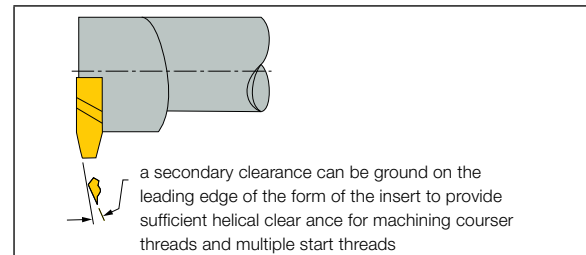

Modified standard inserts may be produced for special threads or ones not listed on the charts shown. quoted upon request.

FLA-3, 4 & 6 Threads Per Inch	Internal Threading Limitations		
	Nominal Thread Size	Minimum Minor Diameter	
		Inch	MM
2*	5	4.500	114.30
2-1/2**	4-1/2	4.100	104.14
3**	4	3.665	93.09
4	3-1/2	3.250	82.55
5	3	2.800	71.12
6	2-1/2	2.333	59.26
8	2-1/4	2.125	53.98
10	2	1.900	48.26
12	1-3/4	1.667	42.34
14	1-5/8	1.554	39.47
16*	1-1/2	1.438	36.53

* 16 pitch acme threads and finer can be cut provided the minor diameter is 1.438 or larger.

** FLA-6 only.

Note: positive rake ACME inserts are recommended for stainless steels and high-temp alloy applications. Quoted upon request.

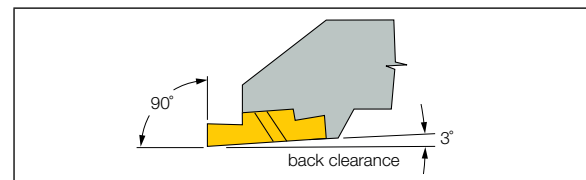

Note: tool holders are designed to locate the insert at a 3° angle to provide back clearance down the side.

FLT B-2A & 2B Internal Threading Limitations			
Threads Per Inch	Nominal Thread Size	Minimum Minor Diameter	
		Inch	MM
8	1-3/4	1.600	40.64
10	1-5/8	1.505	38.23
12	1-1/2	1.400	35.56
16	1-1/4	1.175	29.85
20	1-1/16	1.002	25.45

FLT B-3A & 4A Internal Threading Limitations			
Threads Per Inch	Nominal Thread Size	Minimum Minor Diameter	
		Inch	MM
4*	2-1/2	2.200	55.88
5	2-1/4	2.010	51.05
6	2	1.800	45.72
8	1-3/4	1.600	40.64
10	1-5/8	1.505	38.23
12**	1-1/2	1.400	35.56

* FLT B-4A insert only

** 16 or 20 threads per inch can be cut providing minor diameter is 1.375 or larger.

FLT B-3B & 4B Internal Threading Limitations			
Threads Per Inch	Nominal Thread Size	Minimum Minor Diameter	
		Inch	MM
4	*2-7/8	2.575	65.41
5	2-3/4	2.510	63.75
6	2-3/8	1.175	29.85
8	2-1/8	1.975	50.17
10	1-7/8	1.755	44.58
12	1-5/8	1.525	38.74
16	1-1/2	1.407	35.74
20	1-7/16	1.378	35.00

* FLT B-4B insert only

American Standard Buttress Thread Designations

When only the designation BUTT is used, the thread is a "pull" type buttress (external thread pulls) with the clearance flank (45°) leading and the pressure flank (7°) following.

When the designation PUSH-BUTT is used, the thread is a push type buttress (external thread pushes) with the load flank (7°) leading and the 45° clearance flank following.

Whenever possible this description should be confirmed by a simplified view showing thread angles on the drawing of the product that has the buttress thread.

Always remember that the position of your holder and direction of your feed will determine the lead angle on the insert.

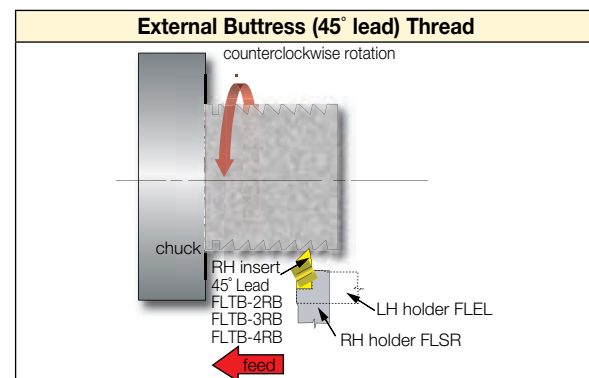

45° clearance angle of this buttress thread becomes the leading angle in this application.

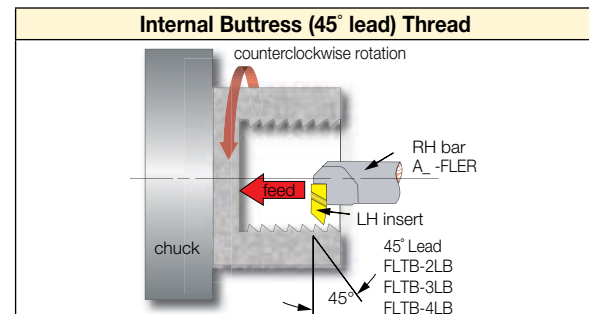

45° clearance flank of this buttress thread becomes the leading angle in this application.

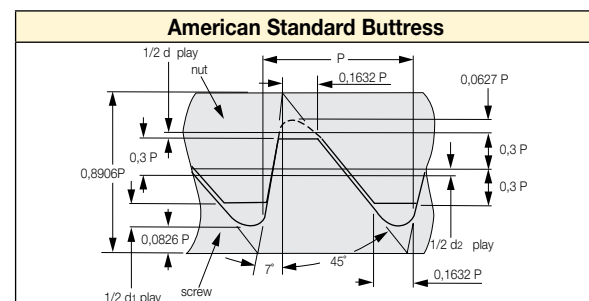

Use: fittings and pipe couplings

Cutting Data

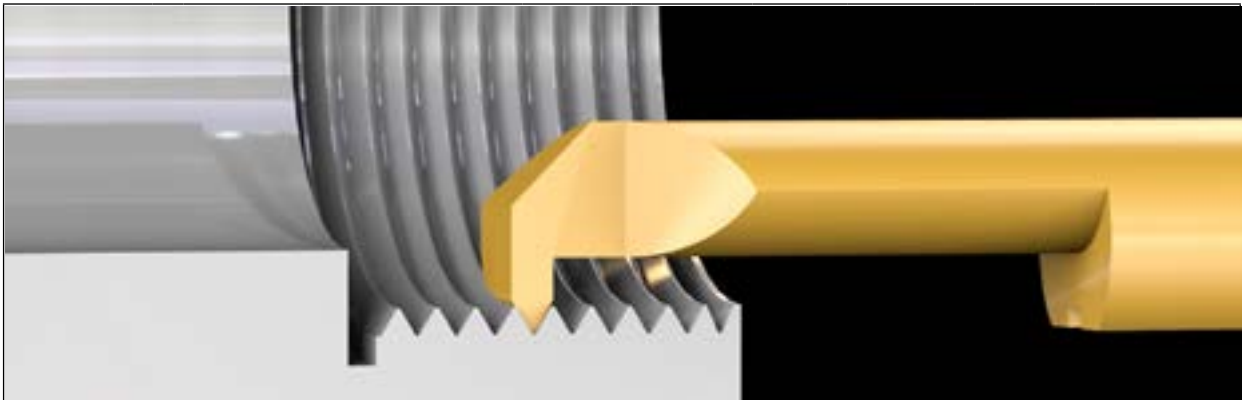









Carbide Grade		Steel (N/mm Tensile Strength)					Stainless Steel	Cast Iron	Non-ferrous
		400-500	500-700	700-850	850-1150	>1150			
Cutting Speed V _c (m/min)	IC228	160	140	120	90	70	90	100	300
	IC908	185	160	140	105	80	105	115	350
Pitch (p) mm	TPI	No. of Passes							
0.5	48	6	6	7	7	8	8	7	6
0.75	32	8	8	9	9	10	10	9	8
1.0	24	10	10	12	12	12	12	12	10
1.25	20-19	12	12	14	14	15	15	14	12
1.5	16	15	15	17	17	18	18	17	15

For internal threading of small diameters, the PVD coated grade IC228 is recommended.

Material groups	ISO P		ISO M	ISO K	ISO N	ISO S	ISO H
	1-11	12-13	14	15-20	21-28	31-37	38-41
	Steel	Stainless Steel Ferritic & Martensitic	Stainless Steel Austenitic & Duplex (Ferritic-Austenitic)	Cast Iron	Non-ferrous	High Temperature Alloys	Hard Steel & Cast Iron
	IC1007	IC1007	IC1007	IC1007	IC08	IC806	IC1007
	IC808 (IC908)			IC808 (IC908)		IC1007	
	IC250 (IC950)	IC808 (IC908)	IC808 (IC908)	IC250 (IC950)	IC228	IC808 (IC908)	IC808 (IC908)
	IC228	IC228	IC228	IC228	IC28		

■ First choice

Troubleshooting

		Cause	Solution
Plastic Deformation		<ul style="list-style-type: none"> Excessive heat in cutting zone Wrong carbide grade Inadequate coolant supply Depth of cut too large Cutting speed too high Nose radius too small 	<ul style="list-style-type: none"> Reduce RPM / Reduce depth of cut / Check turned dia. Use coated grade / Use harder grade Apply coolant Reduce depth of cut / Increase no. of passes Reduce cutting speed If possible use insert with larger radius
Premature Wear		<ul style="list-style-type: none"> Cutting speed too high Infeed depth too small Highly abrasive material Inadequate coolant supply Wrong inclination anvil Wrong turned dia. prior to threading Insert is above center line 	<ul style="list-style-type: none"> Reduce RPM Modify flank infeed / Increase depth of cut Use coated grade Apply coolant Reselect anvil Check turned dia. Check center height
Insert Breakage		<ul style="list-style-type: none"> Wrong turned dia. prior to threading Wrong grade Poor chip control Incorrect center height 	<ul style="list-style-type: none"> Check turned dia. Use tougher grade Change to M-Type / B-Type inserts and use modified flank infeed Check center height
Build Up Edge		<ul style="list-style-type: none"> Cutting edge too cold Wrong grade Inadequate coolant supply Incorrect cutting speed 	<ul style="list-style-type: none"> Increase RPM / Increase depth of cut Use coated grade Apply coolant Increase cutting speed
Vibration		<ul style="list-style-type: none"> Incorrect workpiece clamping Incorrect tool setup Incorrect cutting speed Incorrect center height 	<ul style="list-style-type: none"> Use soft jaws Check tool overhang / Use anti-vibration bars Increase cutting speed Check center height
Incorrect Thread Profile		<ul style="list-style-type: none"> Unsuitable threading profile Incorrect center height Incorrect pitch in the program 	<ul style="list-style-type: none"> Adjust to correct tool, anvil, and insert Adjust center height Change the program
Broken Nose During 1st Pass		<ul style="list-style-type: none"> Cutting edge too cold Depth of cut too large Wrong grade Wrong turned dia. prior to threading Incorrect center height Infeed depth too shallow Wrong inclination anvil Tool overhang tool long 	<ul style="list-style-type: none"> Reduce RPM Reduce depth of cut/Increase number of infeed passes Use tougher grade Check turned dia. Adjust center height Change depth of cut Reselect anvil Reduce tool overhang / Use Anti-vibration bar
Poor Surface Finish		<ul style="list-style-type: none"> Wrong cutting speed Excessive heat in cutting zone Poor chip control Inadequate coolant supply Wrong inclination anvil Tool overhang too long Incorrect center height 	<ul style="list-style-type: none"> Increase/reduce RPM Reduce depth of cut Modify flank infeed Apply coolant Reselect anvil Reduce tool overhang Check center height
Poor Chip Control		<ul style="list-style-type: none"> Excessive heat in cutting zone Wrong grade Inadequate coolant supply Wrong turned dia. prior to threading Incorrect method of infeed 	<ul style="list-style-type: none"> Reduce RPM /change depth of cut /check turned dia. Use coated grade /check turned dia./use M/B-Type inserts Apply coolant Check turned dia. Modify flank infeed 3-5°

Special Request Form Thread Turning

Project Information Customer _____ Industry _____ Country _____

Customer Goal (Productivity, Economy, etc.): _____

Proposal for: Finish Insert Rough Insert Holder Machining Concept

ISCAR Representative: _____ Email: _____ Tel: _____

Competitors: _____ Target Price: _____ Annual Consumption: _____

Threading Designation _____ Pitch _____ Standard _____ Tolerance Clas _____

Major Dia. _____ Minor Dia. _____ Pitch Dia. _____ Number of Starts _____

Threading Depth _____ Through Hole Blind Hole

Special Form _____

For non-standard profiles, detailed information must be supplied (drawing, dimensions & tolerances)

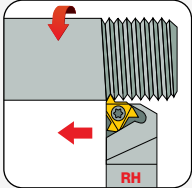
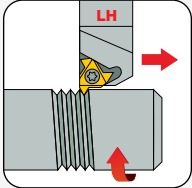
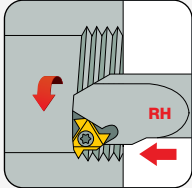
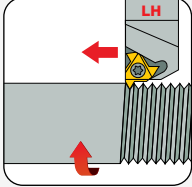
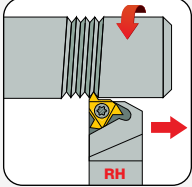
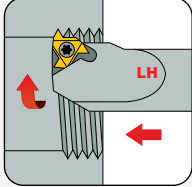
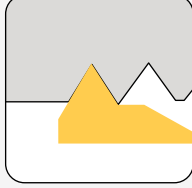
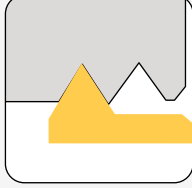
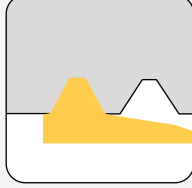
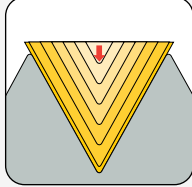
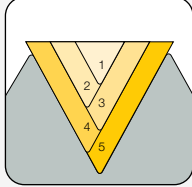
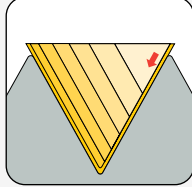
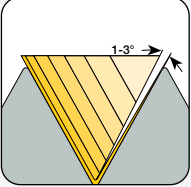
Application	Part _____	Material _____	Hardness _____
RH Right-hand Threading	<input type="checkbox"/> 	<input type="checkbox"/> 	<input type="checkbox"/> 
LH Left-hand Threading	<input type="checkbox"/> 	<input type="checkbox"/> 	<input type="checkbox"/> 
Insert Profile:	<input type="checkbox"/> Full 	<input type="checkbox"/> Partial 	<input type="checkbox"/> Semi-Partial 
Infeed:	<input type="checkbox"/> Radial 	<input type="checkbox"/> Incremental 	<input type="checkbox"/> Flank 
			<input type="checkbox"/> Modified Flank 

Attachments Drawing Model Sketch Photo

Machine Model _____ Shank Type/Size _____

Coolant: Internal External None Type: _____

Remarks: _____

NON-ROTATING HOLDERS

YOU

INTELLIGENTLY?

TURNING



CONTENTS

HOLDERS FOR SQUARE AND ROUND SHANK TOOLS	829
CAMFIX Shanks.....	829
HSK Shanks	835
Cylindrical Shanks	845
MODULAR-GRIP ADAPTATIONS	849
Toolholder Systems for Multi-Spindle Machines	852
Toolholder Systems for Turning Lathes	862
Intermediate Holders for Square Type Adapters (TGAQ/DGAQ)	881
TOOL BLOCKS	689
EXCHANGEABLE HEAD HOLDERS	693

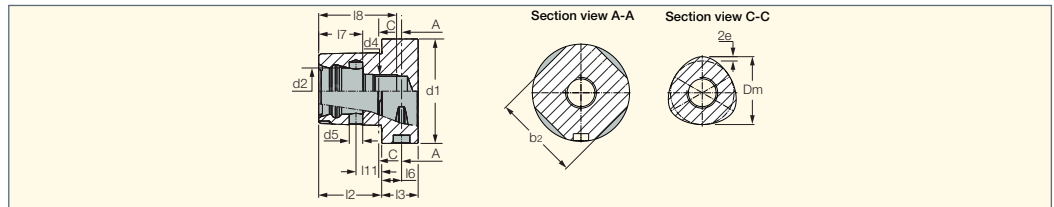

CAMFIX	b2	d1 ±0.1	d2	d4	d5 ±0.1	Dm	e	l1	l2 ±0.1	l3 min	l6 ±0.15	l7 ±0.15	l8 min	l11 ±0.1
C3	28.3	32	15	M12x1.5	3.6	22	0.7	2.5	19	15	6	13	25	8
C4	35.3	40	18	M14x1.5	4.6	28	0.9	2.5	24	20	8	15	30	8
C5	44.4	50	21	M16x1.5	6.1	35	1.12	3	30	20	10	20	37	14
C6	55.8	63	28	M20x2	8.1	44	1.4	3	38	22	12	27	47	15.5
C8	71.1	80	32	M20x2	9.1	55	2	3	48	30	12	28	48	25
C8X	88.7	100	32	M20x2	9.1	55	2	3	48	32	16	28	48	25
C10	88.3	100	43	M20x2	12	72	2.8	3	60	36	16	40	70	26.5

CAMFIX - ISO 26623-1
Standard Quick Change
Shanks

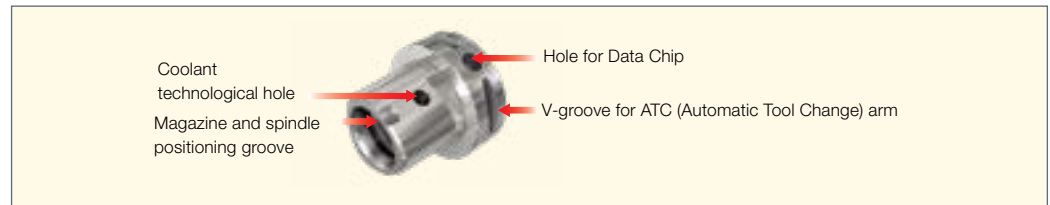

Features

- **Symmetrical design:** Due to the symmetrical design, the torque load is distributed on the polygon, providing a self-centering effect.
- **Rigidity:** The **CAMFIX** clamping mechanism is extremely rigid to counter bending forces.
- **Accuracy:** The taper and face contact ensure high repeatability within 2 microns, when operated with an automatic tool changer.

CAMFIX

C#-ASHR/L
 Holders with CAMFIX
 Exchangeable Shanks for
 External Square Shank Tools

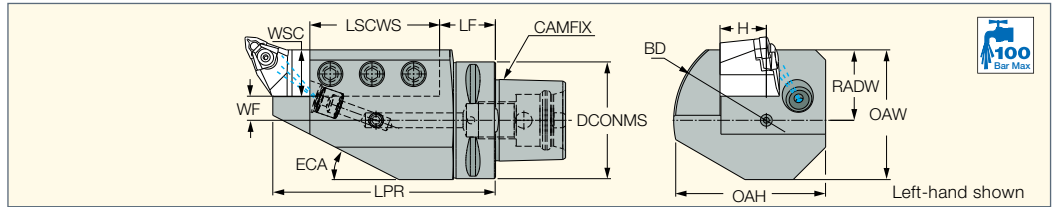

Designation	DCONMS	H	WSC	WF	LPR	LSCWS	LF	OAH	RADW	OAW	ECA	BD	DCP ⁽²⁾
C4 ASHR/L 16-1	40.00	16.0	16.0	7.00	104.00	70.00	34.00	50.00	23.0	43.50	30.0	60.00	1
C5 ASHR/L 20-1	50.00	20.0	20.0	10.00	98.00	63.50	24.50	78.00	30.0	59.00	30.0	90.00	1
C6 ASHR/L 20-1	63.00	20.0	20.0	10.00	100.00	63.50	26.50	78.00	30.0	59.00	30.0	90.00	1
C6 ASHR/L 25-1	63.00	25.0	25.0	13.00	120.00	70.00	30.00	82.00	38.0	70.00	27.0	100.00	1
C6 ASHR 25 1-J ⁽¹⁾	63.00	25.0	25.0	4.50	120.00	82.00	38.00	86.50	29.5	61.00	4.1	90.00	1
C8 ASHR/L 32-1	80.00	32.0	32.0	8.00	140.00	90.00	40.00	87.00	40.0	80.00	27.0	110.00	1

⁽¹⁾ Recommended for Mazak INTEGREX! No interference problem on machine magazine
⁽²⁾ 1 - Slot for data chip, 0 - Without slot for data chip

Spare Parts

Designation						
C4 ASHR/L 16-1	SR M8X16 DIN915	HW 5.0*	SATZ-M10X1-M5	COOLING TUBE C4*	WRENCH NOZZLE HP M10*	WRENCH COOL TUBE C4*
C5 ASHR/L 20-1	SR M10X25 DIN915	HW 5.0*	SATZ-M10X1-M5	COOLING TUBE C5*	WRENCH NOZZLE HP M10*	WRENCH COOL TUBE C5*
C6 ASHR/L 20-1	SR M10X25 DIN915	HW 5.0*	SATZ-M10X1-M5	COOLING TUBE C6*	WRENCH NOZZLE HP M10*	WRENCH COOL TUBE C6*
C6 ASHR/L 25-1	SR M12X30 DIN915	HW 6.0*	SATZ-M12X1-M6	COOLING TUBE C6*	WRENCH NOZZLE HP M12*	WRENCH COOL TUBE C6*
C8 ASHR/L 32-1	SR M12X30 DIN915	HW 6.0*	SATZ-M12X1-M6	COOLING TUBE C8*	WRENCH NOZZLE HP M12*	WRENCH COOL TUBE C8*

* Optional, to be ordered separately

CAMFIX

C#-ASHA
 Perpendicular Holders with
 CAMFIX Shanks for External
 Square Shank Tools

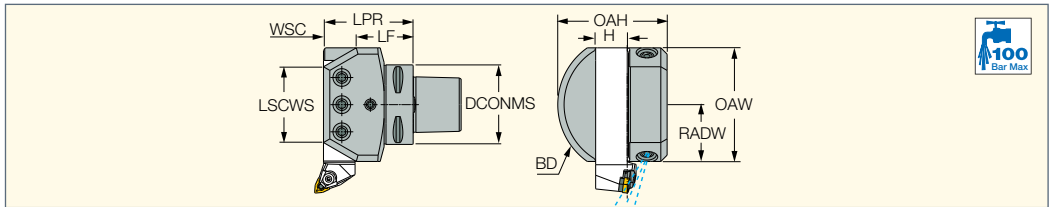

Designation	DCONMS	H	WSC	LPR	LSCWS	LF	RADW	OAW	OAH	BD	DCP ⁽¹⁾
C5 ASHA 20	50.00	20.0	20.0	58.00	46.00	38.00	38.0	76.00	76.5	90.00	1
C6 ASHA 20	63.00	20.0	20.0	60.00	46.00	40.00	38.0	76.00	76.5	90.00	1
C6 ASHA 25	63.00	25.0	25.0	71.00	61.00	46.00	45.0	90.00	86.6	110.00	1
C8 ASHA 32	80.00	32.0	32.0	85.00	80.00	53.00	55.0	110.00	95.0	142.00	1

⁽¹⁾ 1 - Slot for data chip, 0 - Without slot for data chip

Spare Parts

Designation						
C5 ASHA 20	SR M10X25 DIN915	HW 5.0*	SATZ-M10X1-M5	WRENCH NOZZLE HP M10*	COOLING TUBE C5*	WRENCH COOL TUBE C5*
C6 ASHA 20	SR M10X25 DIN915	HW 5.0*	SATZ-M10X1-M5	WRENCH NOZZLE HP M10*	COOLING TUBE C6*	WRENCH COOL TUBE C6*
C6 ASHA 25	SR M12X30 DIN915	HW 6.0*	SATZ-M12X1-M6	WRENCH NOZZLE HP M12*	COOLING TUBE C6*	WRENCH COOL TUBE C6*
C8 ASHA 32	SR M12X30 DIN915	HW 6.0*	SATZ-M12X1-M6	WRENCH NOZZLE HP M12*	COOLING TUBE C8*	WRENCH COOL TUBE C8*

* Optional, to be ordered separately

CAMFIX

C#-ADE

Holders with CAMFIX
Exchangeable Shanks for
External Square Shank Tools

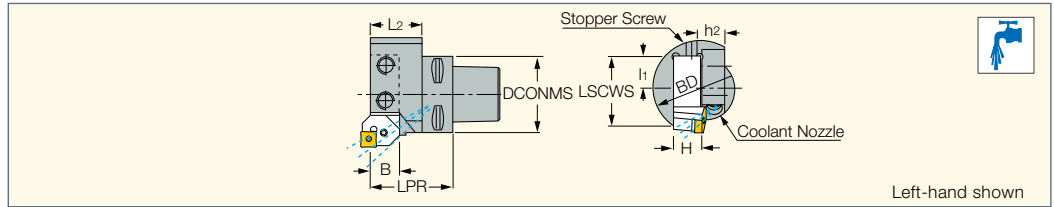

Left-hand shown







Designation	DCONMS	LPR	L2	B	BD	LSCWS	i1	H	h2	CP ⁽¹⁾	DCP ⁽²⁾
C3 ADE 16R/L	32.00	45.00	28.10	16.0	65.00	45.0	20.00	16.0	20.0	100	0
C4 ADE-20L	40.00	49.20	29.10	20.0	87.00	57.0	32.00	20.0	26.0	100	1
C4 ADE-20R	40.00	49.20	27.30	20.0	87.00	57.0	32.00	20.0	26.0	100	1
C5 ADE-20R/L	50.00	55.20	35.10	20.0	87.00	57.0	32.00	20.0	26.0	100	1

- Use the tools with AD suffix
- Regular tools should be shortened

⁽¹⁾ Coolant pressure (Bar)

⁽²⁾ 1 - Slot for data chip, 0 - Without slot for data chip

Spare Parts

Designation							
C3 ADE 16R/L	SR M10X20 DIN915	HW 3.0*	SR M6X8 DIN916 ^(a)	HW 5.0*			
C4 ADE-20L	SR M10X16DIN912	HW 4.0*	SR M8X10 DIN913 ^(a)	HW 8.0*	COOLING TUBE C4*	WRENCH COOL TUBE C4*	SATZ-M10X1-M5
C4 ADE-20R	SR M10X16DIN912		SR M8X10 DIN913 ^(a)	HW 8.0*	COOLING TUBE C4*	WRENCH COOL TUBE C4*	SATZ-M10X1-M5
C5 ADE-20L		HW 4.0	SR M8X10 DIN916 ^(a)	HW 8.0*	COOLING TUBE C5*	WRENCH COOL TUBE C5*	EZ 125
C5 ADE-20R			SR M8X10 DIN916 ^(a)		COOLING TUBE C5*	WRENCH COOL TUBE C5*	SATZ-M10X1-M5

* Optional, to be ordered separately

^(a) Stopper screw

CAMFIX

C#-ASHR/L-45



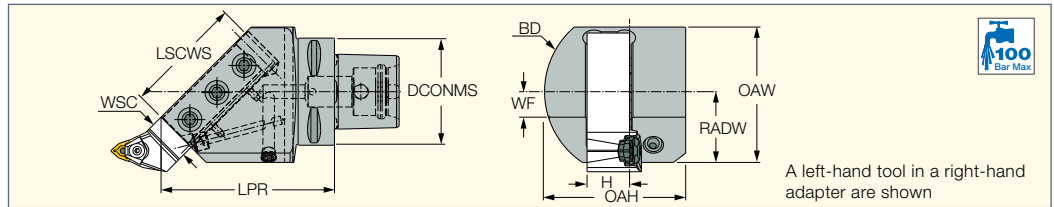



Holders with CAMFIX
Exchangeable Shanks Carrying
Square Shank Tools for 45°
Mounting on Turn-Mill Machines



Designation	DCONMS	H	WSC	WF	LPR	LSCWS	OAH	RADW	OAW	BD	DCP ⁽¹⁾
C5 ASHR/L 20-45	50.00	20.0	20.0	15.00	96.30	-	62.00	36.0	67.50	72.00	1
C6 ASHR/L 20-45	63.00	20.0	20.0	15.00	98.30	-	62.00	36.0	67.50	72.00	1
C6 ASHR/L 25-45	63.00	25.0	25.0	15.00	102.00	70.00	83.00	41.6	79.60	100.00	1
C8 ASHR/L 32-45	80.00	32.0	32.0	17.00	140.00	100.00	110.00	50.0	110.00	140.00	1

⁽¹⁾ 1 - Slot for data chip, 0 - Without slot for data chip

Spare Parts

Designation						
C5 ASHR/L 20-45	SR M10X25 DIN915	HW 5.0*	SATZ-M10X1-M5	WRENCH NOZZLE HP M10*	COOLING TUBE C5*	WRENCH COOL TUBE C5*
C6 ASHR/L 20-45	SR M10X25 DIN915	HW 5.0*	SATZ-M10X1-M5	WRENCH NOZZLE HP M10*	COOLING TUBE C6*	WRENCH COOL TUBE C6*
C6 ASHR/L 25-45	SR M12X30 DIN915	HW 6.0*	SATZ-M10X1-M5	WRENCH NOZZLE HP M10*	COOLING TUBE C6*	WRENCH COOL TUBE C6*
C8 ASHR/L 32-45	SR M12X30 DIN915	HW 6.0*	SATZ-M12X1-M6	WRENCH NOZZLE HP M12*	COOLING TUBE C8*	WRENCH COOL TUBE C8*

* Optional, to be ordered separately

CAMFIX

C#-ADES

Holders with CAMFIX
Exchangeable Shanks for
External Square Shank Tools

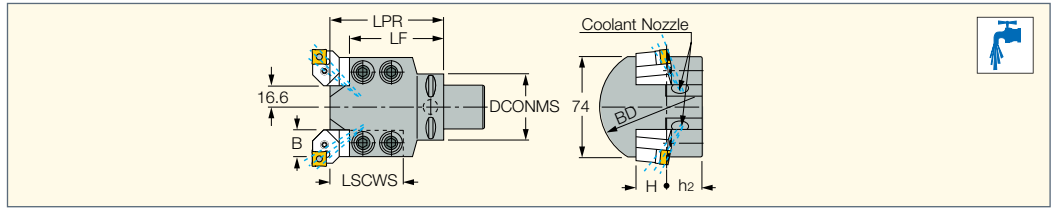

Designation	DCONMS	LPR	LSCWS	LF	B	BD	H	h2	DCP ⁽¹⁾
C4 ADES-20	40.00	85.00	54.00	71.00	20.0	90.00	20.0	26.0	1
C5 ADES-20	50.00	85.00	54.00	71.00	20.0	90.00	20.0	26.0	1

• Use the tools with AD suffix. Regular tools should be shortened.

⁽¹⁾ 1 - Slot for data chip, 0 - Without slot for data chip

Spare Parts

Designation					
C4 ADES-20		SR M8X6 DIN913		SATZ-M10X1-M5	COOLING TUBE C4*
C5 ADES-20	SR M10X16DIN912	SR M8X6 DIN913		SATZ-M10X1-M5	COOLING TUBE C5*

* Optional, to be ordered separately

CAMFIX

C#-ADI

Holders with CAMFIX
Exchangeable Shanks
for Boring Bars

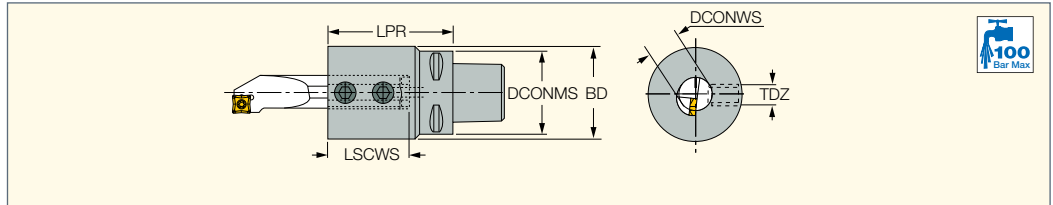

Designation	DCONMS	LPR	LSCWS	DCONWS	BD	TDZ		DCP ⁽¹⁾				
C3 ADI 10	32.00	50.00	20.0	10.00	36.00	M6	0.30	0	SR M6X10 DIN1835B	HW 3.0*		
C3 ADI 12	32.00	50.00	21.5	12.00	36.00	M8	0.30	0	SR M8X10 DIN1835-B	HW 4.0*		
C3 ADI 16	32.00	50.00	29.5	16.00	36.00	M8	0.30	0	SR M8X10 DIN1835-B	HW 4.0*		
C4 ADI 10	40.00	50.00	20.0	10.00	36.00	M6	0.47	1	SR M6X10 DIN1835B	HW 3.0*	COOLING TUBE C4*	WRENCH COOL TUBE C4*
C4 ADI 12	40.00	50.00	24.0	12.00	36.00	M8	0.46	1	SR M8X10 DIN1835-B	HW 4.0*	COOLING TUBE C4*	WRENCH COOL TUBE C4*
C4 ADI 16	40.00	50.00	32.0	16.00	36.00	M8	0.43	1	SR M8X10 DIN1835-B	HW 4.0*	COOLING TUBE C4*	WRENCH COOL TUBE C4*
C4 ADI 20	40.00	60.00	40.0	20.00	36.00	M10	0.47	1	SR M10X12 DIN1835-B	HW 5.0*	COOLING TUBE C4*	WRENCH COOL TUBE C4*
C4 ADI 25	40.00	70.00	45.0	25.00	54.00	M12	0.97	1	SR M12X16 DIN1835-B	HW 6.0*	COOLING TUBE C4*	WRENCH COOL TUBE C4*
C5 ADI 10	50.00	60.00	26.0	10.00	36.00	M6	0.73	1	SR M6X10 DIN1835B	HW 3.0*	COOLING TUBE C5*	WRENCH COOL TUBE C5*
C5 ADI 12	50.00	60.00	26.0	12.00	36.00	M8	0.72	1	SR M8X10 DIN1835-B	HW 4.0*	COOLING TUBE C5*	WRENCH COOL TUBE C5*
C5 ADI 16	50.00	60.00	32.0	16.00	36.00	M8	0.69	1	SR M8X10 DIN1835-B	HW 4.0*	COOLING TUBE C5*	WRENCH COOL TUBE C5*
C5 ADI 20	50.00	60.00	40.0	20.00	36.00	M10	0.69	1	SR M10X12 DIN1835-B	HW 5.0*	COOLING TUBE C5*	WRENCH COOL TUBE C5*
C5 ADI 25	50.00	70.00	50.0	25.00	54.00	M12	1.11	1	SR M12X16 DIN1835-B	HW 6.0*	COOLING TUBE C5*	WRENCH COOL TUBE C5*
C5 ADI 32	50.00	100.00	76.0	32.00	68.00	M12	2.15	1	SR M12X16 DIN1835-B	HW 6.0*	COOLING TUBE C5*	WRENCH COOL TUBE C5*
C6 ADI 12	63.00	65.00	36.0	12.00	36.00	M8	1.07	1	SR M8X10 DIN1835-B	HW 4.0*	COOLING TUBE C6*	WRENCH COOL TUBE C6*
C6 ADI 16	63.00	65.00	36.0	16.00	36.00	M8	1.05	1	SR M8X10 DIN1835-B	HW 4.0*	COOLING TUBE C6*	WRENCH COOL TUBE C6*
C6 ADI 20	63.00	65.00	40.0	20.00	36.00	M10	1.00	1	SR M10X12 DIN1835-B	HW 5.0*	COOLING TUBE C6*	WRENCH COOL TUBE C6*
C6 ADI 25	63.00	76.00	51.0	25.00	54.00	M12	0.80	1	SR M12X16 DIN1835-B	HW 6.0*	COOLING TUBE C6*	WRENCH COOL TUBE C6*
C6 ADI 32	63.00	100.00	76.0	32.00	68.00	M12	2.44	1	SR M12X16 DIN1835-B	HW 6.0*	COOLING TUBE C6*	WRENCH COOL TUBE C6*
C6 ADI 40	63.00	100.00	76.0	40.00	98.00	M12	4.47	1	SR M12X16 DIN1835-B	HW 6.0*	COOLING TUBE C6*	WRENCH COOL TUBE C6*
C6 ADI 50	63.00	115.00	76.0	50.00	98.00	M12	4.80	1	SR M12X16 DIN1835-B	HW 6.0*	COOLING TUBE C6*	WRENCH COOL TUBE C6*
C8 ADI 12	80.00	70.00	36.0	12.00	36.00	M8	2.05	1	SR M8X10 DIN1835-B	HW 4.0*	COOLING TUBE C8*	WRENCH COOL TUBE C8*
C8 ADI 16	80.00	70.00	36.0	16.00	36.00	M8	2.00	1	SR M8X10 DIN1835-B	HW 4.0*	COOLING TUBE C8*	WRENCH COOL TUBE C8*
C8 ADI 20	80.00	70.00	40.0	20.00	36.00	M10	1.98	1	SR M10X12 DIN1835-B	HW 5.0*	COOLING TUBE C8*	WRENCH COOL TUBE C8*
C8 ADI 25	80.00	80.00	51.0	25.00	54.00	M12	2.43	1	SR M12X16 DIN1835-B	HW 6.0*	COOLING TUBE C8*	WRENCH COOL TUBE C8*
C8 ADI 32	80.00	110.00	86.0	32.00	68.00	M12	3.44	1	SR M12X16 DIN1835-B	HW 6.0*	COOLING TUBE C8*	WRENCH COOL TUBE C8*
C8 ADI 40	80.00	115.00	86.0	40.00	98.00	M12	5.81	1	SR M12X16 DIN1835-B	HW 6.0*	COOLING TUBE C8*	WRENCH COOL TUBE C8*
C8 ADI 50	80.00	115.00	86.0	50.00	98.00	M12	5.36	1	SR M12X16 DIN1835-B	HW 6.0*	COOLING TUBE C8*	WRENCH COOL TUBE C8*

• Use the tools with "AD" suffix

• Regular tools should be shortened

⁽¹⁾ 1 - Slot for data chip, 0 - Without slot for data chip

* Optional, to be ordered separately

CAMFIX

C#-ABB

Adapters with CAMFIX
Exchangeable Shanks for Boring
Bars with Reduction Sleeves

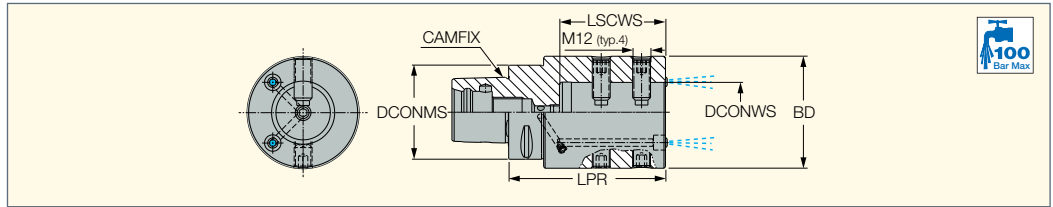

Designation	DCONMS	DCONWS	BD	LPR	LSCWS	DCP ⁽²⁾
C4 ABB 25-60	40.00	25.00	63.00	100.00	60.0	1
C5 ABB-25-60	50.00	25.00	63.00	100.00	60.0	1
C6 ABB-25-60	63.00	25.00	63.00	100.00	60.0	1
C6ABB-25-60C ⁽¹⁾	63.00	25.00	63.00	95.00	60.0	0
C6 ABB-40-70	63.00	40.00	75.00	105.00	71.0	1
C6ABB-40-70C ⁽¹⁾	63.00	40.00	75.00	105.00	71.0	0
C8 ABB 25-60	80.00	25.00	63.00	100.00	60.0	1
C8 ABB 40-72	80.00	40.00	75.00	105.00	71.0	1

• For SC reduction sleeves, see page 840

⁽¹⁾ Different coolant outlet position and number of screws

⁽²⁾ 1 - Slot for data chip, 0 - Without slot for data chip

Spare Parts

Designation								
C4 ABB 25-60	SR M10X12 DIN1835-B ^(a)	SR M10X20 DIN915 ^(b)	SR M10X6DIN913 ^(c)	HW 5.0*	SATZ-M12X1-M6	WRENCH NOZZLE HP M12*	COOLING TUBE C4*	WRENCH COOL TUBE C4*
C5 ABB-25-60	SR M10X12 DIN1835-B ^(a)	SR M10X20 DIN915 ^(b)	SR M10X6DIN913 ^(c)	HW 5.0*	SATZ-M12X1-M6	WRENCH NOZZLE HP M12*	COOLING TUBE C5*	WRENCH COOL TUBE C5*
C6 ABB-25-60	SR M10X12 DIN1835-B ^(a)	SR M10X20 DIN915 ^(b)	SR M10X6DIN913 ^(c)	HW 5.0*	SATZ-M12X1-M6	WRENCH NOZZLE HP M12*	COOLING TUBE C6*	WRENCH COOL TUBE C6*
C6ABB-25-60C	SR M10X12 DIN1835-B	SR M10X20 DIN915*	SR M10X6DIN913	HW 6.0*	SATZ-M12X1-M6	WRENCH NOZZLE HP M12*	COOLING TUBE C6*	WRENCH COOL TUBE C6*
C6 ABB-40-70	SR M12X16 DIN1835-B ^(a)	SR M12X30 DIN915 ^(b)	SR M10X6DIN913 ^(c)	HW 6.0*	SATZ-M12X1-M6	WRENCH NOZZLE HP M12*	COOLING TUBE C6*	WRENCH COOL TUBE C6*
C6ABB-40-70C	SR M12X16 DIN1835-B	SR M12X30 DIN915*	SR M10X6DIN913	HW 6.0*	SATZ-M12X1-M6	WRENCH NOZZLE HP M12*	COOLING TUBE C6*	WRENCH COOL TUBE C6*
C8 ABB 25-60	SR M10X12 DIN1835-B ^(a)	SR M10X20 DIN915 ^(b)	SR M10X6DIN913 ^(c)	HW 5.0*	SATZ-M12X1-M6	WRENCH NOZZLE HP M12*	COOLING TUBE C8*	WRENCH COOL TUBE C8*
C8 ABB 40-72	SR M12X16 DIN1835-B ^(a)	SR M12X30 DIN915 ^(b)	SR M10X6DIN913 ^(c)	HW 6.0*	SATZ-M12X1-M6	WRENCH NOZZLE HP M12*	COOLING TUBE C8*	WRENCH COOL TUBE C8*

* Optional, to be ordered separately

^(a) Used on A-type sleeves

^(b) Used on B-type sleeves

^(c) Rear stopper screw

WHISPERLINE

C#-AV-JHP

CAMFIX Holders for
Anti-Vibration Tools

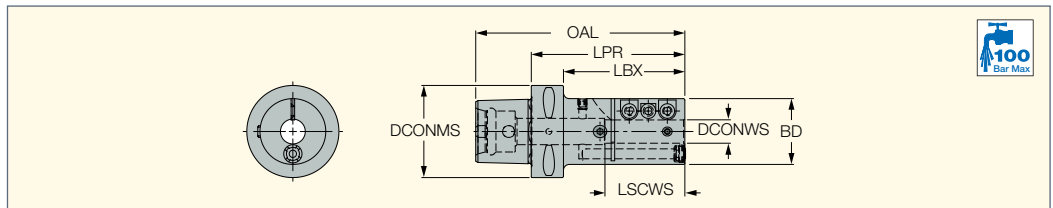

Designation	DCONMS	DCONWS	OAL	BD	LPR	LSCWS	LBX	
C6 AV-D16-JHP	63.00	16.00	143.00	45.00	105.00	55.00	83.00	1.57
C6 AV-D20-JHP	63.00	20.00	143.00	55.00	105.00	80.00	83.00	2.00
C6 AV-D25-JHP	63.00	25.00	143.00	55.00	105.00	80.00	83.00	1.89
C6 AV-D32-JHP	63.00	32.00	143.00	65.00	105.00	85.00	66.60	2.23
C6 AV-D40-JHP	63.00	40.00	143.00	75.00	105.00	85.00	64.00	2.49

CAMFIX

C#-ASHR/L-HPMC
 Holders with CAMFIX
 Exchangeable Shanks for
 External Square Shank Tools with
 High-Pressure Multi-Connection

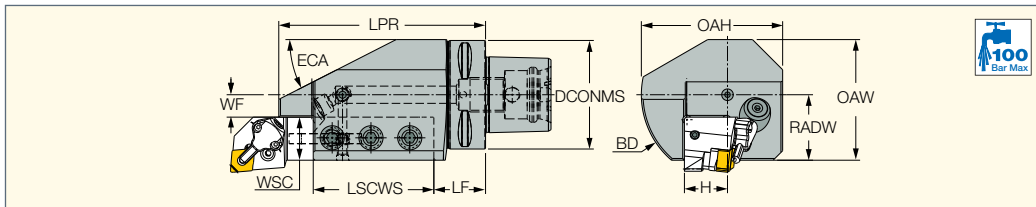

Designation	DCONMS	LPR	LSCWS	LF	WF	H	WSC	OAH	RADW	OAW	BD	ECA	DCP ⁽²⁾
C6 ASHR/L 25-1 HPMC	63.00	120.00	70.00	30.00	13.00	25.0	25.0	82.00	38.00	70.00	100.00	27.0	1
C6 ASHR 25-1-J HPMC ⁽¹⁾	63.00	120.00	82.00	38.00	4.50	25.0	25.0	76.00	29.50	61.00	90.00	4.1	1

⁽¹⁾ Recommended for Mazak INTEGREX! No interference problem on machine magazine

⁽²⁾ 1 - Slot for data chip, 0 - Without slot for data chip

Spare Parts

Designation									
C6 ASHR/L 25-1 HPMC	SATZ-M12X1-M6	SR M12X30 DIN915	SR M8X6 DIN913	SR M6X6 DIN913	HW 6.0°	COOLING TUBE C6*	WRENCH COOL TUBE C6*	WRENCH NOZZLE HP M12*	

* Optional, to be ordered separately

CAMFIX

C#-ASHR/L-45-HPMC
 Holders with CAMFIX
 Exchangeable Shanks Carrying
 Square Shank Tools for 45°
 Mounting on Turn-Mill
 Machines with HPMC

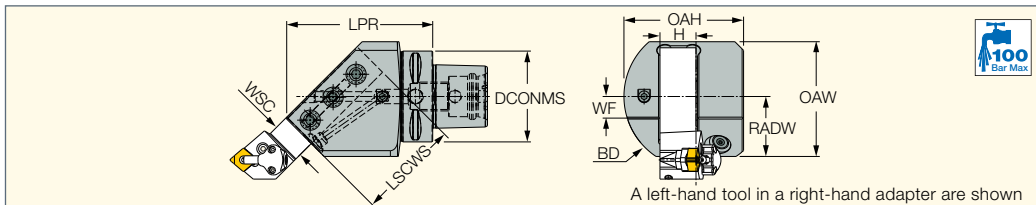

Designation	DCONMS	H	WSC	LSCWS	LPR	OAH	RADW	OAW	WF	BD	DCP ⁽¹⁾
C6 ASHR/L 25-45 HPMC	63.00	25.0	25.0	70.00	101.30	83.00	38.00	79.60	15.00	100.00	1

⁽¹⁾ 1 - Slot for data chip, 0 - Without slot for data chip

Spare Parts

Designation									
C6 ASHR/L 25-45 HPMC	SATZ-M10X1-M5	SR M12X30 DIN915	SR M8X6 DIN913	SR M6X6 DIN913	HW 6.0°	COOLING TUBE C6*	WRENCH COOL TUBE C6*	WRENCH NOZZLE HP M10*	

* Optional, to be ordered separately

CAMFIX

C#-ASHA-HPMC
 Perpendicular Holders with
 CAMFIX Shanks for External
 Square Shank Tools with High-
 Pressure Multi-Connection

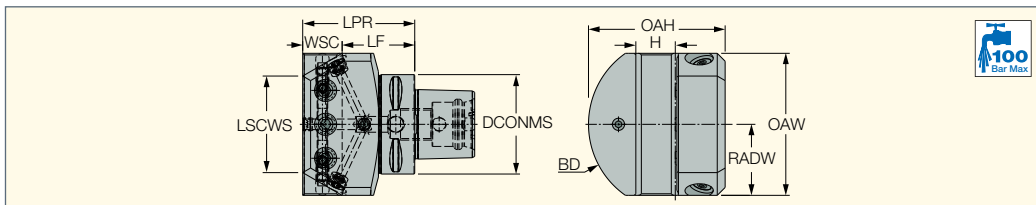

Designation	DCONMS	H	WSC	LPR	LSCWS	LF	RADW	OAW	OAH	BD	DCP ⁽¹⁾
C6 ASHA 25 HPMC	63.00	25.0	25.0	71.00	61.20	46.00	45.00	90.00	86.50	110.00	1

⁽¹⁾ 1 - Slot for data chip, 0 - Without slot for data chip

Spare Parts

Designation									
C6 ASHA 25 HPMC	SATZ-M12X1-M6	SR M12X30 DIN915	SR M8X6 DIN913	SR M6X6 DIN913	HW 6.0°	COOLING TUBE C6*	WRENCH COOL TUBE C6*	WRENCH NOZZLE HP M12*	

* Optional, to be ordered separately

HSK A WH Complies with ICTM Standards (ISO 12164-3)

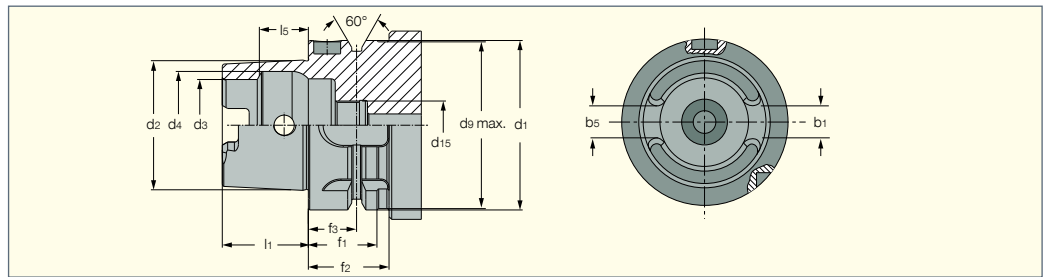

HSK-A WH	d1 h10	d2	d3 H10	d4 H11	d9 max	d15	l1-0.2	l5 JS10	b1±0.04	b5±0.035	f1 -0.1	f2 min	f3 ±0.1
63	63	48	34	40	62	M18X1	32	18.13	12.54	12.425	26	30	18
100	100	75	53	63	99	M24X1.5	50	28.56	20.02	19.91	29	34	20

HSK A TM Suitable for all Multi-Tasking Machines Models

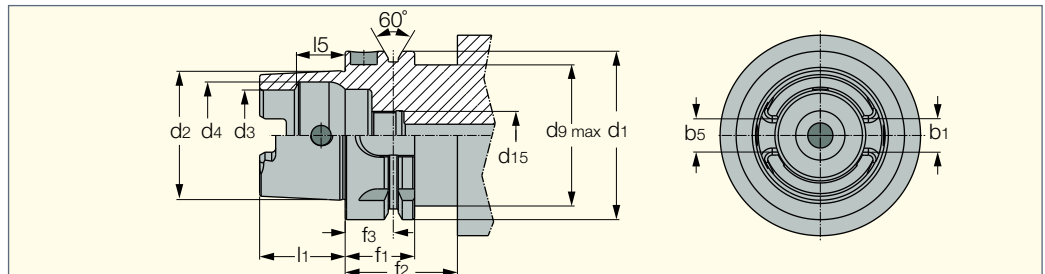

HSK A-TM	d1 h10	d2	d3 H10	d4 H11	d9 max	d15	l1-0.2	l5 JS10	b1±0.04	b5±0.035	f1-0.1	f2 min	f3±0.1
63	63	48	34	40	52.8	M18x1	32	18.13	12.54	12.425	26	42	18

HSK A vs. HSK A...WH Tolerance

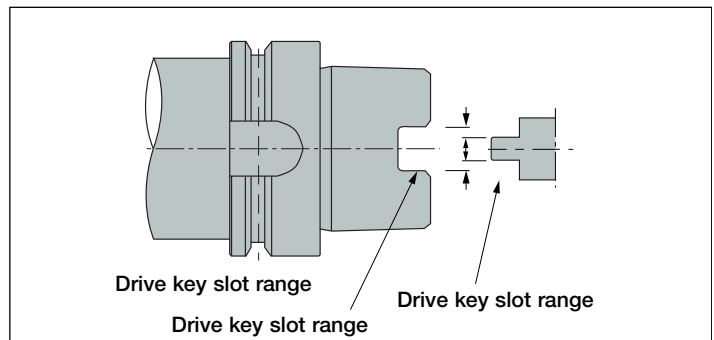
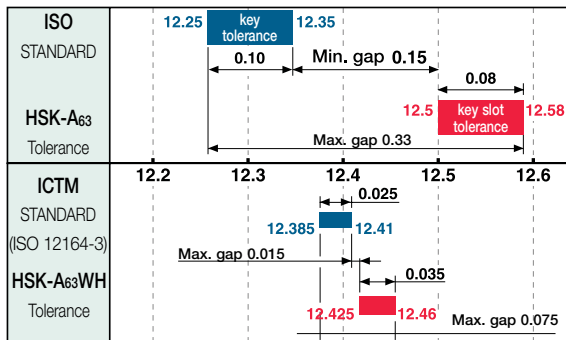

HSK

HSK-C#
CAMFIX (ISO 26623-1) Holders with HSK ISO 12164-3 Form A Tapered Shanks

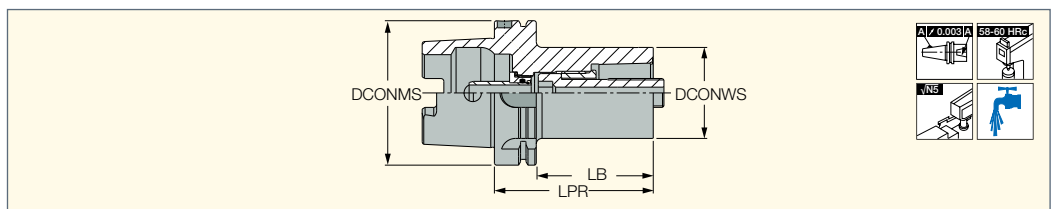

Designation	DCONMS	DCONWS	LPR	LB	DCP ⁽¹⁾	kg
C4 AD HSK A63WHX080	63.00	40.00	80.00	54.00	1	1.10
C5 AD HSK A63WHX90	63.00	50.00	90.00	64.00	1	1.44
C5 AD HSK A100WHX100	100.00	50.00	100.00	71.00	1	2.90
C6 AD HSK A100WHX110	100.00	63.00	110.00	81.00	1	3.61
C8 AD HSK A100WHX120	100.00	80.00	120.00	91.00	1	4.79

• Note: To enable clamping the part to be attached, first remove the cooling tube
(1) 1 - Slot for data chip, 0 - Without slot for data chip

Spare Parts

Designation						
C4 AD HSK A63WHX080	SR M14x58 C4	HW 8.0*	MT RING M22X17XC4	COOLING TUBE HSK A63	WRENCH COOL TUBE HSK63*	WRENCH C4 DRW NUT*
C5 AD HSK A63WHX90	SR M16x70 C5	HW 10.0*	MT RING M25X20XC5	COOLING TUBE HSK A63	WRENCH COOL TUBE HSK63*	WRENCH C5 DRW NUT*
C5 AD HSK A100WHX100	SR M16x70 C5	HW 10.0*	MT RING M25X20XC5	COOLING TUBE HSK A100	WRENCH COOL TUBE HSK100*	WRENCH C5 DRW NUT*
C6 AD HSK A100WHX110	SR M20x87 C6/8	HW 14.0*	MT RING M30X24XC6/8	COOLING TUBE HSK A100C6/8	WRENCH COOL TUBE HSK100*	WRENCH C6-8 DRW NUT*
C8 AD HSK A100WHX120	SR M20x87 C6/8	HW 14.0*	MT RING M30X24XC6/8	COOLING TUBE HSK A100C6/8	WRENCH COOL TUBE HSK100*	WRENCH C6-8 DRW NUT*



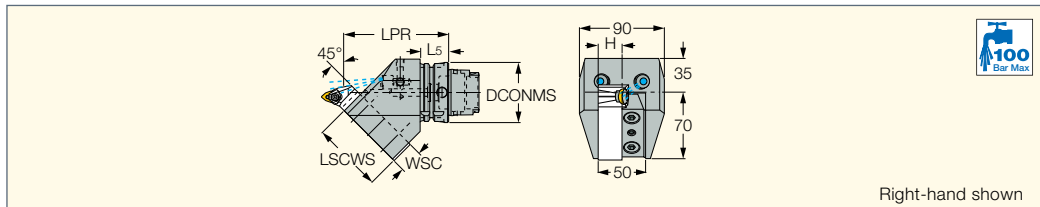

* Optional, to be ordered separately

HSK

HSK A-WH-ASHN-45
Square Shank Tool Adapters
with HSK Exchangeable
Shanks for 45° Mounting
on Turn-Mill Machines



Right-hand shown

Designation	DCONMS	H	WSC	LPR	LSCWS	L5	DCP ⁽²⁾				
HSK A63WH ASHN 25 45 ⁽¹⁾	63.00	25.0	25.0	110.00	72.00	30.00	1	SR M10X25 DIN912	SR M8X20 DIN916	SATZ-M12X1-M6	WRENCH NOZZLE HP M12*
HSK A100WH ASHN 32 45*	100.00	32.0	32.0	145.00	100.00	35.00	1	SR M10X35 DIN912		SATZ-M12X1-M6	



- A cooling tube must be used with all coolant through HSK spindles (should be ordered separately)
 - For using left-hand toolholder, the position of the clamping spacer must be changed
 - Complies with ICTM standard (ISO 12164-3)
- ⁽¹⁾ Not suitable for ATC (automatic tool changer) on some multi-tasking machine models, please consult your MTB
⁽²⁾ 1 - Slot for data chip, 0 - Without slot for data chip
 * Optional, to be ordered separately

HSK

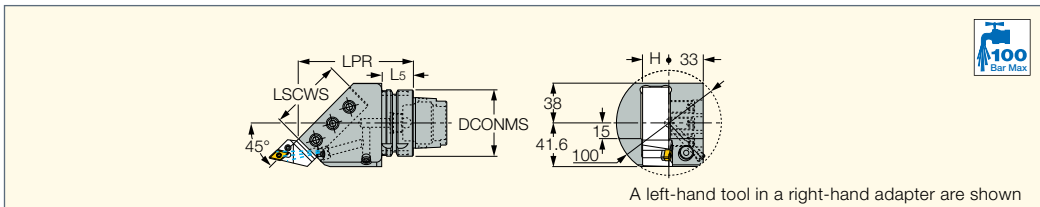
HSK A63WH-ASHR/L-45
Square Shank Tool Adapters
with HSK-T Exchangeable
Shanks for 45° Mounting
on Turn-Mill Machines



A left-hand tool in a right-hand adapter are shown

Designation	DCONMS	H	LPR	LSCWS	L5	DCP ⁽²⁾			
HSK A63WH ASHR/L 25 45 ⁽¹⁾	63.00	25.0	110.00	70.00	30.00	1	SR M12X30 DIN915	SATZ-M10X1-M5	WRENCH NOZZLE HP M10*

- A cooling tube must be used with all coolant through HSK spindles (should be ordered separately)
 - Complies with ICTM standard (ISO 12164-3)
- ⁽¹⁾ Not suitable for ATC (automatic tool changer) on some multi-tasking machine models, please consult your MTB
⁽²⁾ 1 - Slot for data chip, 0 - Without slot for data chip
 * Optional, to be ordered separately

HSK

HSK A-WH-ASHR/L-1
Square Shank Tool Adapters
with HSK Exchangeable
Shanks for Turn-Mill Machines

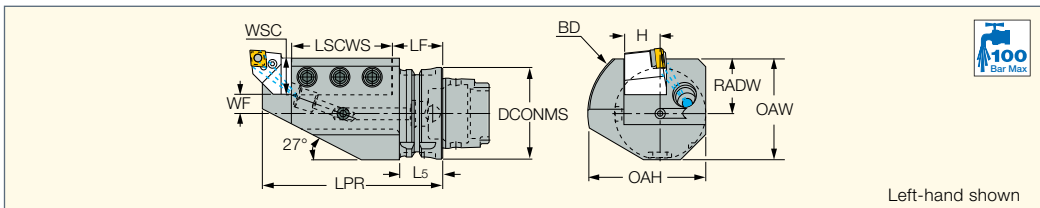

Left-hand shown

Designation	DCONMS	H	WSC	WF	LPR	LSCWS	LF	L5	OAH	RADW	OAW	BD	DCP ⁽¹⁾
HSK A63WH ASHR/L 25 1	63.00	25.0	25.0	13.00	125.00	70.00	35.00	30.00	82.00	38.0	70.00	100.00	1
HSK A100WH ASHR/L 32 1	100.00	32.0	32.0	8.00	145.00	90.00	45.00	38.00	85.00	40.0	84.00	100.00	1

- Complies with ICTM standard (ISO 12164-3)
- Not suitable for ATC (automatic tool changer) on some multi-tasking machine models, please consult your MTB
 • A cooling tube must be used with all coolant through HSK spindles (should be ordered separately)
⁽¹⁾ 1 - Slot for data chip, 0 - Without slot for data chip

Spare Parts

Designation				
HSK A-WH-ASHR/L-1	SR M12X30 DIN915	HW 6.0*	SATZ-M12X1-M6	WRENCH NOZZLE HP M12*

- * Optional, to be ordered separately

HSK

HSK A63WH-ASHR/L-2
Twin Square Shank Tool
Adapters with HSK Exchangeable
Shanks for Turn-Mill Machines

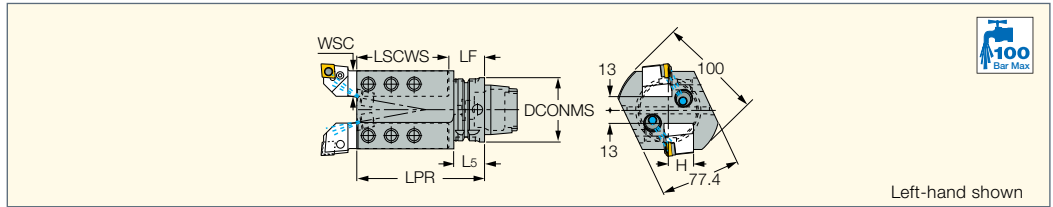

Left-hand shown

Designation	DCONMS	H	LF	WSC	LPR	LSCWS	L5	DCP ⁽²⁾			
HSK A63WH ASHR/L 25 2 ⁽¹⁾	63.00	25.0	35.00	25.0	125.00	95.00	30.00	1	SR M12X30 DIN915	SATZ-M12X1-M6	WRENCH NOZZLE HP M12*

- Complies with ICTM standard (ISO 12164-3)
- A cooling tube must be used with all coolant through HSK spindles (should be ordered separately)
- ⁽¹⁾ Not suitable for ATC (automatic tool changer) on some multi-tasking machine models, please consult your MTB
- ⁽²⁾ 1 - Slot for data chip, 0 - Without slot for data chip
- * Optional, to be ordered separately

HSK

HSK A63WH-ASHR/L-3
Triple Square Shank
Tool Adapters with HSK
Exchangeable Shanks for
Mounting on Turn-Mill Machines

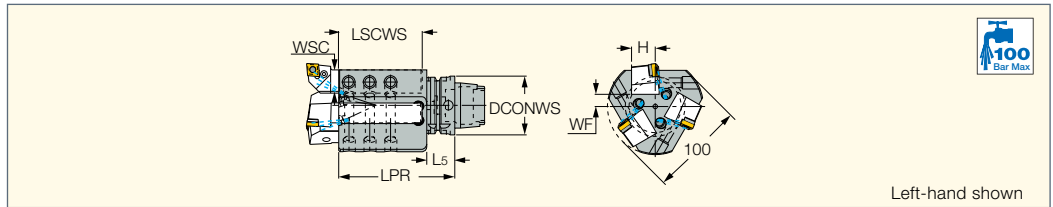

Left-hand shown

Designation	DCONMS	H	WSC	WF	LPR	LSCWS	L5	DCP ⁽²⁾		
HSK A63WH ASHR/L 25 3 ⁽¹⁾	63.00	25.0	25.0	13.00	125.00	90.00	30.00	1	SR M12X30 DIN915	SATZ-M8X1-M3

- Complies with ICTM standard (ISO 12164-3)
- A cooling tube must be used with all coolant through HSK spindles (should be ordered separately)
- ⁽¹⁾ Not suitable for ATC (automatic tool changer) on some multi-tasking machine models, please consult your MTB
- ⁽²⁾ 1 - Slot for data chip, 0 - Without slot for data chip

HSK

HSK A-WH ABB
Adapters with HSK
Exchangeable Shanks for Boring
Bars with Reduction Sleeves

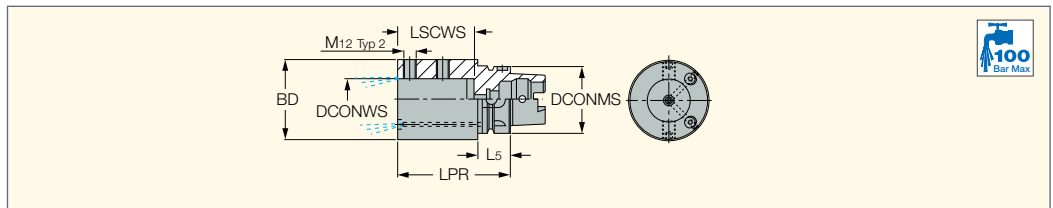

Designation	DCONMS	BD	DCONWS	LPR	LSCWS	L5	DCP ⁽¹⁾
HSK A63WH ABB 40	63.00	75.00	40.00	105.00	71.0	30.00	1
HSK A100WH ABB 40	100.00	82.00	40.00	115.00	71.0	29.00	1
HSK A100WH ABB 50	100.00	92.00	50.00	125.00	83.0	29.00	1

- Complies with ICTM standard (ISO 12164-3)
- Not suitable for ATC (automatic tool changer) on some multi-tasking machine models, please consult your MTB
- A cooling tube must be used with all coolant through HSK spindles (should be ordered separately)
- ⁽¹⁾ 1 - Slot for data chip, 0 - Without slot for data chip

Spare Parts

Designation						
HSK A-WH ABB	SR M12X16 DIN1835-B ^(a)	SR M12X30 DIN915 ^(b)	SR M10X6DIN913 ^(c)	HW 6.0*	SATZ-M12X1-M6	WRENCH NOZZLE HP M12*

- * Optional, to be ordered separately
- ^(a) Used on A-type sleeves
- ^(b) Used on B type sleeves
- ^(c) Rear stopper screw

HSK

HSK A63WH-ASHR/L-HPMC
 Holders with HSK Exchangeable Shanks for External Square Shank Tools with High-Pressure Multi-Connection

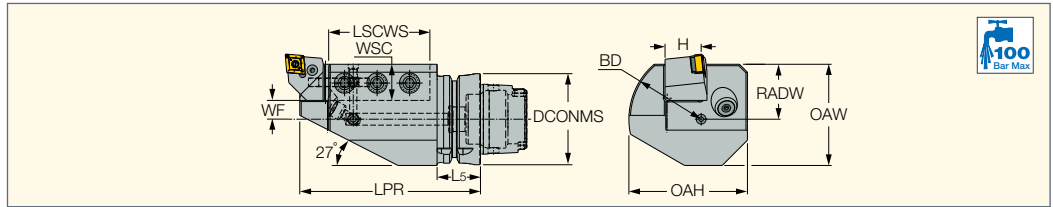

Designation	DCONMS	LPR	LSCWS	L5	WF	H	WSC	OAH	RADW	OAW	BD	DCP ⁽¹⁾
HSK A63WH ASHR/L25-1 HPMC	63.00	125.00	70.00	30.00	13.00	25.0	25.0	82.00	38.00	70.00	100.00	1

⁽¹⁾ 1 - Slot for data chip, 0 - Without slot for data chip

HSK

HSK A63WH-ASHR/L-45-HPMC
 Holders with HSK Exchangeable Shanks Carrying Square Shank Tools for 45° Mounting on Turn-Mill Machines with HPMC

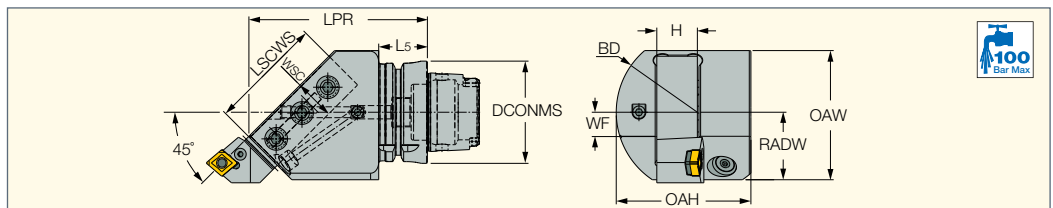

Designation	DCONMS	H	WSC	LSCWS	LPR	L5	OAH	RADW	OAW	WF	BD	DCP ⁽¹⁾
HSK A63WH ASHR/L25-45 HPMC	63.00	25.0	25.0	70.00	110.00	30.00	83.00	41.60	79.60	15.00	100.00	1

⁽¹⁾ 1 - Slot for data chip, 0 - Without slot for data chip

Spare Parts

Designation		
HSK A63WH ASHL25-45 HPMC	SR M6X6 DIN913	SR M12X30 DIN915
HSK A63WH ASHR25-45 HPMC	SR M6X6 DIN913	SR M8X6 DIN913

HSK

HSK A-TM-ASHR/L-1-HPMC
 Square Shank Tool Adapters with HSK Exchangeable Shanks for Multi-Tasking Machines with High-Pressure Coolant Channels

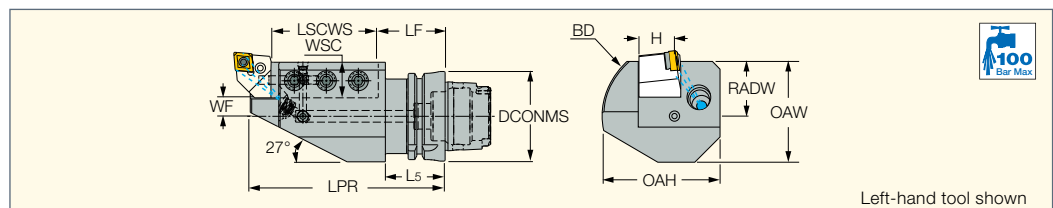

Designation	DCONMS	H	WSC	WF	LPR	LSCWS	LF	L5	OAH	RADW	OAW	BD	DCP ⁽¹⁾
HSK A63TM ASHR/L 25 1 HPMC	63.00	25.0	25.0	13.00	137.00	70.00	47.00	42.00	82.00	38.0	70.00	100.00	1

• A cooling tube must be used with all coolant through HSK spindles (should be ordered separately)

⁽¹⁾ 1 - Slot for data chip, 0 - Without slot for data chip

Spare Parts

Designation					
HSK A63TM ASHR/L 25 1 HPMC	SR M12X30 DIN915	SR M8X6 DIN913	SATZ-M12X1-M6	WRENCH NOZZLE HP M12*	SR M6X6 DIN913

* Optional, to be ordered separately

HSK

HSK A63TM-ASHR/L-45-HPMC

Square Shank Tool Adapters with HSK-T Exchangeable Shanks for 45° Mounting on Multi-Tasking Machines

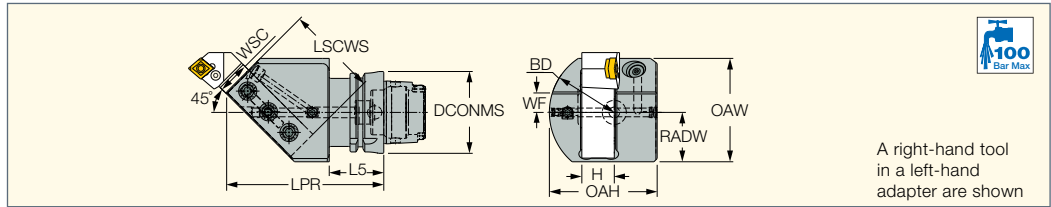

A right-hand tool in a left-hand adapter are shown

Designation	DCONMS	H	WSC	WF	LPR	LSCWS	L5	OAH	RADW	OAW	BD	DCP ⁽¹⁾
HSK A63TM ASHR/L 25 45 HPMC	63.00	25.0	25.0	15.00	121.00	70.00	42.00	58.00	38.00	79.60	100.00	1

- A cooling tube must be used with all coolant through HSK spindles (should be ordered separately)
- (1) 1 - Slot for data chip, 0 - Without slot for data chip

Spare Parts

Designation					
HSK A63TM ASHR/L 25 45 HPMC	SR M12X30 DIN915	SR M8X6 DIN913	SATZ-M12X1-M6	WRENCH NOZZLE HP M12*	SR M6X6 DIN913

* Optional, to be ordered separately

HSK

HSK A63TM-ASHN-45-HPMC

Square Shank Tool Adapters with HSK Exchangeable Shanks for 45° Mounting on Multi-Tasking Machines

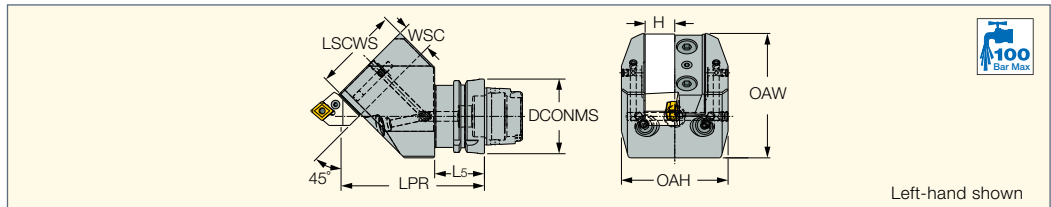

Left-hand shown

Designation	DCONMS	H	WSC	LPR	LSCWS	L5	OAH	OAW	DCP ⁽¹⁾
HSK A63TM ASHN 25 45 HPMC	63.00	25.0	25.0	121.00	72.00	42.00	90.00	105.00	1

- A cooling tube must be used with all coolant through HSK spindles (should be ordered separately)
- For using left-hand toolholder, the position of the clamping spacer must be changed
- (1) 1 - Slot for data chip, 0 - Without slot for data chip

Spare Parts

Designation							
HSK A63TM ASHN 25 45 HPMC	SR M10X25 DIN912	SR M8X20 DIN916	SATZ-M12X1-M6	WRENCH NOZZLE HP M12*	SPRING PIN DIN 1481 3X5	SR M8X6 DIN913	SR M6X6 DIN913

* Optional, to be ordered separately

HSK

HSK A63TM ABB

Adapters with HSK Exchangeable Shanks for Boring Bars with Reduction Sleeves

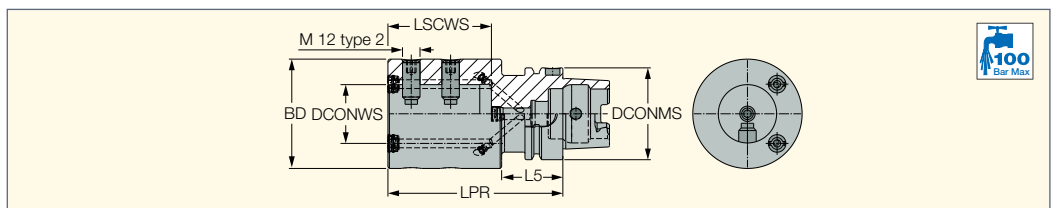

Designation	DCONMS	DCONWS	BD	LPR	LSCWS	L5	DCP ⁽¹⁾
HSK A63TM ABB 40	63.00	40.00	75.00	120.00	71.0	42.00	1

- A cooling tube must be used with all coolant through HSK spindles (should be ordered separately)
- For SC reduction sleeves, see page 840
- (1) 1 - Slot for data chip, 0 - Without slot for data chip

Spare Parts

Designation							
HSK A63TM ABB 40	SR M12X30 DIN915	SR M12X16 DIN1835-B	SATZ-M12X1-M6	WRENCH NOZZLE HP M12*	SR M10X6DIN913	SR M5X4 DIN913	COOLING TUBE HSK A63*

* Optional, to be ordered separately

Accessories

SC-T (sleeves)

Reduction Sleeves for Holders with Exchangeable Adaptation

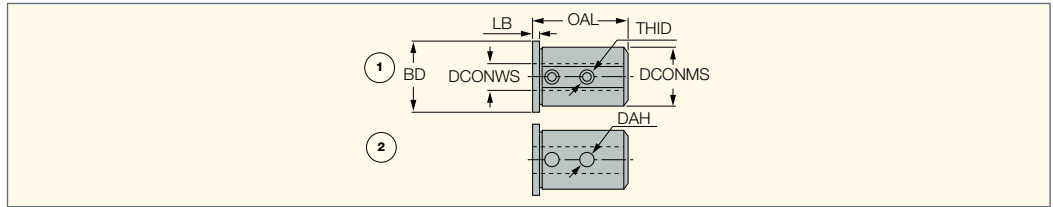

Designation	DCONMS	DCONWS	BD	OAL	LB	THID	DAH	Fig.		
SC 32T10A	32.00	10.00	39.00	70.00	8.00	M6	-	1		
SC 32T12A	32.00	12.00	39.00	70.00	8.00	M6	-	1		
SC 32T16A	32.00	16.00	39.00	70.00	8.00	M6	-	1		
SC 32T20A	32.00	20.00	39.00	70.00	8.00	M6	-	1		
SC 32T25B	32.00	25.00	39.00	80.00	15.00	-	-	2		
SC 25T10A	25.00	10.00	31.00	62.00	6.00	M8	-	1	SR M8X6 DIN916	HW 4.0*
SC 25T12A	25.00	12.00	31.00	62.00	6.00	M8	-	1	SR M8X6 DIN916	HW 4.0*
SC 25T16B	25.00	16.00	31.00	62.00	6.00	-	12.00	2		
SC 25T20B	25.00	20.00	31.00	62.00	6.00	-	12.00	2		
SC 25T6A	25.00	6.00	31.00	62.00	6.00	M6	-	1	SR M6X6 DIN916	HW 3.0*
SC 25T8A	25.00	8.00	31.00	62.00	6.00	M8	-	1	SR M8X6 DIN916	HW 4.0*
SC 40T10A	40.00	10.00	46.00	66.00	6.00	M8	-	1	SR M8X10 DIN1835-B	HW 4.0*
SC 40T12A	40.00	12.00	46.00	66.00	6.00	M8	-	1	SR M8X10 DIN1835-B	HW 4.0*
SC 40T16B	40.00	16.00	46.00	66.00	6.00	-	15.00	2		
SC 40T20B	40.00	20.00	46.00	66.00	6.00	-	15.00	2		
SC 40T25B	40.00	25.00	46.00	66.00	6.00	-	15.00	2		
SC 40T32B	40.00	32.00	46.00	66.00	6.00	-	15.00	2		
SC 40T6A	40.00	6.00	46.00	66.00	6.00	M6	-	1	SR M6X10 DIN1835B	HW 3.0*
SC 40T8A	40.00	8.00	46.00	66.00	6.00	M6	-	1	SR M8X10 DIN1835-B	HW 4.0*
SC 50 T40B	50.00	40.00	56.00	86.00	6.00	-	15.00	2		
SC 50T10A	50.00	10.00	56.00	76.00	6.00	M8	-	1	SR M8X6 DIN916	HW 4.0*
SC 50T12A	50.00	12.00	56.00	76.00	6.00	M8	-	1	SR M8X6 DIN916	HW 4.0*
SC 50T16B	50.00	16.00	56.00	86.00	6.00	-	15.00	2		
SC 50T20B	50.00	20.00	56.00	86.00	6.00	-	15.00	2		
SC 50T25B	50.00	25.00	56.00	86.00	6.00	-	15.00	2		
SC 50T32B	50.00	32.00	56.00	86.00	6.00	-	15.00	2		
SC 50T6A	50.00	6.00	56.00	76.00	6.00	M6	-	1	SR M6X6 DIN916	HW 3.0*
SC 50T8A	50.00	8.00	56.00	76.00	6.00	M8	-	1	SR M8X6 DIN916	HW 4.0*

* Optional, to be ordered separately

TOOL BLOCKS

VDI-B1/B4A-JHPMC

Radially Oriented, Short, Right-Hand Holders with VDI DIN69880 Shanks for Square Shank Tools

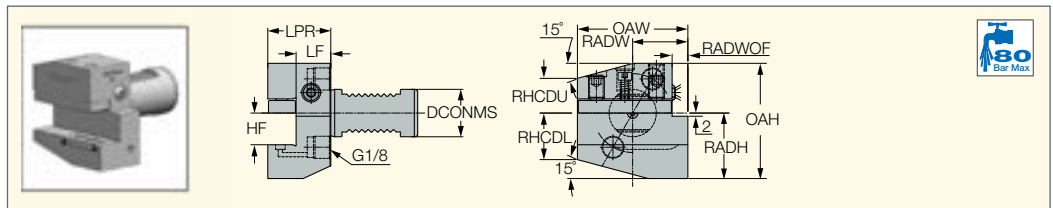

Designation	DCONMS	HF	LPR	OAW	RADW	RADWOF	RHCDL	RHCDU	RADH	OAH	DCP ⁽¹⁾
VDI16 B1A-161234-JHPMC	16.00	12.0	34.00	42.00	23.00	5.00	16.00	15.00	22.00	42.00	0
VDI16 B4A-161234-JHPMC	16.00	12.0	34.00	42.00	23.00	5.00	16.00	15.00	22.00	42.00	0
VDI20 B1A-201640-JHPMC	20.00	16.0	40.00	55.00	30.00	7.00	19.00	19.00	30.00	55.00	0
VDI20 B4A-201640-JHPMC	20.00	16.0	40.00	55.00	30.00	7.00	19.00	19.00	30.00	55.00	0
VDI25 B1A-252040-JHPMC	25.00	20.0	40.00	70.00	35.00	10.00	29.50	22.00	38.50	70.00	0
VDI30 B1B4A-302040-JHPMC	30.00	20.0	40.00	70.00	35.00	10.00	29.50	22.00	41.50	73.00	0
VDI40 B1B4A-402544-JHPMC	40.00	25.0	44.00	85.00	42.50	12.50	35.00	30.00	48.00	86.00	0
VDI50 B1B4A-502544-JHPMC	50.00	25.0	44.00	85.00	42.50	12.50	43.00	30.00	48.00	91.00	0

• Form B1 radial R.H. short, form B4 radial overhead L.H. short.

(1) 1 - Slot for data chip, 0 - Without slot for data chip

TOOL BLOCKS

VDI-B1/B4AK-JHPMC
 Radially Oriented, Short, Right-Hand, Wedge Clamping Holders with VDI DIN69880 Shanks for Square Shank Tools

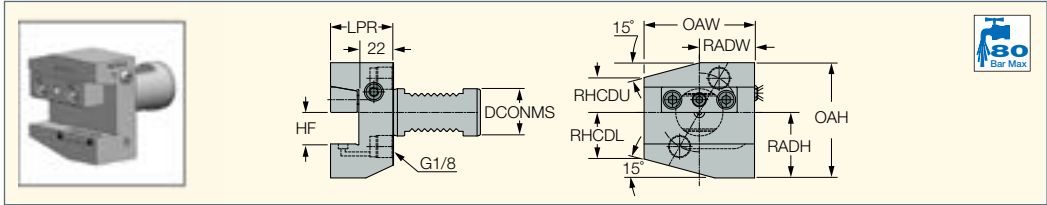

Designation	DCONMS	HF	LPR	OAW	RADW	RHCDL	RHCDU	RADH	OAH	DCP ⁽¹⁾
VDI30 B1B4AK-302040-JHPMC	30.00	20.0	40.00	70.00	35.00	29.50	22.00	41.50	73.00	0
VDI40 B1B4AK-402544-JHPMC	40.00	25.0	44.00	85.00	42.50	35.00	30.00	48.00	86.00	0
VDI50 B1B4AK-502544-JHPMC	50.00	25.0	44.00	85.00	42.50	43.00	30.00	48.00	91.00	0

• Form B1 radial R.H. short, form B4 radial overhead L.H. short.
 (1) 1 - Slot for data chip, 0 - Without slot for data chip

TOOL BLOCKS

VDI-B2/B3A-JHPMC
 Radially Oriented, Short, Left-Hand Holders with VDI DIN69880 Shanks for Square Shank Tools

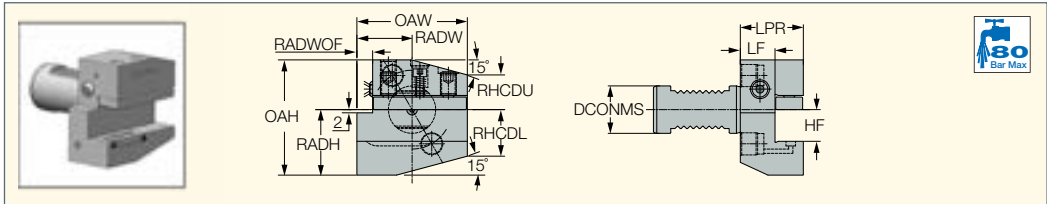

Designation	DCONMS	HF	LPR	OAW	RADW	RADWOF	RHCDL	RHCDU	RADH	OAH	DCP ⁽¹⁾
VDI16 B2A-161234-JHPMC	16.00	12.0	34.00	42.00	23.00	5.00	16.00	15.00	22.00	42.00	0
VDI16 B3A-161234-JHPMC	16.00	12.0	34.00	42.00	23.00	5.00	16.00	15.00	22.00	42.00	0
VDI20 B2A-201640-JHPMC	20.00	16.0	40.00	55.00	30.00	7.00	19.00	19.00	30.00	55.00	0
VDI20 B3A-201640-JHPMC	20.00	16.0	40.00	55.00	30.00	7.00	19.00	19.00	30.00	55.00	0
VDI25 B2A-252040-JHPMC	25.00	20.0	40.00	70.00	35.00	10.00	29.50	22.00	38.50	70.00	0
VDI30 B2B3A-302040-JHPMC	30.00	20.0	40.00	70.00	35.00	10.00	29.50	27.00	41.50	73.00	0
VDI40 B2B3A-402544-JHPMC	40.00	25.0	44.00	85.00	42.50	12.50	35.00	30.00	48.00	86.00	0
VDI50 B2B3A-502544-JHPMC	50.00	25.0	44.00	85.00	42.50	12.50	43.00	38.00	48.00	91.00	0

• Form B2 radial L.H. short, form B3 radial overhead R.H. short.
 (1) 1 - Slot for data chip, 0 - Without slot for data chip

TOOL BLOCKS

VDI-B2/B3AK-JHPMC
 Radially Oriented, Short, Left-Hand, Wedge Clamping Holders with VDI DIN69880 Shanks for Square Shank Tools

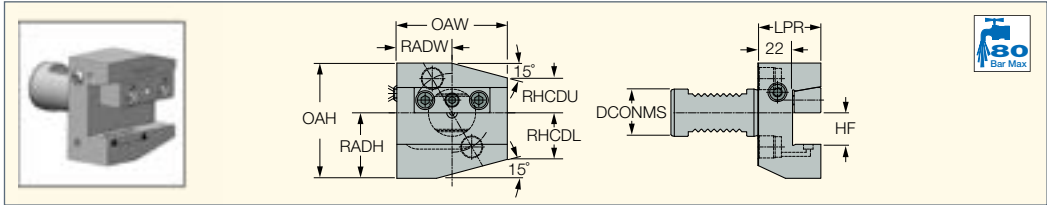

Designation	DCONMS	HF	LPR	OAW	RADW	RHCDL	RHCDU	RADH	OAH	DCP ⁽¹⁾
VDI30 B2B3AK-302040-JHPMC	30.00	20.0	40.00	70.00	35.00	29.50	27.00	41.50	73.00	0
VDI40 B2B3AK-402544-JHPMC	40.00	25.0	44.00	85.00	42.50	35.00	30.00	48.00	86.00	0
VDI50 B2B3AK-502544-JHPMC	50.00	25.0	44.00	85.00	42.50	35.00	38.00	48.00	91.00	0

• Form B2 radial L.H. short, form B3 radial overhead R.H. short.
 (1) 1 - Slot for data chip, 0 - Without slot for data chip

TOOL BLOCKS

VDI-C1/C4A-JHPMC
 Axially Oriented, Short, Right-Hand Holders with VDI DIN69880 Shanks for Square Shank Tools

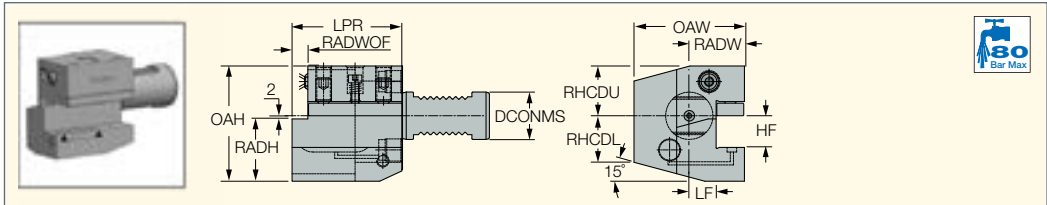

Designation	DCONMS	HF	LPR	OAW	RADW	LF	RADWOF	RHCDL	RHCDU	RADH	OAH	DCP ⁽¹⁾
VDI16 C1C4A-161244-JHPMC	16.00	12.0	44.00	43.00	5.00	13.00	5.00	15.00	15.00	23.00	45.00	0
VDI20 C1C4A-201655-JHPMC	20.00	16.0	55.00	52.00	7.00	13.00	7.00	19.00	19.00	23.00	55.00	0
VDI25 C1C4A-252055-JHPMC	25.00	20.0	55.00	58.00	33.00	13.00	7.00	26.00	28.00	36.00	66.00	0
VDI30 C1C4A-302070-JHPMC	30.00	20.0	70.00	70.00	35.00	17.00	10.00	26.00	22.00	38.00	70.00	0
VDI40 C1C4A-402585-JHPMC	40.00	25.0	85.00	85.00	42.50	21.00	12.50	35.00	30.00	48.00	86.00	0
VDI50 C1C4A-502585-JHPMC	50.00	25.0	85.00	90.50	48.00	26.00	12.50	42.00	35.00	48.00	92.00	0

• Form C1 axial R.H., form C4 axial overhead L.H. short.
 (1) 1 - Slot for data chip, 0 - Without slot for data chip

TOOL BLOCKS

VDI-C1/C4AK-JHPMC
Axially Oriented, Short, Right-Hand, Wedge Clamping Holders with VDI DIN69880 Shanks for Square Shank Tools

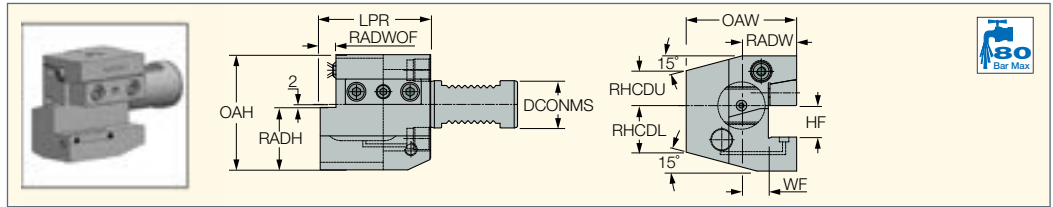

Designation	DCONMS	HF	LPR	OAW	RADW	WF	RADWOF	RHCDL	RHCDU	RADH	OAH	DCP ⁽¹⁾
VDI30 C1C4AK-302070-JHPMC	30.00	20.0	70.00	70.00	35.00	17.00	10.00	26.00	22.00	38.00	70.00	0
VDI40 C1C4AK-402585-JHPMC	40.00	25.0	85.00	85.00	42.50	21.00	12.50	35.00	30.00	48.00	86.00	0
VDI50 C1C4AK-502585-JHPMC	50.00	25.0	85.00	90.50	48.00	26.00	12.50	42.00	35.00	48.00	92.00	0

- Form C1 axial R.H., form C4 axial overhead L.H. short.
- (1) 1 - Slot for data chip, 0 - Without slot for data chip

TOOL BLOCKS

VDI-C2/C3A-JHPMC
Axially Oriented, Short, Left-Hand Holders with VDI DIN69880 Shanks for Square Shank Tools

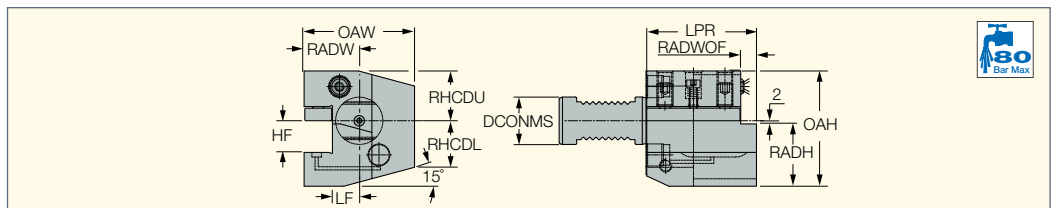

Designation	DCONMS	HF	LPR	OAW	RADW	LF	RADWOF	RHCDL	RHCDU	RADH	OAH	DCP ⁽¹⁾
VDI16 C2C3A-161244-JHPMC	16.00	12.0	44.00	43.00	24.00	13.00	5.00	15.00	15.00	23.00	45.00	0
VDI25 C2C3A-252055-JHPMC	25.00	20.0	55.00	52.00	37.00	15.00	7.00	38.00	38.00	36.00	66.00	0
VDI30 C2C3A-302070-JHPMC	30.00	20.0	70.00	76.00	41.00	17.00	10.00	26.00	26.00	38.00	70.00	0
VDI40 C2C3A-402585-JHPMC	40.00	25.0	85.00	90.00	47.50	21.00	12.50	35.00	30.00	48.00	86.00	0
VDI50 C2C3A-502585-JHPMC	50.00	25.0	85.00	95.00	52.50	26.00	12.50	42.00	37.00	48.00	92.00	0

- Form C2 axial L.H., form C3 axial overhead R.H. short.
- (1) 1 - Slot for data chip, 0 - Without slot for data chip

TOOL BLOCKS

VDI-C2/C3AK-JHPMC
Axially Oriented, Short, Left-Hand, Wedge Clamping Holders with VDI DIN69880 Shanks for Square Shank Tools

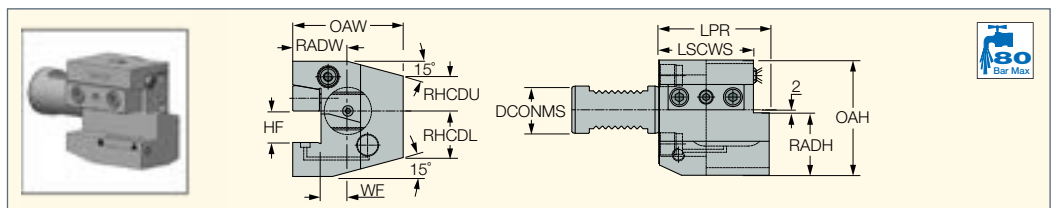

Designation	DCONMS	HF	LPR	LSCWS	OAW	RADW	WF	RHCDL	RHCDU	RADH	OAH	DCP ⁽¹⁾
VDI30 C2C3AK-302070-JHPMC	30.00	20.0	70.00	60.00	76.00	41.00	23.00	26.00	22.00	38.00	70.00	0
VDI40 C2C3AK-402585-JHPMC	40.00	25.0	85.00	72.50	90.00	47.50	25.50	35.00	30.00	48.00	86.00	0
VDI50 C2C3AK-502585-JHPMC	50.00	25.0	85.00	72.50	95.00	52.50	30.50	42.00	35.00	48.00	92.00	0

- Form C2 axial L.H., form C3 axial overhead R.H. short.
- (1) 1 - Slot for data chip, 0 - Without slot for data chip

DIN69880-HYDRO

Hydraulic Chucks with VDI Shanks, for Semi-Finish and Finish Applications

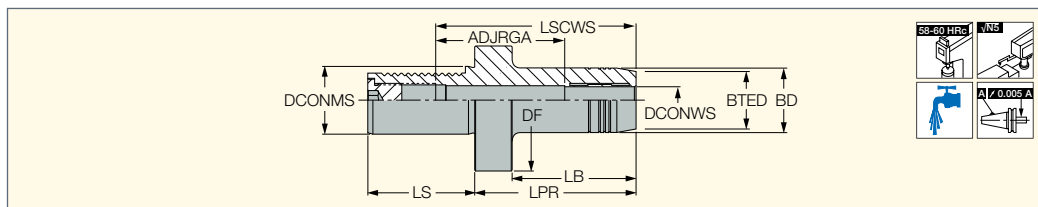

Designation	DCONMS	BTED	BD	DF	DCONWS	LS	LPR	LB	ADJRGA	LSCWS	
DIN69880 30 HYDRO 20X89	30.00	38.00	42.00	68.00	20.00	55.00	95.00	73.0	37.00	85.0	1.24
DIN69880 30 HYDRO 25X100	30.00	46.00	50.00	68.00	25.00	55.00	100.00	84.0	31.00	85.0	1.20
DIN69880 40 HYDRO 20X95	40.00	38.00	42.00	83.00	20.00	63.00	95.00	73.0	82.00	130.0	2.00
DIN69880 40 HYDRO 25X95	40.00	46.00	50.00	83.00	25.00	63.00	95.00	73.0	76.00	130.0	2.14
DIN69880 40 HYDRO 32X95	40.00	56.00	60.00	83.00	32.00	63.00	95.00	73.0	32.00	90.0	2.00

- Chucking forces will be reduced by 25% if reduction sleeves are used
- Reduction sleeves are available for 12, 20, 25 and 32 mm bore diameters (ordered separately)
- Clamping wrench (wrench HYDRO HEX 4) and test bar should be ordered separately

Spare Parts

Designation			
DIN69880 30 HYDRO 20X89	HYDRO CLAMP SCREW M8X14	WRENCH HYDRO HEX 4*	TEST BAR HYDRO 20*
DIN69880 30 HYDRO 25X100	HYDRO CLAMP SCREW M8X14	WRENCH HYDRO HEX 4*	TEST BAR HYDRO 25*
DIN69880 40 HYDRO 20X95	HYDRO CLAMP SCREW M8X14	WRENCH HYDRO HEX 4*	TEST BAR HYDRO 20*
DIN69880 40 HYDRO 25X95	HYDRO CLAMP SCREW M8X14	WRENCH HYDRO HEX 4*	TEST BAR HYDRO 25*
DIN69880 40 HYDRO 32X95	HYDRO CLAMP SCREW M8X14	WRENCH HYDRO HEX 4*	TEST BAR HYDRO 32*

* Optional, to be ordered separately

WHISPERLINE

VDI AV-JHP

VDI Holders For Anti-Vibration Tools

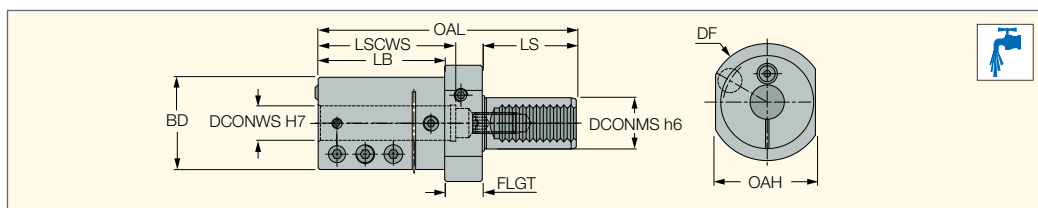

Designation	DCONMS	DCONWS	OAL	LS	BD	DF	LSCWS	LB	FLGT	OAH
VDI30 AV-D16-JHP	30.00	16.00	143.00	55.0	50.00	68.00	70.00	66.0	22.00	56.00
VDI30 AV-D20-JHP	30.00	20.00	151.00	55.0	54.00	68.00	80.00	74.0	22.00	56.00
VDI30 AV-D25-JHP	30.00	25.00	167.00	55.0	58.00	68.00	100.00	90.0	22.00	56.00
VDI30 AV-D32-JHP	30.00	32.00	197.00	55.0	63.00	68.00	128.00	120.0	22.00	56.00
VDI40 AV-D16-JHP	40.00	16.00	151.00	63.0	50.00	83.00	70.00	66.0	22.00	65.00
VDI40 AV-D20-JHP	40.00	20.00	159.00	63.0	54.00	83.00	80.00	74.0	22.00	65.00
VDI40 AV-D25-JHP	40.00	25.00	175.00	63.0	58.00	83.00	100.00	90.0	22.00	65.00
VDI40 AV-D32-JHP	40.00	32.00	205.00	63.0	63.00	83.00	128.00	120.0	22.00	65.00
VDI40 AV-D40-JHP	40.00	40.00	237.00	63.0	73.00	83.00	150.00	152.0	22.00	65.00
VDI50 AV-D16-JHP	50.00	16.00	181.00	78.0	50.00	98.00	85.00	81.0	22.00	70.00
VDI50 AV-D20-JHP	50.00	20.00	181.00	78.0	54.00	98.00	89.00	73.0	30.00	70.00
VDI50 AV-D25-JHP	50.00	25.00	198.00	78.0	59.00	98.00	106.00	90.0	30.00	70.00
VDI50 AV-D32-JHP	50.00	32.00	228.00	78.0	65.00	98.00	128.00	120.0	30.00	70.00
VDI50 AV-D40-JHP	50.00	40.00	260.00	78.0	73.00	98.00	160.00	152.0	30.00	70.00
VDI50 AV-D50-JHP	50.00	50.00	260.00	78.0	83.00	98.00	160.00	152.0	30.00	70.00
VDI60 AV-D25-JHP	60.00	25.00	214.00	94.0	59.00	123.00	106.00	90.0	30.00	85.00
VDI60 AV-D32-JHP	60.00	32.00	244.00	94.0	65.00	123.00	128.00	120.0	30.00	85.00
VDI60 AV-D40-JHP	60.00	40.00	276.00	94.0	73.00	123.00	160.00	152.0	30.00	85.00
VDI60 AV-D50-JHP	60.00	50.00	296.00	94.0	83.00	123.00	180.00	172.0	30.00	85.00
VDI60 AV-D60-JHP	60.00	60.00	296.00	94.0	102.00	123.00	180.00	172.0	30.00	85.00

WHISPERLINE

BLKT AV-JHP
BLKT Sleeve Type Blocks
for DMG Machines

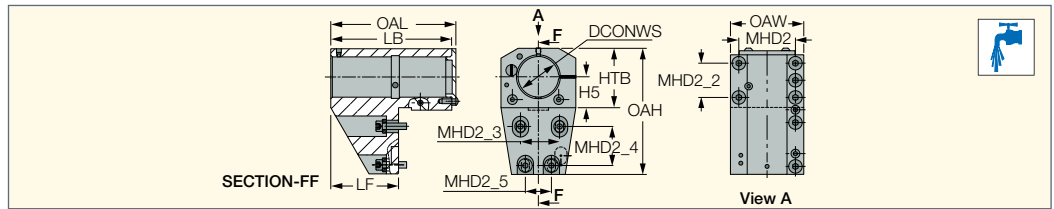

Designation	DCONWS	OAW	OAH	OAL	H5	LB	LF	HTB	MHD2	MHD2_2	MHD2_3	MHD2_4	MHD2_5
BLKT AV-2540-JHP	40.00	92.00	145.00	145.00	30.00	140.00	74.00	63.0	71.0	43.0	48.0	48.0	32.0
BLKT AV-3240-JHP	40.00	135.00	172.00	145.00	40.00	140.00	58.00	75.0	115.0	63.0	50.0	63.0	50.0
BLKT AV-3250-JHP	50.00	135.00	172.00	155.00	40.00	150.00	68.00	75.0	115.0	63.0	50.0	63.0	50.0
BLKT AV-3260-JHP	60.00	135.00	177.00	165.00	40.00	160.00	78.00	80.0	115.0	63.0	50.0	63.0	50.0
BLKT AV-3280-JHP	80.00	134.00	179.00	185.00	50.00	180.00	98.00	100.0	115.0	63.0	50.0	63.0	50.0

WHISPERLINE

AV FLEX-SLEEVE
Reduction Sleeves for Tool
Blocks and VDI Holders

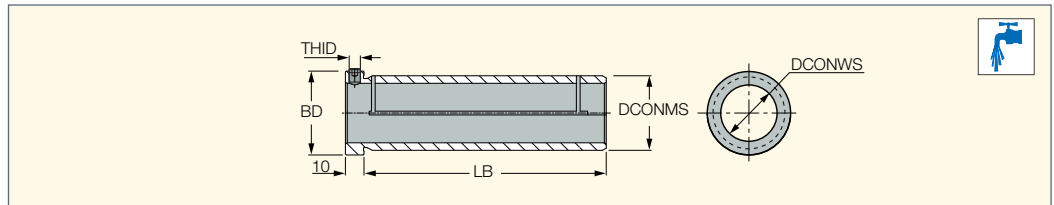

Designation	DCONMS	DCONWS	BD	LB	THID
RED PU1S-AV-3225	32.00	25.00	37.00	115.00	M6
RED PU1S-AV-4032	40.00	32.00	45.00	127.00	M6
RED PU1S-AV-5040	50.00	40.00	55.00	127.00	M6
RED PU1S-AV-6050	60.00	50.00	65.00	154.00	M6

WHISPERLINE

AV-BUSH
Reduction Sleeves for Tool
Blocks and VDI Holders

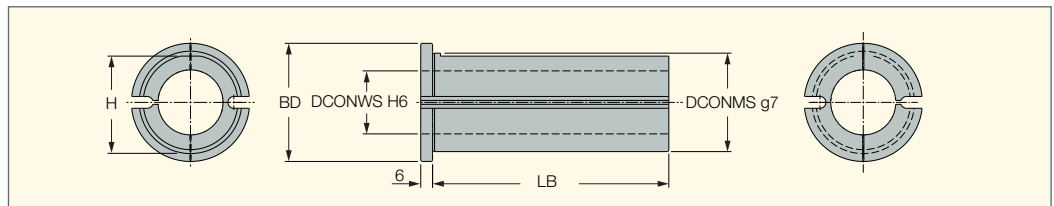

Designation	DCONMS	DCONWS	BD	LB	H
AV-BUSH-32-16	32.00	16.00	42.00	60.00	31.0
AV-BUSH-32-20	32.00	20.00	42.00	60.00	31.0
AV-BUSH-32-25	32.00	25.00	42.00	60.00	31.0
AV-BUSH-40-16	40.00	16.00	50.00	100.00	38.5
AV-BUSH-40-20	40.00	20.00	50.00	100.00	38.5
AV-BUSH-40-25	40.00	25.00	50.00	100.00	38.5
AV-BUSH-40-32	40.00	32.00	50.00	100.00	38.5
AV-BUSH-50-20	50.00	20.00	60.00	120.00	48.5
AV-BUSH-50-25	50.00	25.00	60.00	120.00	48.5
AV-BUSH-50-32	50.00	32.00	60.00	120.00	48.5
AV-BUSH-50-40	50.00	40.00	60.00	120.00	48.5
AV-BUSH-60-32	60.00	32.00	70.00	150.00	58.5
AV-BUSH-60-40	60.00	40.00	70.00	150.00	58.5
AV-BUSH-60-50	60.00	50.00	70.00	150.00	58.5

NEW



Straight Shank

ST-ER

DIN 6499 ER Collet Chucks with Straight Shanks

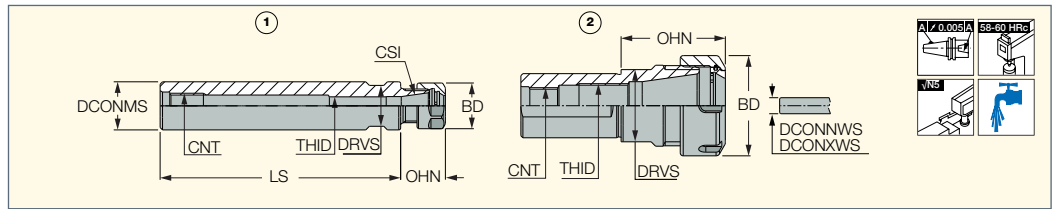

Designation	DCONMS	CSI	DCONNWS ⁽¹⁾	DCONXWS ⁽²⁾	LS	OHN ⁽³⁾	CNT	THID	BD	DRVS ⁽⁴⁾	Fig.	kg
ST 16X 50 ER11 F	16.00	ER11	0.50	7.00	50.0	18.5	G1/8	M7.5X0.5	19.00	13.0	1.	0.06
ST 20X 50 ER11 F	20.00	ER11	0.50	7.00	50.0	18.5	G1/8	M7.5X0.5	19.00	17.0	1.	0.10
ST 20X100 ER11	20.00	ER11	0.50	7.00	100.0	18.5	G1/8	M7.5X0.5	19.00	17.0	1.	0.20
ST 20X150 ER11	20.00	ER11	0.50	7.00	150.0	18.5	-	M10	19.00	17.0	1.	0.25
ST 20X 50 ER16 F	20.00	ER16	0.50	10.00	50.0	32.3	-	M12	28.00	19.0	1.	0.07
ST 20X100 ER16	20.00	ER16	0.50	10.00	100.0	30.0	-	M12	28.00	19.0	1.	0.20
ST 20X100 ER16 F	20.00	ER16	0.50	10.00	100.0	30.0	-	M12	28.00	19.0	1.	0.20
ST 20X150 ER16	20.00	ER16	0.50	10.00	150.0	30.0	-	M12	28.00	19.0	1.	0.28
ST 20X 50 ER20 F	20.00	ER20	1.00	13.00	50.0	42.5	-	M12	34.00	22.0	1.	0.15
ST 25X100 ER20	25.00	ER20	1.00	13.00	100.0	36.0	G1/4	M14X1	34.00	22.0	1.	0.30
ST 25X150 ER20	25.00	ER20	1.00	13.00	150.0	36.0	-	M16	34.00	22.0	1.	0.39
ST 20X 50 ER25 F	20.00	ER25	1.00	16.00	50.0	46.0	G1/8	M14X1	42.00	28.0	2.	0.21
ST 20X100 ER25	20.00	ER25	1.00	16.00	100.0	46.0	-	M12	42.00	28.0	2.	0.29
ST 20X100 ER25 F	20.00	ER25	1.00	16.00	100.0	46.0	-	M12	42.00	28.0	2.	0.09
ST 25X 50 ER25 F	25.00	ER25	1.00	16.00	50.0	46.0	G1/4	M18X1	42.00	28.0	2.	0.22
ST 25X100 ER25	25.00	ER25	1.00	16.00	100.0	46.0	-	M16	42.00	28.0	2.	0.36
ST 20X 50 ER32 F	20.00	ER32	2.00	20.00	50.0	54.0	G1/8	M14X1	50.00	36.0	2.	0.30
ST 20X100 ER32	20.00	ER32	2.00	20.00	100.0	54.0	G1/8	M14X1	50.00	36.0	2.	0.40
ST 25X 50 ER32 F	25.00	ER32	2.00	20.00	50.0	52.0	G1/4	M18X1	50.00	36.0	2.	0.32
ST 30X 50 ER32 F	30.00	ER32	2.00	20.00	50.0	52.0	G1/4	M22X1.5	50.00	36.0	2.	0.39
ST 32X 50 ER32 F	32.00	ER32	2.00	20.00	50.0	52.0	G1/4	M22X1.5	50.00	36.0	2.	0.42
ST 32X150 ER32	32.00	ER32	2.00	20.00	150.0	52.0	G1/4	M22X1.5	50.00	36.0	2.	0.88
ST 40X 75 ER32 F	40.00	ER32	2.00	20.00	75.0	46.0	-	M22X1.5	50.00	44.0	2.	0.72
ST 25X 50 ER40 F	25.00	ER40	3.00	26.00	50.0	60.0	-	M16X2	63.00	45.0	2.	0.52
ST 30X 50 ER40 F	30.00	ER40	3.00	26.00	50.0	60.0	-	M18X1.5	63.00	45.0	2.	0.57
ST 32X 50 ER40 F	32.00	ER40	3.00	26.00	50.0	60.0	-	M18X1.5	63.00	45.0	2.	0.60
ST 40X 75 ER40 F	40.00	ER40	3.00	26.00	75.0	55.0	-	M22X1.5	63.00	45.0	2.	0.84
ST 50X 80 ER40 F	50.00	ER40	3.00	26.00	80.0	60.0	-	M28X1.5	63.00	54.0	2.	1.30
ST 50X 80 ER50 F	50.00	ER50	10.00	34.00	80.0	77.0	-	M36X1.5	78.00	58.0	2.	1.32





(1) Minimum diameter

(2) Maximum diameter

(3) Minimum overhang

(4) Torque key size

Spare Parts

Designation				
ST 16X 50 ER11 F	NUT ER11 UM	WRENCH ER11*	PRESET ER-JET 8X1.25*	
ST 20X 50 ER11 F	NUT ER11 UM	WRENCH ER11*	PRESET ER-JET 10X1.5*	
ST 20X100 ER11	NUT ER11 UM	WRENCH ER11*	PRESET ER-JET 10X1.5*	
ST 20X150 ER11	NUT ER11 UM	WRENCH ER11*	PRESET ER-JET 10X1.5*	
ST 20X 50 ER16 F	NUT ER16 TOP	WRENCH ER16*	PRESET ER-JET 12X1.75*	PRESET ER-JET 12X1.75L*
ST 20X100 ER16	NUT ER16 TOP	WRENCH ER16*	PRESET ER-JET 12X1.75*	PRESET ER-JET 12X1.75L*
ST 20X100 ER16 F	NUT ER16 TOP	WRENCH ER16*	PRESET ER-JET 12X1.75*	PRESET ER-JET 12X1.75L*
ST 20X150 ER16	NUT ER16 TOP	WRENCH ER16*	PRESET ER-JET 12X1.75*	PRESET ER-JET 12X1.75L*
ST 20X 50 ER20 F	NUT ER20 TOP	WRENCH ER20*	PRESET ER-JET 12X1.75*	PRESET ER-JET 12X1.75L*
ST 25X100 ER20	NUT ER20 TOP	WRENCH ER20*	PRESET ER-JET 16X2*	PRESET ER-JET 16X2L*
ST 25X150 ER20	NUT ER20 TOP	WRENCH ER20*	PRESET ER-JET 16X2*	PRESET ER-JET 16X2L*
ST 20X 50 ER25 F	NUT ER25 TOP	WRENCH ER25*	PRESET ER-JET 12X1.75*	PRESET ER-JET 12X1.75L*
ST 20X100 ER25	NUT ER25 TOP	WRENCH ER25*	PRESET ER-JET 12X1.75*	PRESET ER-JET 12X1.75L*
ST 20X100 ER25 F	NUT ER25 TOP	WRENCH ER25*	PRESET ER-JET 12X1.75*	PRESET ER-JET 12X1.75L*
ST 25X 50 ER25 F	NUT ER25 TOP	WRENCH ER25*	PRESET ER-JET 16X2*	PRESET ER-JET 16X2L*
ST 25X100 ER25	NUT ER25 TOP	WRENCH ER25*	PRESET ER-JET 16X2*	PRESET ER-JET 16X2L*
ST 20X 50 ER32 F	NUT ER32 TOP	WRENCH ER32*	PRESET ER-JET 12X1.75*	PRESET ER-JET 12X1.75L*
ST 20X100 ER32	NUT ER32 TOP	WRENCH ER32*	PRESET ER-JET 12X1.75*	PRESET ER-JET 12X1.75L*
ST 25X 50 ER32 F	NUT ER32 TOP	WRENCH ER32*	PRESET ER-JET 16X2*	PRESET ER-JET 16X2L*
ST 30X 50 ER32 F	NUT ER32 TOP	WRENCH ER32*	PRESET ER-JET 18X1.5*	PRESET ER-JET 18X1.5L*
ST 32X 50 ER32 F	NUT ER32 TOP	WRENCH ER32*	PRESET ER-JET 18X1.5*	PRESET ER-JET 18X1.5L*
ST 32X150 ER32	NUT ER32 TOP	WRENCH ER32*	PRESET ER-JET 18X1.5*	PRESET ER-JET 18X1.5L*
ST 40X 75 ER32 F	NUT ER32 TOP	WRENCH ER32*	PRESET ER-JET 22X1.5*	PRESET ER-JET 22X1.5L*
ST 25X 50 ER40 F	NUT ER40 TOP	WRENCH ER40*	PRESET ER-JET 16X2*	PRESET ER-JET 16X2L*
ST 30X 50 ER40 F	NUT ER40 TOP	WRENCH ER40*	PRESET ER-JET 18X1.5*	PRESET ER-JET 18X1.5L*
ST 32X 50 ER40 F	NUT ER40 TOP	WRENCH ER40*	PRESET ER-JET 18X1.5*	PRESET ER-JET 18X1.5L*
ST 40X 75 ER40 F	NUT ER40 TOP	WRENCH ER40*	PRESET ER-JET 22X1.5*	PRESET ER-JET 22X1.5L*
ST 50X 80 ER40 F	NUT ER40 TOP	WRENCH ER40*	PRESET ER-JET 28X1.5*	
ST 50X 80 ER50 F	NUT ER50 UM	WRENCH ER50*		

* Optional, to be ordered separately

Straight Shank

ST-ER-MF (mini flat)
 DIN 6499 ER Mini Collet
 Chucks with Cylindrical
 Shanks and a Clamping Flat
 for Swiss-Type CNC Lathes

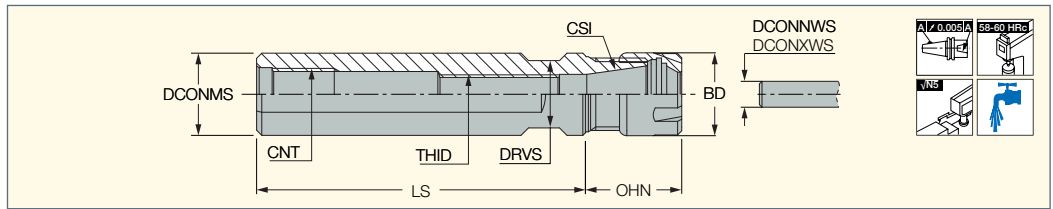

Designation	DCONMS	CSI	LS	DCONNWS ⁽⁶⁾	DCONXWS ⁽⁷⁾	OHN ⁽⁸⁾	CNT	THID	BD	DRVS ⁽⁹⁾	
ST 16X 38 ER11 MF ⁽¹⁾	16.00	ER11	38.00	0.5	7.0	18.50	-	M8X1	16.00	14.0	0.05
ST 16X 50 ER11 MF	16.00	ER11	50.00	0.5	7.0	18.50	G1/8	M7.5X0.5	16.00	13.0	0.07
ST 16X140 ER11 MF	16.00	ER11	140.00	0.5	7.0	18.50	G1/8	M7.5X0.5	16.00	14.0	0.18
ST 16X 35 ER16 MF ⁽¹⁾	16.00	ER16	35.00	0.5	10.0	36.00	-	M8X1	22.00	17.0	0.08
ST 20X 50 ER16 MF ⁽²⁾	20.00	ER16	50.00	0.5	10.0	26.00	G1/8	M11X1	22.00	17.0	0.10
ST 20X 70 ER16 MF ⁽²⁾	20.00	ER16	70.00	0.5	10.0	26.00	G1/8	M11X1	22.00	17.0	0.17
ST 20X120 ER16 MF ⁽²⁾	20.00	ER16	120.00	0.5	10.0	26.00	G1/8	M11X1	22.00	17.0	0.19
ST 20X140 ER16 MF ⁽²⁾	20.00	ER16	140.00	0.5	10.0	26.00	G1/8	M11X1	22.00	17.0	0.40
ST 22X 38 ER16 MF ⁽¹⁾	22.00	ER16	38.00	0.5	10.0	26.00	-	M12X1	22.00	19.0	0.10
ST 22X 70 ER16 MF ⁽¹⁾	22.00	ER16	70.00	0.5	10.0	26.00	G1/4	M11X1	22.00	19.0	0.16
ST 22X100 ER16 MF ⁽¹⁾	22.00	ER16	100.00	0.5	10.0	28.00	-	M12X1	22.00	19.0	0.23
ST 22X 80 ER20 MF ⁽¹⁾	22.00	ER20	80.00	1.0	13.0	39.00	-	M12X1	28.00	21.0	0.21
ST 22X 70 ER25 MF ⁽¹⁾	22.00	ER25	70.00	1.0	16.0	47.00	-	M12X1	35.00	27.0	0.25
ST 25X 65 ER16 MF	25.00	ER16	65.00	0.5	10.0	28.00	-	M12X1	22.00	22.0	0.22
ST 25X100 ER20 MF ⁽³⁾	25.00	ER20	100.00	1.0	13.0	28.00	-	M14X1	28.00	22.0	0.15
ST 25X154 ER20 MF ⁽³⁾	25.00	ER20	154.00	1.0	13.0	28.00	-	M14X1	28.00	22.0	0.40
ST 25X 75 ER25 MF ⁽⁴⁾	25.00	ER25	75.00	1.0	16.0	48.00	-	M14X1	35.00	27.0	0.30
ST 25X145 ER25 MF ⁽³⁾	25.00	ER25	145.00	1.0	16.0	36.00	-	M14X1	35.00	27.0	0.08
ST 32X 70 ER25 MF ⁽⁵⁾	32.00	ER25	70.00	1.0	16.0	30.00	G1/4	M18X1	35.00	27.0	0.35

- (1) For Star machines
- (2) For Citizen machines
- (3) For Tornos-Bechler machines
- (4) For Manurhin machines
- (5) For Schutte machines
- (6) Minimum diameter
- (7) Maximum diameter
- (8) Minimum overhang
- (9) Torque key size

Spare Parts

Designation			
ST 16X 38 ER11 MF	NUT ER11 MINI	WRENCH ER11 MINI*	PRESET ER-JET 8X1*
ST 16X 50 ER11 MF	NUT ER11 MINI	WRENCH ER11 MINI*	PRESET ER-JET 8X1*
ST 16X140 ER11 MF	NUT ER11 MINI	WRENCH ER11 MINI*	PRESET ER-JET 8X1*
ST 16X 35 ER16 MF	NUT ER16 MINI	WRENCH ER16 MINI*	PRESET ER-JET 8X1*
ST 20X 50 ER16 MF	NUT ER16 MINI	WRENCH ER16 MINI*	PRESET ER-JET 12X1*
ST 20X 70 ER16 MF	NUT ER16 MINI	WRENCH ER16 MINI*	PRESET ER-JET 12X1*
ST 20X120 ER16 MF	NUT ER16 MINI	WRENCH ER16 MINI*	PRESET ER-JET 12X1*
ST 20X140 ER16 MF	NUT ER16 MINI	WRENCH ER16 MINI*	PRESET ER-JET 12X1*
ST 22X 38 ER16 MF	NUT ER16 MINI	WRENCH ER16 MINI*	PRESET ER-JET 12X1*
ST 22X 70 ER16 MF	NUT ER16 MINI	WRENCH ER16 MINI*	PRESET ER-JET 12X1*
ST 22X100 ER16 MF	NUT ER16 MINI	WRENCH ER16 MINI*	PRESET ER-JET 12X1*
ST 22X 80 ER20 MF	NUT ER20 MINI	WRENCH ER20 MINI*	PRESET ER-JET 12X1*
ST 22X 70 ER25 MF	NUT ER25 MINI	WRENCH ER25 MINI*	PRESET ER-JET 12X1*
ST 25X 65 ER16 MF	NUT ER16 MINI	WRENCH ER16 MINI*	PRESET ER-JET 12X1*
ST 25X100 ER20 MF	NUT ER20 MINI	WRENCH ER20 MINI*	PRESET ER-JET 14X1*
ST 25X154 ER20 MF	NUT ER20 MINI	WRENCH ER20 MINI*	PRESET ER-JET 14X1*
ST 25X 75 ER25 MF	NUT ER25 MINI	WRENCH ER25 MINI*	PRESET ER-JET 14X1*
ST 25X145 ER25 MF	NUT ER25 MINI	WRENCH ER25 MINI*	PRESET ER-JET 14X1*
ST 32X 70 ER25 MF	NUT ER25 MINI	WRENCH ER25 MINI*	PRESET ER-JET 18X1*

* Optional, to be ordered separately

Straight Shank

ST-ER-MF-D (double-ended)

Double-Ended Mini Collets with Cylindrical Shanks and a Clamping Flat

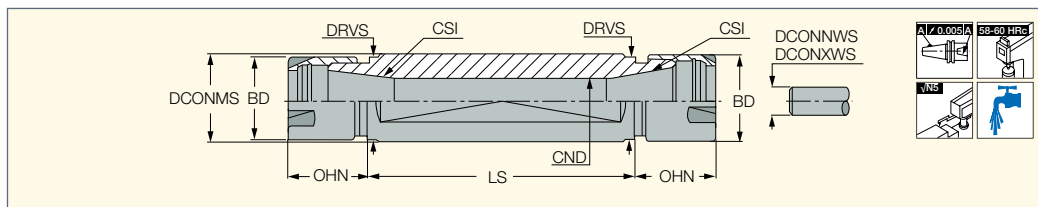

Designation	DCONMS	LS	CSI	DCONNWS ⁽³⁾	DCONXWS ⁽⁴⁾	BD	CND ⁽⁵⁾	OHN ⁽⁶⁾	DRVS ⁽⁷⁾	
ST 16X 50 ER11 MF D	16.00	50.00	ER11	0.5	7.0	16.00	7.5	18.50	14.0	0.07
ST 20X 30 ER11 MF D ⁽¹⁾	20.00	30.00	ER11	0.5	7.0	16.00	7.5	18.50	17.0	0.09
ST 20X 50 ER11 MF D ⁽¹⁾	20.00	50.00	ER11	0.5	7.0	16.00	7.5	18.50	17.0	0.13
ST 20X 55 ER16 MF D ⁽¹⁾	20.00	55.00	ER16	0.5	10.0	22.00	10.5	25.00	17.0	0.12
ST 22X 55 ER16 MF D ⁽²⁾	22.00	55.00	ER16	0.5	10.0	22.00	10.5	28.00	19.0	0.17
ST 22X 75 ER16 MF D ⁽²⁾	22.00	75.00	ER16	0.5	10.0	22.00	10.5	28.00	19.0	0.21
ST 25X 62 ER16 MF D	25.00	62.00	ER16	0.5	10.0	22.00	10.5	28.00	22.0	0.23
ST 32X 55 ER20 MF D ⁽²⁾	32.00	55.00	ER20	1.0	13.0	28.00	13.5	28.00	27.0	0.34
ST 32X 75 ER20 MF D ⁽²⁾	32.00	75.00	ER20	1.0	13.0	28.00	13.5	28.00	27.0	0.44

⁽¹⁾ For Citizen machines

⁽²⁾ For Star machines

⁽³⁾ Minimum diameter

⁽⁴⁾ Maximum diameter

⁽⁵⁾ Coolant entry diameter

⁽⁶⁾ Minimum overhang

⁽⁷⁾ Torque key size

Spare Parts

Designation		
ST 16X 50 ER11 MF D	NUT ER11 MINI	WRENCH ER11 MINI*
ST 20X 30 ER11 MF D	NUT ER11 MINI	WRENCH ER11 MINI*
ST 20X 50 ER11 MF D	NUT ER11 MINI	WRENCH ER11 MINI*
ST 20X 55 ER16 MF D	NUT ER16 MINI	WRENCH ER16 MINI*
ST 22X 55 ER16 MF D	NUT ER16 MINI	WRENCH ER16 MINI*
ST 22X 75 ER16 MF D	NUT ER16 MINI	WRENCH ER16 MINI*
ST 25X 62 ER16 MF D	NUT ER16 MINI	WRENCH ER16 MINI*
ST 32X 55 ER20 MF D	NUT ER20 MINI	WRENCH ER20 MINI*
ST 32X 75 ER20 MF D	NUT ER20 MINI	WRENCH ER20 MINI*

* Optional, to be ordered separately

Straight Shank

GFI ST-ER

Floating Reamer DIN 6499
Collet Chucks and Cylindrical
Shanks with a Clamping Flat

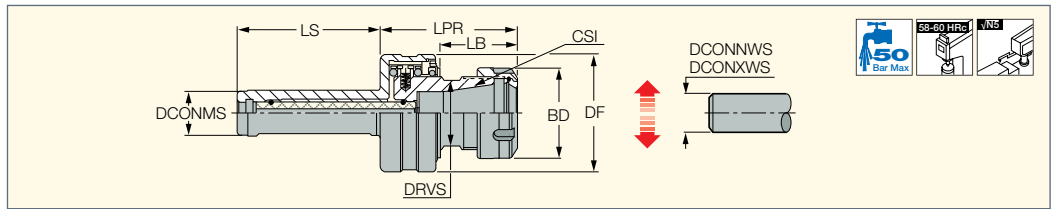

Designation	DCONMS	CSI	DCONNWS ⁽²⁾	DCONXWS ⁽³⁾	LS	LPR	LB	BD	DF	RFI	DRVS ⁽⁴⁾	
GFI ST20 ER20 ⁽¹⁾	20.00	ER20	1.0	13.0	65.00	55.50	31.0	34.00	50.00	0.50	22.0	0.56
GFI ST25 ER32 ⁽¹⁾	25.00	ER32	2.0	20.0	80.00	76.90	45.9	50.00	65.00	0.80	36.0	1.20

- Maximum 2000 RPM!
- ⁽¹⁾ Radial float from center
- ⁽²⁾ Minimum diameter
- ⁽³⁾ Maximum diameter
- ⁽⁴⁾ Torque key size

GFI ER - Floating Reamer Collet Chuck

Floating chuck - adjusts the misalignment between the reamer and workpiece hole to ensure the same accuracy as the reamer itself.

Application:

The **GFI** floating chuck is a unique holder that compensates for the radial misalignment existing in reaming operations carried out on vertical and horizontal machine tools.

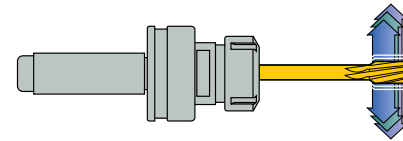
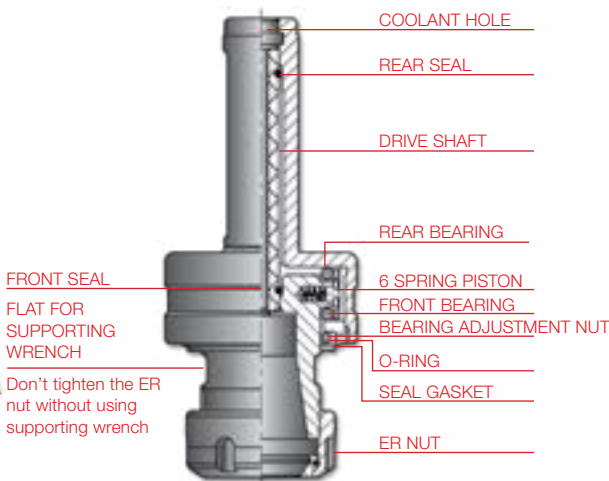

Features:

Radial self-floating mechanism compensates for misalignment between the reamer and workpiece to ensure the same tolerance as the reamer itself. The special self-centering mechanism eliminates tapered and oversized bores.

Advantages:

Unique ball bearing and axle drive shaft structure enables vertical and horizontal machining.
Precise and efficient clamping with ER spring collets or ER Coolit collets.

Spare Parts

Designation		
GFI ST20 ER20	NUT ER20 TOP	WRENCH ER20*
GFI ST25 ER32	NUT ER32 TOP	WRENCH ER32*

* Optional, to be ordered separately

MODULAR-GRIP ADAPTATIONS

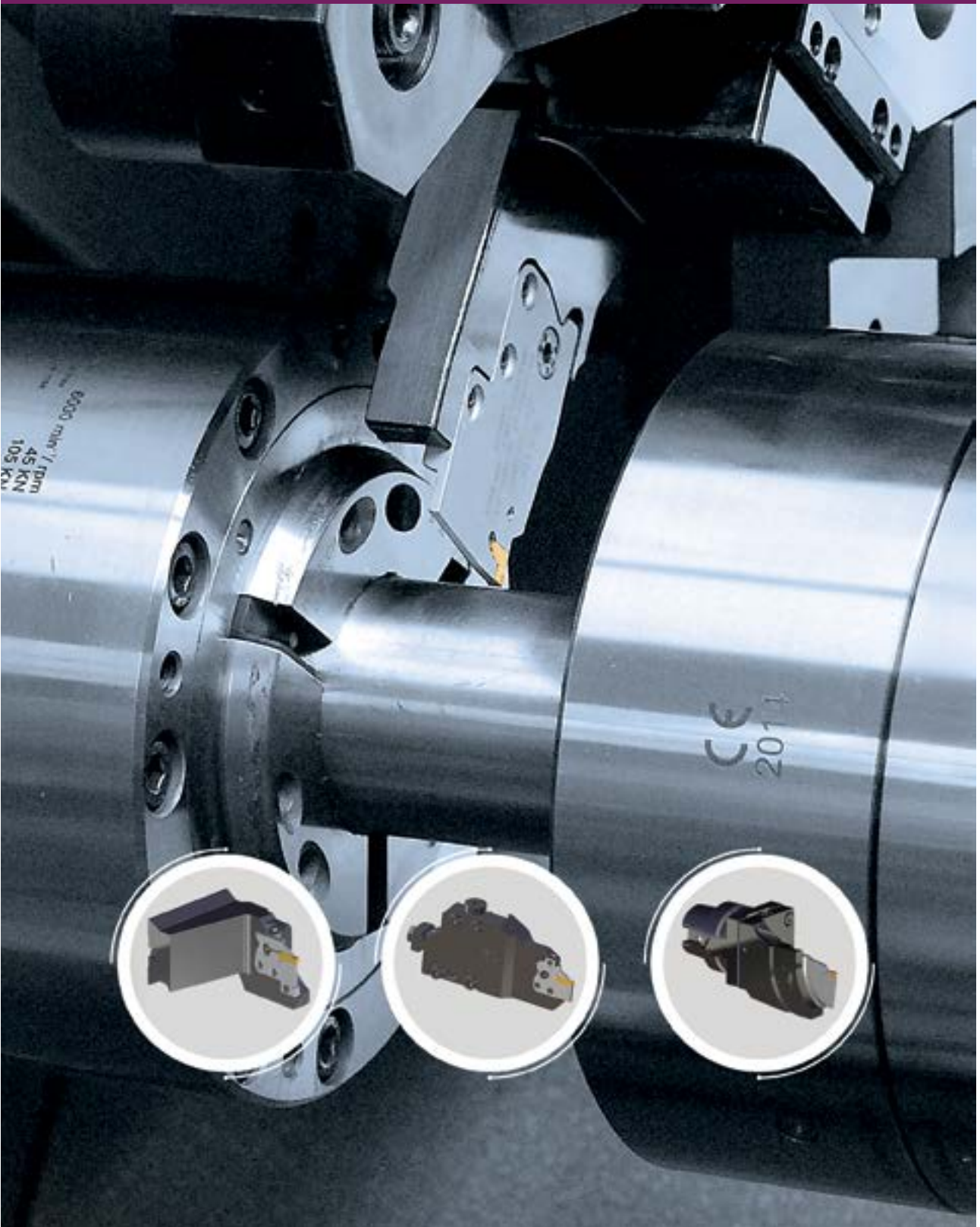

Modular-Grip Adaptations

Modular Adaptation Systems for Turning Lathes and Multi-Spindle Machine Tools Carrying ISCAR's MODULAR-GRIP Adapters Featuring Directed Internal Coolant Channels

Product Features

- The unique combination of a rigid tool and efficient coolant improves the insert's tool life, surface finish and part straightness
- Designed for high-pressure coolant up to 150 Bar and also very efficient when using low coolant pressure of 7-10 Bar
- No coolant tubes involved, which means no obstruction for chip evacuation
- Each adapter can carry several types of MODULAR-GRIP blades
- Excellent tool location repeatability after blade replacement for fast setup
- Easy and user-friendly mounting

Available adapters for the following specific machines:

- STAR
- DOOSAN / HAAS
- MAZAK
- DMG MORI
- BIGLIA / EUROTECH
- MIYANO
- NAKAMURA-TOME
- INDEX ABC
- TRAUB
- OKUMA
- TSUGAMI

Multi-Spindle machine tools

- INDEX CNC
- Schütte
- Göltenbodt



All trademarks and logos are the property of their respective companies

CONTENTS

TOOLHOLDER SYSTEMS FOR MULTI-SPINDLE MACHINES 852

Features and Benefits	852	Tool Selection	856
INDEX CNC Multi-Spindle Machines	852	INDEX CNC Multi-Spindle Machines	856
Schütte SCX CNC Multi-Spindle Machines	853	Schütte SCX CNC Multi-Spindle Machines	857
Göltenbodt GWS System	854	Göltenbodt GWS System	858
Modular-Grip Adapters with Internal Coolant	855		
		Technical Information	859
		INDEX CNC Multi-Spindle Machines	859
		Schütte SCX CNC Multi-Spindle Machines	860
		Göltenbodt GWS System	861

TOOLHOLDER SYSTEMS FOR TURNING LATHES 862

User Guide	862	Technical Information	877
ISCAR Modular System / Overview	863	VDI Tools for Disc-Type Turret	877
VDI Tools for STAR Turret	864	BMT tools for DOOSAN / HAAS Machines	877
VDI Tools for Disc-Type Turret	865	VDI Tools for STAR Turret	877
BMT Tools for DOOSAN / HAAS Machines	866	Tools for DMG MORI Machines	878
Tools for DMG MORI Machines	867	Tools for MAZAK Machines	878
Tools for MAZAK Machines	868	Tools with CAMFIX Adaptation	878
Tools with CAMFIX Adaptation	869	Tools with HSK-T Shank	878
Tools with HSK Shank	870	Tools for BIGLIA / EUROTECH Machines	879
Tools for MIYANO Machines	871	Tools for MIYANO Machines	879
Tools for BIGLIA / EUROTECH Machines	871	Tools for NAKAMURA-TOME Machines	879
Tools for NAKAMURA-TOME Machines	871	Tools for OKUMA Machines	879
Tools for INDEX ABC Machines	872	Tools for TSUGAMI Machines	879
Tools for TRAUB Machines	873	ISCAR Modular System Intermediate Holders	880
MODULAR-GRIP-XL Adaptation	874	Intermediate Holders for Square Type Adapters ..	881
Tool Design - Overview	875	Tools for TRAUB Machines	883
Tool Selection	876	Tools for INDEX ABC Machines	884

ISCAR Modular System for Multi-Spindle Machines

MODULAR-GRIP . JETCUT

Toolholder Systems for INDEX CNC Multi-Spindle Machines with MODULAR-GRIP Adaptation and Directed Internal Coolant

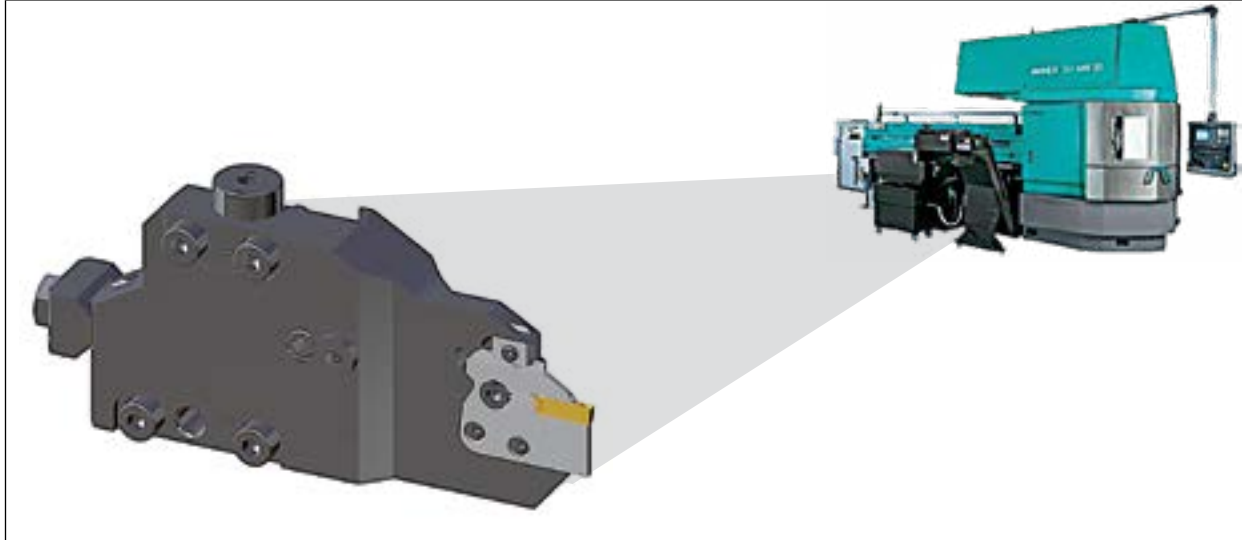

Features and Benefits of Directed Internal Coolant

	Customized to the Work Space	No Coolant Tube	Coolant Connection through the Slide	Easy Indexing
Features:	<p>Bar stopper Adapter</p>		<p>Slide</p> <p>Coolant hole</p>	
Benefits:	<ul style="list-style-type: none"> • High-end stability due to optimized holder design • No interfering contour with the sub-spindle • Reduced setup time due to fixed adapter length • Exchangeable bar stopper 	<ul style="list-style-type: none"> • Chips do not accumulate in the work space (no coolant tube/hose required) • Reliable coolant supply due to fixed flow orientation (no adjustable coolant nozzle) 	<ul style="list-style-type: none"> • No tube/hose in the work space • Reduced setup time as there are no tube/hoses to be installed 	<ul style="list-style-type: none"> • Easy handling due to clamping screw accessible from the side • Stable screw clamping

All trademarks and logos are the property of their respective companies

Toolholder Systems for Schütte CNC Multi-Spindle Machines with MODULAR-GRIP Adaptation and Directed Internal Coolant

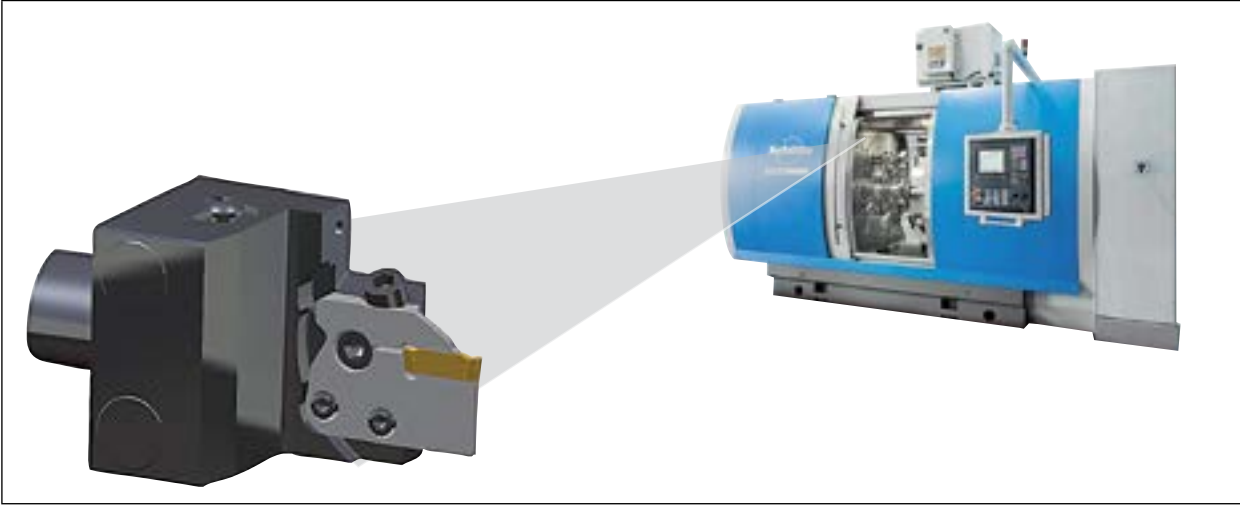

Features and Benefits of Directed Internal Coolant

	Adjustable Center Height	No Coolant Tube	Optimized Holder Design
Features			
Benefits	<ul style="list-style-type: none"> • High-end stability due to optimized holder design • No interfering contour with the sub-spindle • Reduced setup time due to fixed adapter length • Exchangeable bar stopper 	<ul style="list-style-type: none"> • Chips do not accumulate in the work space (no coolant tube/hoses required) • Reliable coolant supply due to fixed flow orientation (no free coolant nozzle) 	<ul style="list-style-type: none"> • Low risk of collision • Customized for outer diameter of the sub-spindle • Slim design • Short bar overhang

ISCAR Modular System for Multi-Spindle Machines

Toolholder Systems for Göltebott GWS Multi-Spindle Machines with MODULAR-GRIP Adaptation and Directed Internal Coolant



For various common multi-spindle machines such as:

Gildemeister	MORI-SAY.	INDEX	TORNOS and others





Features and Benefits of Directed Internal Coolant

	Matches intermediate holders with internal coolant	Coolant connection directly from the intermediate holder	Flexible system due to different adapters
Features			
Benefits	<ul style="list-style-type: none"> • Low investment • Easy switching to toolholders with internal coolant 	<ul style="list-style-type: none"> • Chips do not accumulate in the work space (no coolant tube/hose required) • Reliable coolant supply due to fixed flow orientation (no adjustable coolant nozzle) • Uninterrupted work space 	<ul style="list-style-type: none"> • Variable tool length due to different adapters • Tool length can be adjusted to the travel side

All trademarks and logos are the property of their respective companies

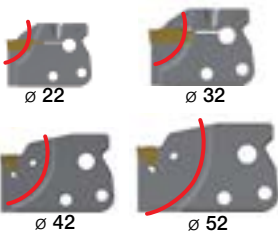
Adapters with Internal Coolant

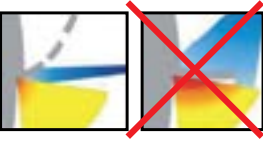
Modular-Grip Adapters with Directed Internal Coolant

	Extremely Stable	Coolant Connection from the Holder into the Adapter	Coolant / lubrication in the cutting zone	Vario System
Features	 <p> ø 22 ø 32 ø 42 ø 52 </p>			 <p> TAGPAD-JHP HGPAD-JHP DGPAD-JHP CGPAD-JHP </p>
Benefits	<ul style="list-style-type: none"> • Adapters designed for common bar diameters • Reduced vibration due to strong adapter body • Strong clamping force by screw clamping 	<ul style="list-style-type: none"> • Chips do not accumulate in the work space (no coolant tube/hose required) • No tube/hoses to be removed in case of tool breakage • Free work space 	<ul style="list-style-type: none"> • Increased tool life • Improved process safety • Better chip control 	<ul style="list-style-type: none"> • Different cutting systems can be used. Grooving and turn-groove operations can be performed with the same holder • Extremely flexible

All trademarks and logos are the property of their respective companies

Tool Selection for INDEX CNC Multi-Spindle Machines

Machine	Toolholder 	Width 	Adapter		Insert		Geometry / Feed 	Tough ← Hard			
			DGPAD 	TAGPAD 	TAG 	DGN 		IC830	IC5400	IC808	
 Index MS16	MS16- JHP	1,5 mm	DGFH MS16-1.5D16-JHP		DGN 150..J		  	low			
		2 mm	DGFH MS16-1.5D16-JHP		DGN 2002			high	•	•	•
 Index MS18	MS18- 22-MG- JHP	2 mm	DGPAD 2L-D22-JHP		DGN 2002		  	low	•	•	•
 Index MS22	MS18- 22-MG- JHP	2 mm	DGPAD 2L-D22-JHP		DGN 2002		  	low	•	•	•
 Index MS32	MS32- 40-MG- JHP	2 mm	DGPAD 2L-D32-JHP		DGN 2002		  	low	•	•	•
		3,1 mm	DGPAD 3L-D32-JHP		DGN 3102			high			
 Index MS40	MS32- 40-MG- JHP	2 mm	TAGPAD 2L-D42-JHP		TAG N2		  	low	•	•	•
		3 mm	TAGPAD 3L-D42-JHP		TAG N3			high			
 Index MS52	MS32- 40-MG- JHP oder MS52-MG-JHP	2 mm	TAGPAD 2L-D52-JHP		TAG N2		  	low	•	•	•
		3 mm	TAGPAD 3L-D52-JHP		TAG N3			high			

All trademarks and logos are the property of their respective companies

Tool Selection for Schütte CNC Multi-Spindle Machines SCX

System Size	Toolholder	Intermediate holder	Width	Adapter		Insert		Geometry / Feed	Tough ↔ Hard		
				DGPAD	TAGPAD	TAG	DGN		IC880	IC5400	IC808
 SCX-32	C3 DT30/2-L23	DT30/2 MAHDR-SCX-D80-JHP	2 mm	DGPAD 2L-D32-JHP	DGN 2002	LF	  	low			
	C4 DT30/2-L23		3,1 mm	DGPAD 3L-D32-JHP		DGN 3102		MF	high	•	•
 SCX-46	C3 DT30/2-L23	DT30/2 MAHDR-SCX-D80-JHP	2 mm	TAGPAD 2L-D52-JHP	TAG N2	LF	  	low			
	C4 DT30/2-L23		3 mm	TAGPAD 3L-D52-JHP		TAG N3		MF	high	•	•



Tool Selection for Göltebodd GWS Systems

System Size	Max. Diameter	Width of Cut (W)	Length L	Toolholder		Adapter		Insert		Geometry / Feed	Tough ↔ Hard			
				Right Hand	Left Hand	DGPAD	TAGPAD	TAG	DGN		IC830	IC5400	IC808	
	20 mm	2 mm	51 mm		MS-ES02012-GWS-MG-JHP		DGPAD 2R/ L-D20-GWS-JHP*		DGN 2002	LF	low			
			59 mm		MS-ES02013-GWS-MG-JHP									
	32 mm	2 mm	59,5 mm		MS-ES02012-GWS-MG-JHP		DGPAD 2R/ L-D32-JHP*		DGN 2002	MF	high	•	•	•
			67,5 mm		MS-ES02013-GWS-MG-JHP									
		3,1 mm	59,5 mm		MS-ES02012-GWS-MG-JHP		DGPAD 3R/ L-D32-JHP*		DGN 3102	C	high			
			67,5 mm		MS-ES02013-GWS-MG-JHP									
	20 mm	2 mm	61 mm		MS-ES09003-GWS-MG-JHP		DGPAD 2R/ L-D20-GWS-JHP*		DGN 2002	LF	low			
	32 mm	2 mm	59,5 mm		MS-ES09003-GWS-MG-JHP		DGPAD 2R/ L-D32-JHP*		DGN 2002	MF	high	•	•	•
			59,5 mm		MS-ES09003-GWS-MG-JHP		DGPAD 3R/ L-D32-JHP*		DGN 3102					
	42 mm	2 mm	62,6 mm		MS-ES09003-GWS-MG-JHP		TAGPAD 2R/ L-D42-JHP*		TAG N2	C	high			
		3 mm	62,4 mm		MS-ES09003-GWS-MG-JHP		TAGPAD 3R/ L-D42-JHP*		TAG N3					
	52 mm	2 mm	67,6 mm		MS-ES09003-GWS-MG-JHP		TAGPAD 2R/ L-D52-JHP*		TAG N2					
3 mm		67,4 mm		MS-ES09003-GWS-MG-JHP		TAGPAD 3R/ L-D52-JHP*		TAG N3						
	20 mm	2 mm	59 mm		MS-ES41008-GWS-MG-JHP	MS-ES41009-GWS-MG-JHP	DGPAD 2R/ L-D20-GWS-JHP*		DGN 2002	LF	low			
	32 mm	2 mm	67,5 mm		MS-ES41008-GWS-MG-JHP	MS-ES41009-GWS-MG-JHP	DGPAD 2R/ L-D32-JHP*		DGN 2002	MF	high	•	•	•
			67,5 mm		MS-ES41008-GWS-MG-JHP	MS-ES41009-GWS-MG-JHP	DGPAD 3R/ L-D32-JHP*		DGN 3102					
	42 mm	2 mm	70,6 mm		MS-ES41008-GWS-MG-JHP	MS-ES41009-GWS-MG-JHP	TAGPAD 2R/ L-D42-JHP*		TAG N2	C	high			
		3 mm	70,4 mm		MS-ES41008-GWS-MG-JHP	MS-ES41009-GWS-MG-JHP	TAGPAD 3R/ L-D42-JHP*		TAG N3					
	52 mm	2 mm	75,6 mm		MS-ES41008-GWS-MG-JHP	MS-ES41009-GWS-MG-JHP	TAGPAD 2R/ L-D52-JHP*		TAG N2					
3 mm		75,4 mm		MS-ES41008-GWS-MG-JHP	MS-ES41009-GWS-MG-JHP	TAGPAD 3R/ L-D52-JHP*		TAG N3						

*Selection of right hand or left hand adapter see page 861

INDEX

MODULAR-GRIP

MS##-##-MG-JHP

Toolholders for INDEX CNC Multi-Spindle Machines with Internal Coolant Supply for MODULAR-GRIP Adapters

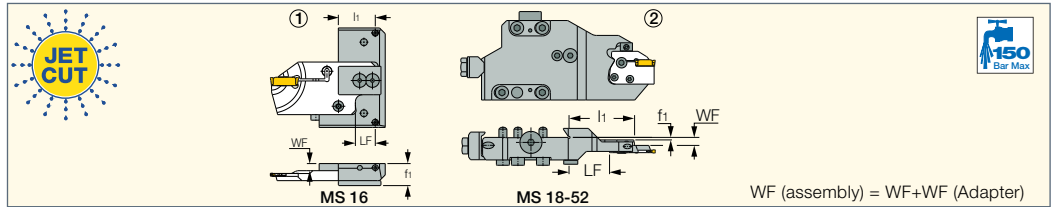

Designation	LF	l1	WF	f1	Fig.	Adapter	Adapter2
MS 16-JHP	14.00	26.00	5.00	15.5	1	DGFH MS16-1.5D16-JHP	-
MS 18/22-MG-JHP	46.20	67.00	13.60	8.1	2	DGPAD 2L-D22-JHP	-
MS 18/22-MG-JHP L-69.7	24.20	48.00	13.60	8.0	2	DGPAD 2L-D22-JHP	-
MS 32/40-MG-JHP	45.00	69.80	13.50	8.0	2	DGPAD 2/3L-D32-JHP	TAGPAD 2/3-D42-JHP
MS 32/40-MG-JHP-5.1	45.00	69.80	13.50	8.0	2	DGPAD 2/3L-D32-JHP	TAGPAD 2/3-D42-JHP
MS 32C-HUBVERL-MG-JHP	74.50	99.30	13.50	8.0	2	DGPAD 2/3L-D32-JHP	TAGPAD 2/3L-D32-JHP
MS 40-6/8-MG-JHP	55.00	79.80	13.50	8.0	2	TAGPAD 2/3L-D42-JHP	DGPAD 2/3L-D42-JHP
MS 40-6/8-MG-JHP-7.1	55.00	79.80	13.50	8.0	2	TAGPAD 2/3L-D42-JHP	DGPAD 2/3L-D42-JHP
MS 52-MG-JHP	46.60	-	4.50	-	2	TAGPAD 2/3-D52-JHP	-

• For user guide, see pages 852-858 • All trademarks and logos are the property of their respective companies

For tools, see pages: CGPAD-JHP (309) • DGPAD-D12/22-JHP (539) • DGPAD-JHP (538) • HGPAD-JHP (291) • PCADR/L-JHP (353) • PCADRS/LS-JHP (354)

• PCLNR/L-PAD-JHP (25) • PDJNR/L-PAD-JHP (38) • SCLCR/L-PAD-JHP (71) • SDJCR/L-PAD-JHP (78) • SVJCR/L-PAD-JHP (88)

• TAGPAD-JHP (562) • TGPAD-JHP (298)

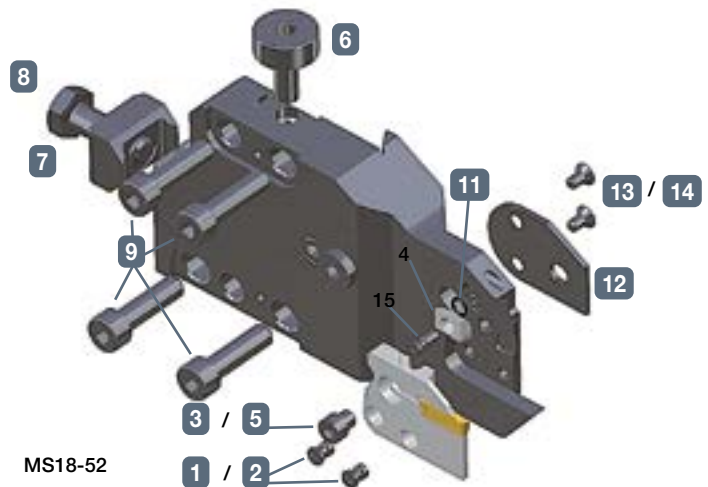
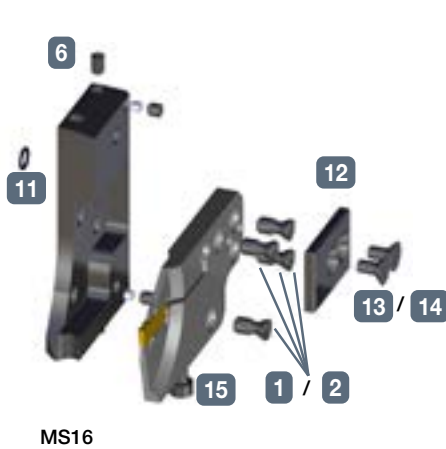

Spare Parts MS##-##-MG-JHP

No.	Designation	MS16-JHP	MS18/22-MG-JHP	MS32/40-MG-JHP
1	Screw	SR M5-04451-L10.5	SR 16-212-L7.5	SR 16-212-L7.5
2	Key	T-20/5	T-20/5	T-20/5
3	Screw		SR M6X6DIN6912-5112367	SR M6X6DIN6912-5112367
4	Wedge		KEIL 12X30DEG-5112247	KEIL 12X30DEG-5112247
5	Key		HW 5.0	HW 5.0
6	Screw	SR M4x6 DIN913 45H	WN99-08.0010.0	WN99-08.0010.0
7	Wedge		WN-11.0012.0	W00014.0017
8	ZI screw		ISO 4017-DIN 933 M8X30	ISO 4017-DIN 933 M10X30
9	Screw		SR M6X20DIN912 12.9	SR M8X30DIN912
10	Coolant Tube*		ROHR M4X1-40	ROHR M4X1-40
11	O-Ring	OR 5X1N	OR 5X1N	OR 5X1N
12	Bar stopper	W00019.0064	PLATTE-MS18-22-5112868	PLATTE-MS18-22-5112868
13	Screw	DIN7991-M4X8-8.8	DIN7991-M4X8-8.8	DIN7991-M4X8-8.8
14	Key	HW 2.5	HW 2.5	HW 2.5
15	Screw	SR M4x30DIN912	SR 34-535	SR 34-535

No.	Designation	MS32/40-MG-JHP-5.1	MS52-MG-JHP
1	Screw	SR 16-212-L7.5	SR 16-212-L7.5
2	Key	T-20/5	T-20/5
3	Screw	SR M6X6DIN6912-5112367	SR M6X6DIN6912-5112367
4	Wedge	KEIL 12X30DEG-5112247	KEIL 12X30DEG-5112247
5	Key	HW 5.0	HW 5.0
6	Screw	WN99-08.0010.0	WN99-08.0010.0
7	Wedge	W00014.0017	WN-11.0014.0
8	ZI screw	ISO 4017-DIN 933 M10X30	ISO 4017-DIN 933 M10X30
9	Screw	SR M8X30DIN912	
10	Coolant Tube*	ROHR M4X1-40	ROHR M4X1-40
11	O-Ring	OR 5X1N	OR 5X1N
12	Bar stopper	PLATTE-MS18-22-5112868	PLATTE-MS18-22-5112868*
13	Screw	DIN7991-M4X8-8.8	DIN7991-M4X8-8.8*
14	Key	HW 2.5	HW 2.5
15	Screw	SR 34-535	SR 34-535

* Optional, please order separately.

All trademarks and logos are the property of their respective companies



MODULAR-GRIP

C#-DT##/2-L23

Toolholder with CAMFIX
Adaptation on DT for
SCHUTTE Machine Tools

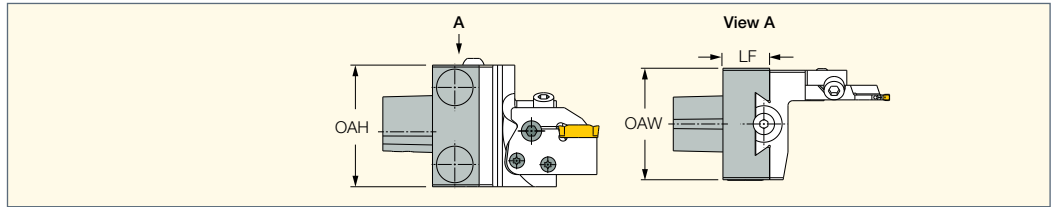

Designation	OAH	OAW	LF
C3 DT20/2-L23	57.00	45.00	23.50
C3 DT30/2-L23	60.00	55.00	23.50
C4 DT30/2-L23	60.00	55.00	23.50

• All trademarks and logos are the property of their respective companies



MODULAR-GRIP

DT##/2 MAHD#-#-XL-JHP

Intermediate Holder with DT
Adaptation for MODULAR-GRIP
Adapters on SCHUTTE Machine Tools

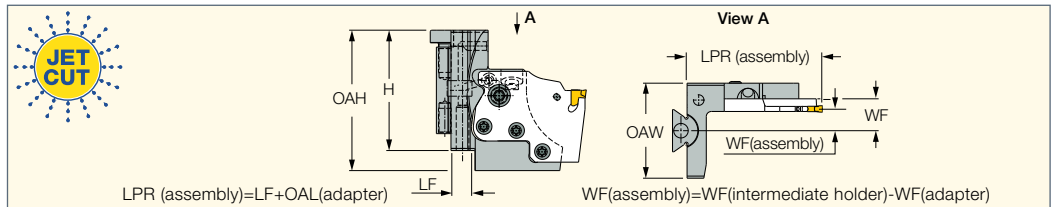

Designation	H	OAW	LF	WF	OAH
DT20/2 MAHDL-L-XL-JHP	57.0	45.00	9.10	4.50	66.50
DT20/2 MAHDN-L-XL-JHP	57.0	45.00	9.10	6.50	66.50
DT30/2 MAHDR-L-XL-JHP	57.0	55.00	9.10	20.10	65.85
DT30/2 MAHDR-R-XL-JHP	57.0	55.00	9.10	21.50	65.85

• All trademarks and logos are the property of their respective companies

For tools, see pages: DGPAD-JHP (480) • PCADRS/LS-JHP (317) • PCLNR/L-PAD-JHP (25) • PDJNR/L-PAD-JHP (38)

• SCLCR/L-PAD-JHP (71) • SDJCR/L-PAD-JHP (78) • SVJCR/L-PAD-JHP (88) • TAGPAD-JHP (500)

Spare Parts

Designation							
DT##/2 MAHD#-#-XL-JHP	SUPPORT MG-XL-5113377	T-20/5	SR M5-04451	HW 5.0	SR M5X5 DIN913 TL360	OR 5X1N	HW 2.5



MODULAR-GRIP

DT30/2 ##L70WN

Intermediate Holder with DT30
Adaptation for Boring Bars on
SCHUTTE Machine Tools

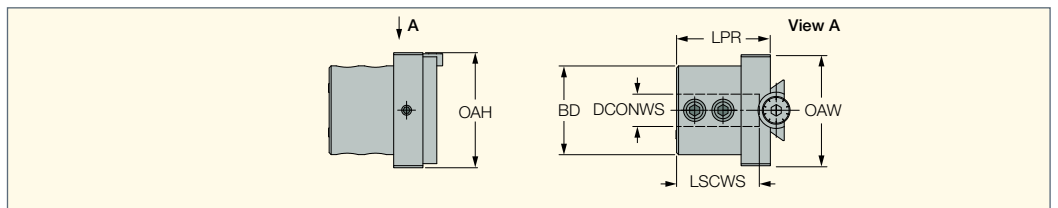

Designation	OAH	OAW	DCONWS	BD	LPR	LSCWS
DT30/2 16L70WN	57.00	55.00	16.00	44.00	46.50	41.00
DT30/2 20L70WN	57.00	55.00	20.00	48.00	46.50	41.00

• All trademarks and logos are the property of their respective companies



MODULAR-GRIP

DT30/2 ADR-##-20-55

Intermediate Holder with DT30
Adaptation for Boring Bars on
SCHUTTE Machine Tools

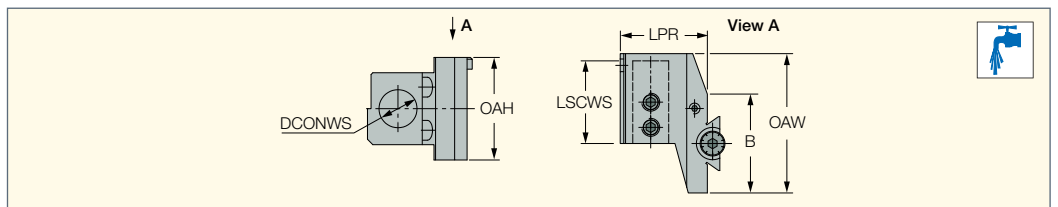

Designation	OAH	OAW	DCONWS	LPR	B	LSCWS
DT30/2 ADR-20-55	57.00	65.00	20.00	45.50	55.0	41.00
DT30/2 ADR-Z0-20-55	57.00	77.50	20.00	48.50	55.0	46.00

• All trademarks and logos are the property of their respective companies

All trademarks and logos are the property of their respective companies

DT30/2 ASH# 16/20-1-35080

Intermediate Holder with
DT30 Adaptation for
Square Shank Tools on
SCHUTTE Machine Tools

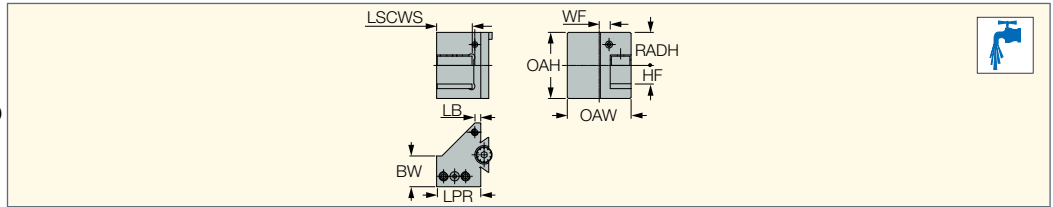

Designation	HF	WF	LPR	OAH	LB	RADH	BW	OAW	LSCWS
DT30/2 ASH/L 16/20-1-35080	16.0	9.50	38.00	57.00	5.00	28.50	26.50	55.00	32.00

• All trademarks and logos are the property of their respective companies

MS-ES#####-GWS-MG-JHP

Toolholders for Goltenbodt
GWS Systems with
Internal Coolant Supply for
MODULAR-GRIP Adapters

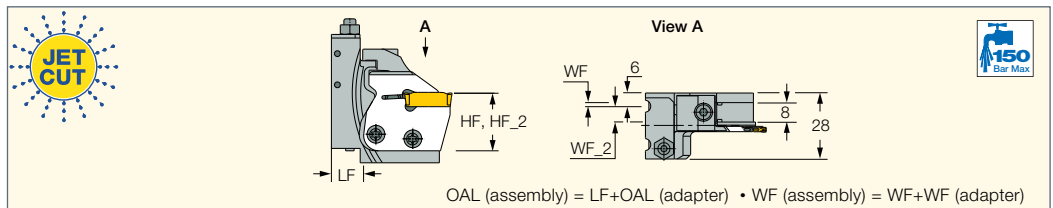

OAL (assembly) = LF+OAL (adapter) • WF (assembly) = WF+WF (adapter)

Designation	LF	WF	WF_2	HF ⁽¹⁾	HF_2 ⁽²⁾
MS-ES02012-GWS-MG-JHP	14.00	2.00	6.00	24.0	27.0
MS-ES02013-GWS-MG-JHP	22.00	2.00	6.00	24.0	27.0
MS-ES09003-GWS-MG-JHP	14.00	2.00	6.00	24.0	30.0
MS-ES41008-GWS-MG-JHP	22.00	2.00	6.00	24.0	27.0
MS-ES41009-GWS-MG-JHP	22.00	2.00	6.00	24.0	27.0

• For user guide, see pages 852-858 • All trademarks and logos are the property of their respective companies

⁽¹⁾ Center height adjustment for GWS43

⁽²⁾ Center height adjustment for GWS60

For tools, see pages: PCLNR/L-PAD-JHP (25) • PDJNR/L-PAD-JHP (38) • SCLCR/L-PAD-JHP (71) • SDJCR/L-PAD-JHP (78)

• SVJCR/L-PAD-JHP (88) • DGPAD-JHP (538) • TAGPAD-JHP (562) • CGPAD-JHP (309) • HGPAD-JHP (291) • PCADR/L-JHP (353) • TGPAD-JHP (298)

• PCADRS/LS-JHP (354)

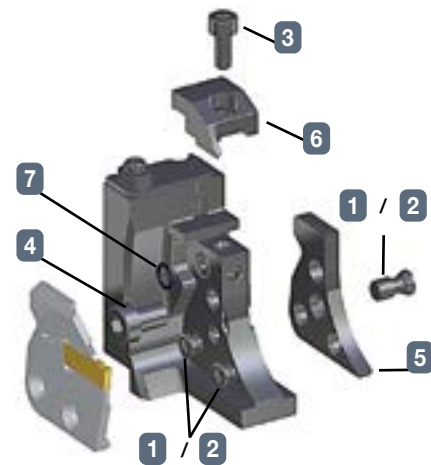
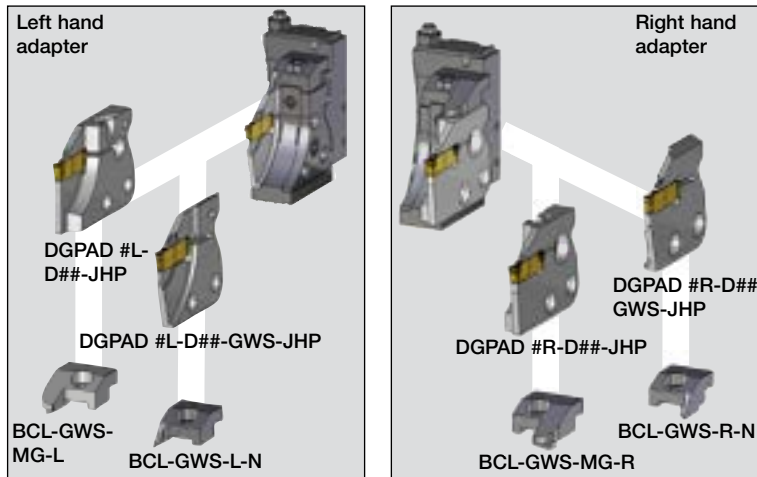
Wedge Selection Guide (must be ordered separately)

Spare Parts MS-ES#####-GWS-MG-JHP

No.	Designation	MS-ES02012-GWS-MG-JHP	MS-ES02013-GWS-MG-JHP	MS-ES09003-GWS-MG-JHP	MS-ES41008-GWS-MG-JHP	MS-ES41009-GWS-MG-JHP
1	Screw	SR 16-212-L9,5	SR 16-212-L9,5	SR 16-212-L9,5	SR 16-212-L9,5	SR 16-212-L9,5
2	Key	T-20/5	T-20/5	T-20/5	T-20/5	T-20/5
3	Screw	DIN912-M4X10-12,9	DIN912-M4X10-12,9	DIN912-M4X10-12,9	DIN912-M4X10-12,9	DIN912-M4X10-12,9
4	Screw	SR M6X6-DIN6912-10,9	SR M6X6-DIN6912-10,9	SR M6X6-DIN6912-10,9	SR M6X6-DIN6912-10,9	SR M6X6-DIN6912-10,9
5	Dummy	GWS Dummy	GWS Dummy	GWS Dummy	GWS Dummy	GWS Dummy
6	Wedges*					
7	O-Ring	OR 5X1N	OR 5X1N	OR 5X1N	OR 5X1N	OR 5X1N

* Should be ordered separately



All trademarks and logos are the property of their respective companies

ISCAR Modular System for Turning Lathes

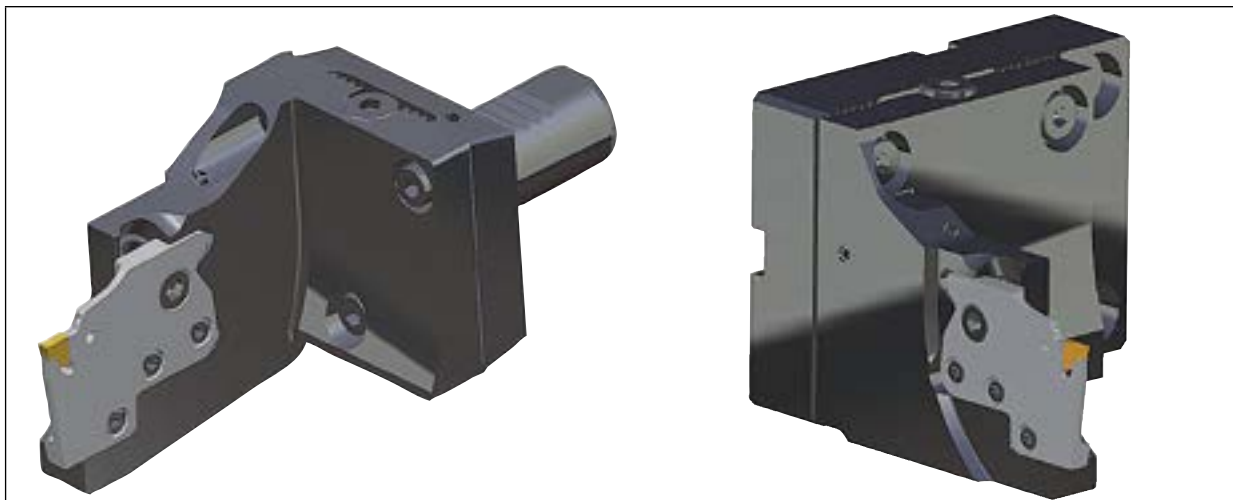
Toolholder System with Machine-Specific Adaptations for Turning Lathes

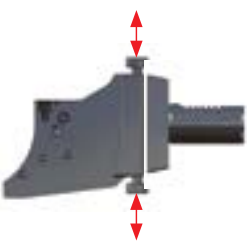
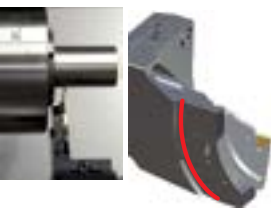

Features and Benefits of Machine-Specific Toolholder Systems

	Flexible Vario System	Adjustable Center Height	Optimized Holder Design	No Coolant Tubes / Hoses
Features:				
Benefits:	<ul style="list-style-type: none"> • Uniform intermediate holders and adapters on different machine adaptations • Low tool stock • Modular design 	<ul style="list-style-type: none"> • Optimal tool life due to adjustable center height • Reliable tool life • Turret malpositions can be balanced 	<ul style="list-style-type: none"> • Long tool life due to reduced bar overhang, less vibrations • Slim design • Low risk of collision • Suitable for any machine-specific clamping interface 	<ul style="list-style-type: none"> • Chips do not accumulate in the work space (no coolant tube / hose required) • Reliable coolant supply due to fixed flow orientation (no adjustable coolant nozzle)

All trademarks and logos are the property of their respective companies

ISCAR Modular System for Turning Lathes

System Overview

VDI



CAMFIX



DMG MORI



Mazak



Nakamura-Tome



OKUMA



VDI-P



HSK



BMT



Miyano



Biglia / EUROTECH



TSUGAMI



TRAUB TNL18 / 32



TRAUB TNK 42 / 65



TRAUB TNK 36 / TNL26



Tang-Grip-XL



Tang-Grip



Do-Grip



Cut-Grip



Heli-Grip



INDEX ABC



All trademarks and logos are the property of their respective companies

ISCAR Modular System for Turning Lathes

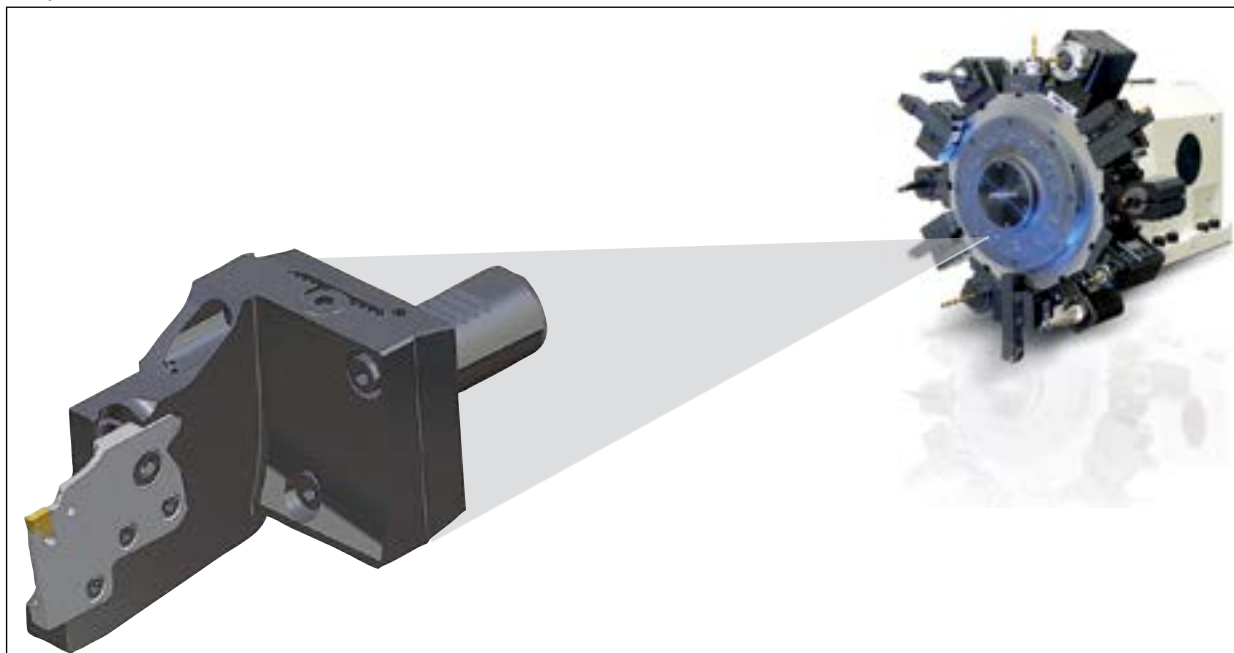
Toolholder System for Star Turrets with VDI and MODULAR-GRIP-XL Adaptations and Directed Internal Coolant

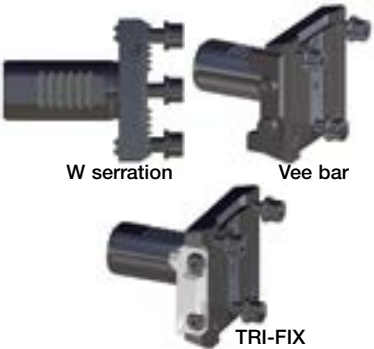
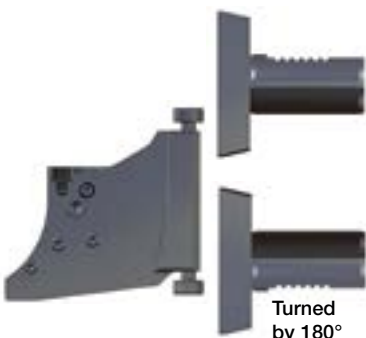

Features and Benefits of Machine-Specific Toolholder Systems

	Adaptation Sizes	Alignment Systems	VDI shank can be rotated by 180°
Features:	 <p>VDI20 VDI25</p>  <p>VDI30 VDI40</p>	 <p>W serration Vee bar</p> <p>TRI-FIX</p>	 <p>Turned by 180°</p>
Benefits:	<ul style="list-style-type: none"> • DIN69880 (ISO 10889-1) • VDI20 • VDI25 • VDI30 • VDI40 	<ul style="list-style-type: none"> • Extremely stable, torsion resistant and high-end precision 	<ul style="list-style-type: none"> • The serration can be mounted at the top or bottom • Double-serration is not necessary

All trademarks and logos are the property of their respective companies

ISCAR Modular System for Turning Lathes

Toolholder System for Disc-Type Turrets with VDI and MODULAR-GRIP-XL Adaptations and Directed Internal Coolant

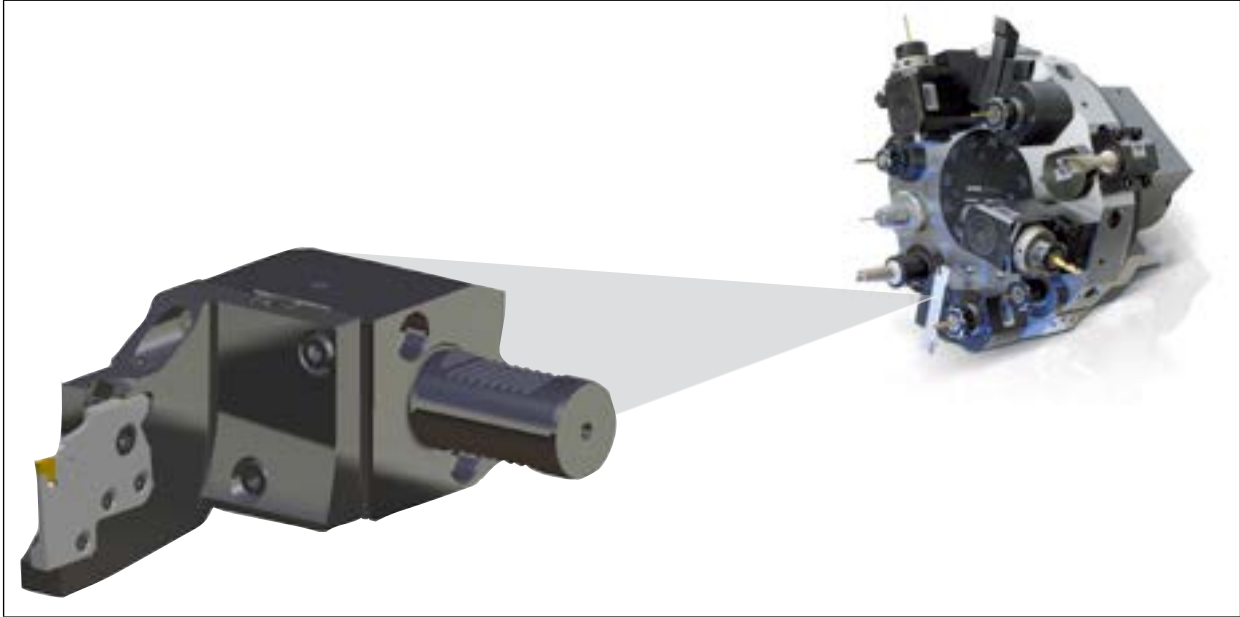

Features and Benefits of Machine-Specific Toolholder Systems

	Adaptation Sizes	Parting Next to Main Spindle or Sub-Spindle	Reliable Processes
Features:	<p>VDI30-P VDI40-P</p>		
Benefits:	<ul style="list-style-type: none"> • DIN69880 (ISO 10889-1) • VDI30-P • VDI40-P 	<ul style="list-style-type: none"> • Low risk of collision due to optimized tool design • Parting next to main spindle or sub-spindle depending on component length 	<ul style="list-style-type: none"> • Chips do not accumulate in the work space (no coolant tube / hose required) • Reliable coolant supply due to fixed flow orientation (no adjustable coolant nozzle)

All trademarks and logos are the property of their respective companies

ISCAR Modular System for Turning Lathes

Toolholder System for DOOSAN / HAAS Machines with BMT and MODULAR-GRIP-XL Adaptations and Directed Internal Coolant

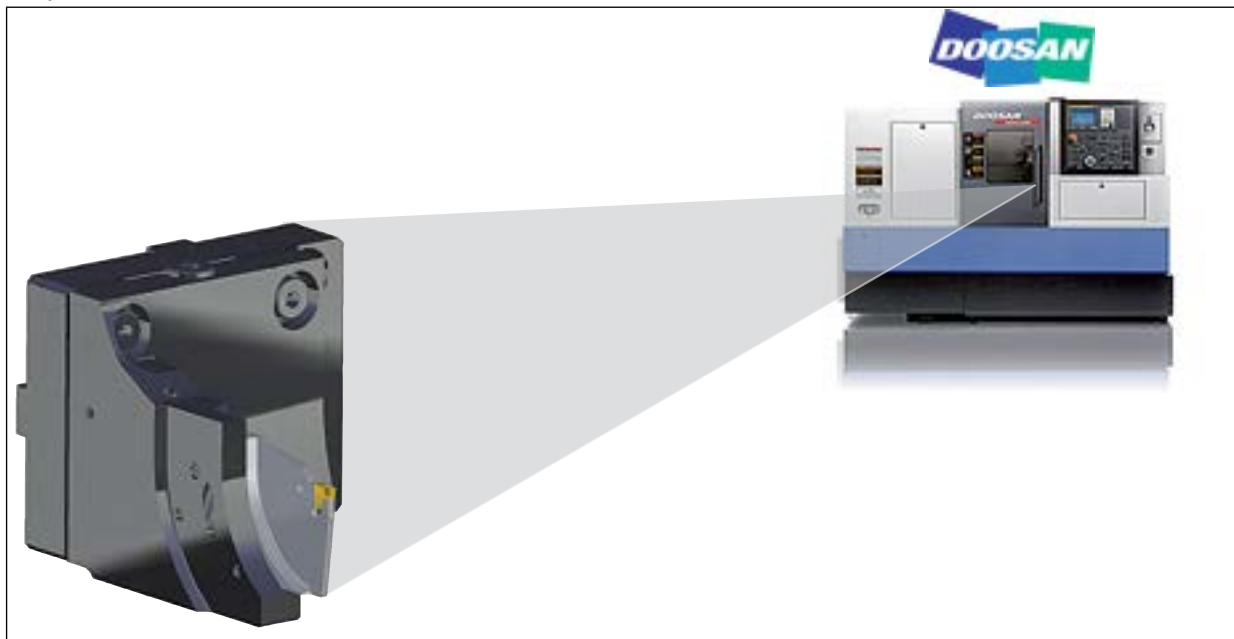

Features and Benefits of Machine-Specific Toolholder Systems

	Adaptation Sizes	Holder Turning Ability 180°	Reliable Processes
Features:	<p>BMT45 BMT55 BMT65</p>		
Benefits:	<ul style="list-style-type: none"> • BMT (Base Mounted Turret) • BMT45 • BMT55 • BMT65 	<ul style="list-style-type: none"> • Tool can be mounted on the left or right of the turret • Extremely flexible due to few elements 	<ul style="list-style-type: none"> • Chips do not accumulate in the work space (no coolant tube / hose required) • Reliable coolant supply due to fixed flow orientation (no adjustable coolant nozzle)

All trademarks and logos are the property of their respective companies

ISCAR Modular System for Turning Lathes

Toolholder System for **DMG MORI** Machines with MODULAR-GRIP-XL Adaptation and Directed Internal Coolant

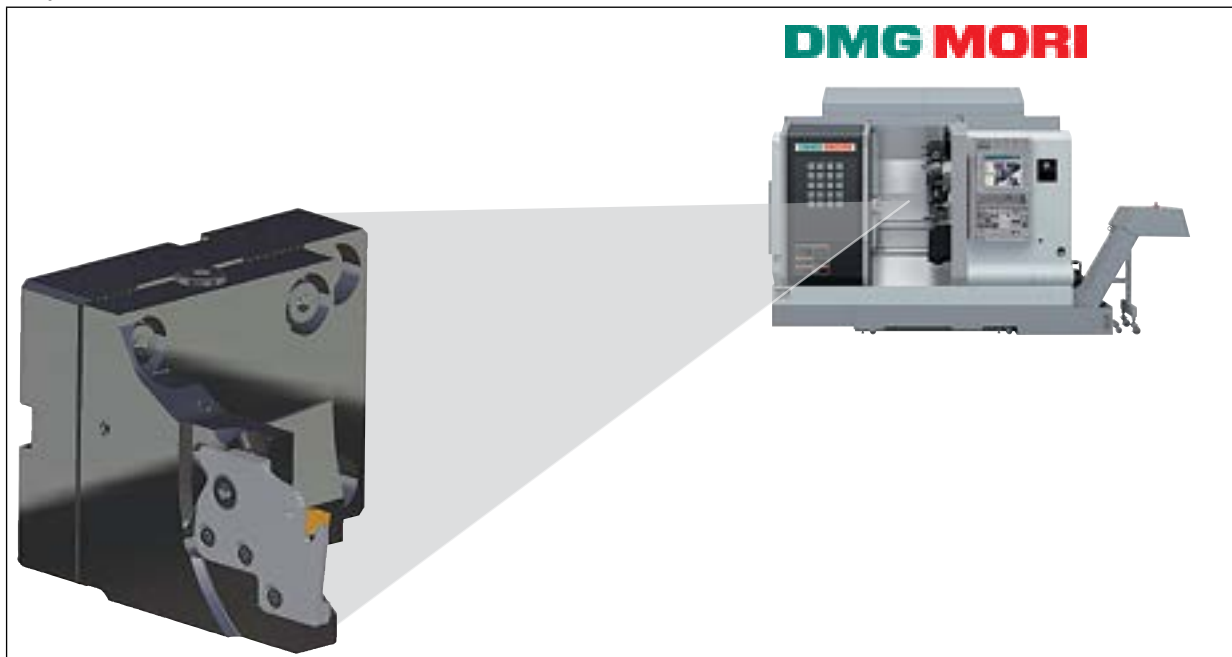

Features and Benefits of Machine-Specific Toolholder Systems

	Adaptation Sizes	Two Pockets for Intermediate Holders	Reliable Processes
Features:	<p>MORI40 MORI60</p> <p>ø 40 ø 60</p>	<p>(For MORI60)</p> <p>1. pocket next to (main) spindle 2. pocket next to (sub-) spindle</p>	
Benefits:	<ul style="list-style-type: none"> • DMG MORI turrets for NZ machines • MORI40 • For NL machines • MORI60 	<ul style="list-style-type: none"> • Intermediate holder can be mounted on the left or right side of the turret • Modular flexibility due to few elements 	<ul style="list-style-type: none"> • Chips do not accumulate in the work space (no coolant tube/hose required) • Reliable coolant supply due to fixed flow orientation (no adjustable coolant nozzle)

All trademarks and logos are the property of their respective companies

ISCAR Modular System for Turning Lathes

Toolholder System for MAZAK Machines with MODULAR-GRIP-XL Adaptation and Directed Internal Coolant

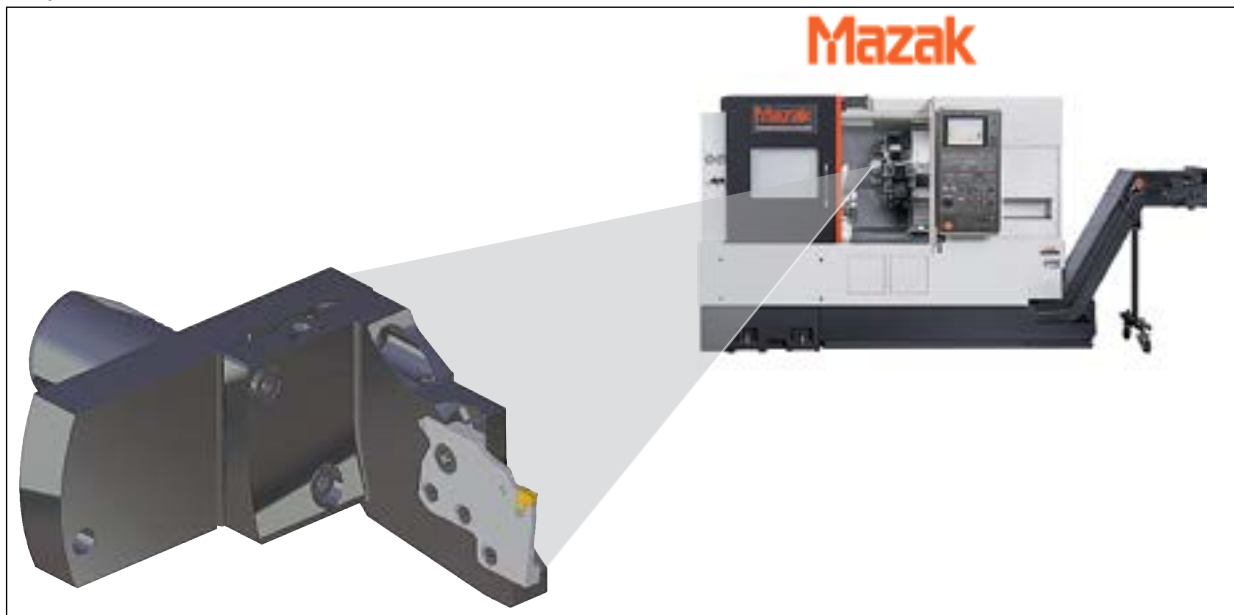

Features and Benefits of Machine-Specific Toolholder Systems

	Adaptation Sizes	Adaptation Features	Reliable Processes
Features:	<p>MA4016E MA4020E MA5020E MA4016T MA4020T</p>	<p>MA####E MA####T</p>	
Benefits:	<ul style="list-style-type: none"> • For Mazak Quick Turn, Hyper Quardrex and Multiplex machines • MA4016E • MA4020E • MA5020E • MA4016T • MA4020T 	<ul style="list-style-type: none"> • Suitable for any common Mazak adaptations 	<ul style="list-style-type: none"> • Chips do not accumulate in the work space (no coolant tube / hose required) • Reliable coolant supply due to fixed flow orientation (no adjustable coolant nozzle)

All trademarks and logos are the property of their respective companies

ISCAR Modular System for Turning Lathes

Toolholder System for Machines with **CAMFIX** MODULAR-GRIP-XL Adaptations and Directed Internal Coolant

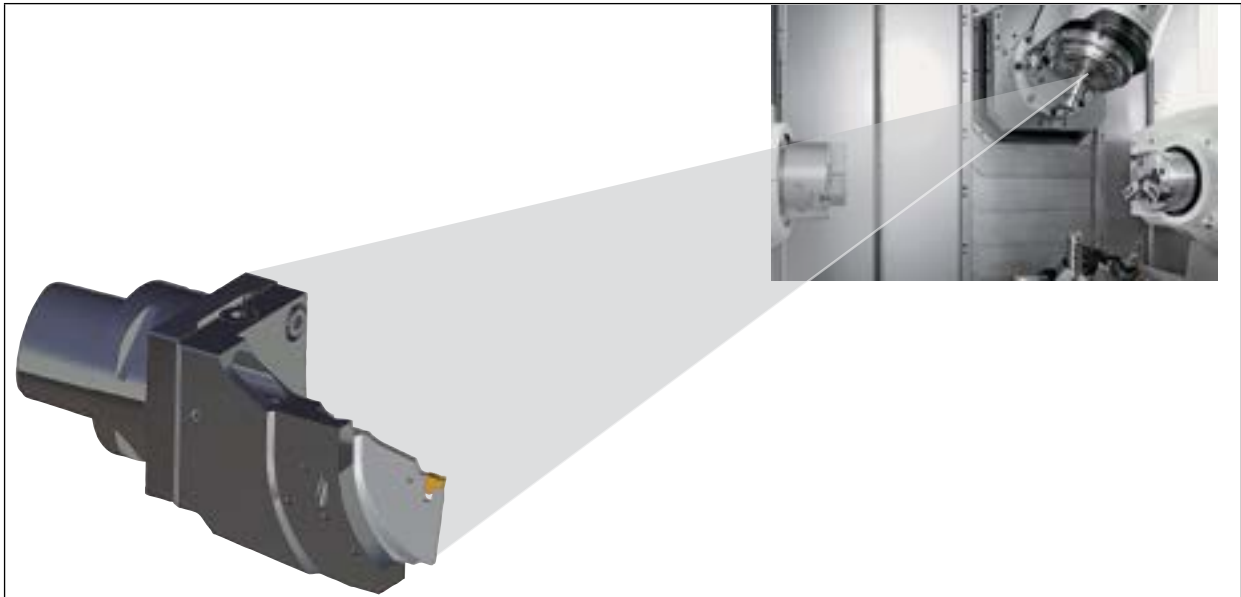

Features and Benefits of Machine-Specific Toolholder Systems

	Adaptation Sizes	Parting Next to Main Spindle and Sub-Spindle	Reliable Processes
Features:			
Benefits:	<ul style="list-style-type: none"> • For CAMFIX turrets and for turn-mill centers with a CAMFIX ISO26623-1 milling spindle • C4 • C5 • C6 	<ul style="list-style-type: none"> • Low risk of collision due to optimized tool design • Parting next to main spindle or sub-spindle depending on the component length 	<ul style="list-style-type: none"> • Chips do not accumulate in the work space (no coolant tube / hose required) • Reliable coolant supply due to fixed flow orientation (no adjustable coolant nozzle)

All trademarks and logos are the property of their respective companies

ISCAR Modular System for Turning Lathes

Toolholder Systems for Turn-Mill Centers with HSK Shank and MODULAR-GRIP-XL Adaptation and Directed Internal Coolant

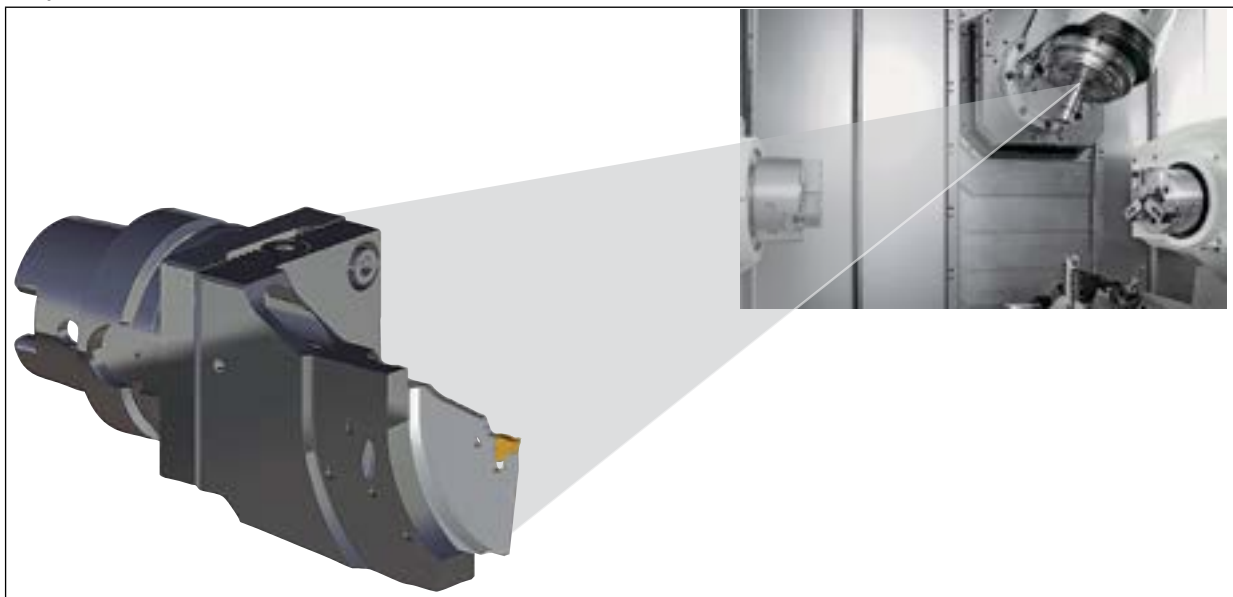

Features and Benefits of Machine-Specific Toolholder Systems

	Adaptation Sizes	Relief for Automatic Tool Changers	Reliable Processes
Features:	<p>HSK T 40</p> <p>HSK T 63</p>	<p>Relief for tool exchanger</p>	
Benefits:	<ul style="list-style-type: none"> • For HSK T turrets and for turn-mill centers with HSK T milling spindles • HSK T 40 • HSK T 63 	<ul style="list-style-type: none"> • Tools can be used on machines with an automatic tool exchanger 	<ul style="list-style-type: none"> • Chips do not accumulate in the work space (no coolant tube / hose required) • Reliable coolant supply due to fixed flow orientation (no flexible coolant nozzle)

All trademarks and logos are the property of their respective companies





ISCAR Modular System for Turning Lathes

Toolholder Systems for **Biglia / EUROTECH, MIYANO** and **NAKAMURA TOME** with MODULAR-GRIP-XL Adaptation and Directed internal Coolant

Toolholder Systems for Biglia / EUROTECH, Miyano and Nakamura Tome

 		 
		
<ul style="list-style-type: none"> • Holder for Biglia / EUROTECH turrets • BI40 • BI55 	<ul style="list-style-type: none"> • Holder for MIYANO turrets • MI40 • MI45 • MI55 	<ul style="list-style-type: none"> • Holder for NAKAMURA-TOME turrets • NT55 • NT65

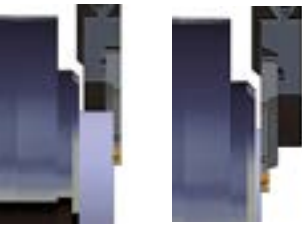
Features and Benefits of Machine-Specific Toolholder Systems

	Optimized Holder Design	Parting Next to Main Spindle and Sub-Spindle	Reliable Processes
Features:	 		
Benefits:	<ul style="list-style-type: none"> • Long tool life due to small bar overhang and less vibrations • Slim design • Low risk of collision • Suitable for any machine-specific clamping device 	<ul style="list-style-type: none"> • Low risk of collision due to optimized tool design • Parting next to main spindle or sub-spindle depending on the correspondent length 	<ul style="list-style-type: none"> • Chips do not accumulate in the work space (no coolant tube / hose required) • Reliable coolant supply due to fixed flow orientation (no adjustable coolant nozzle)



All trademarks and logos are the property of their respective companies

ISCAR Modular System for Turning Lathes

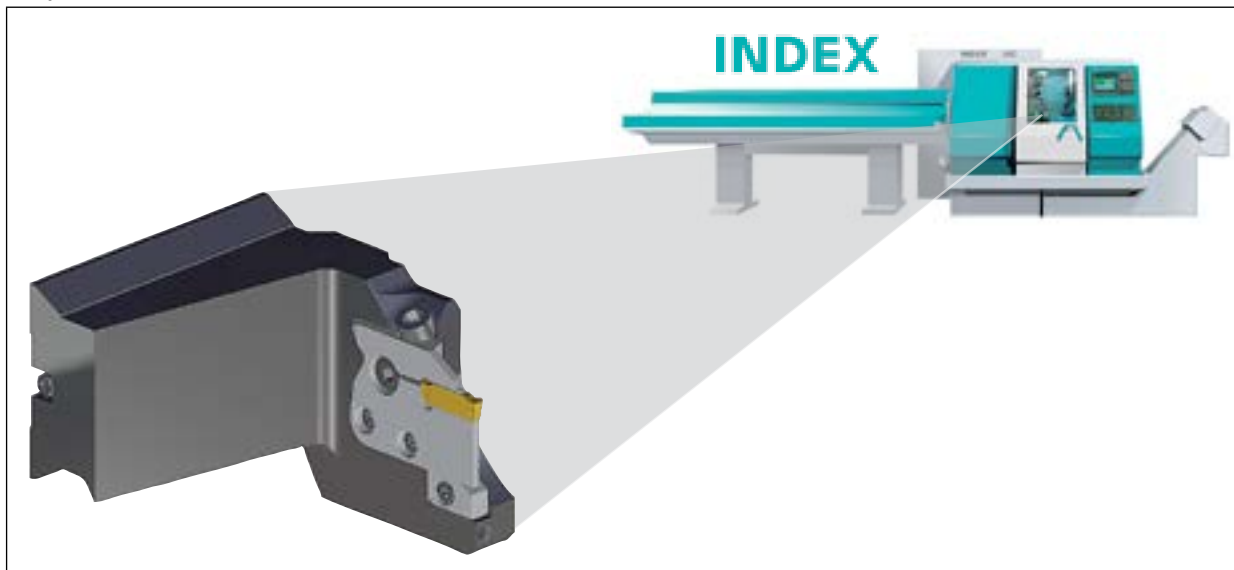
Toolholder System for **INDEX ABC** Machines with **MODULAR-GRIP-XL** Adaptation and Directed Internal Coolant

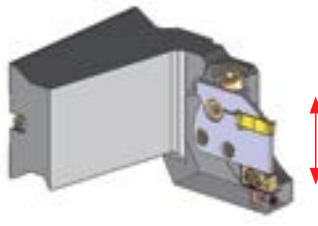

Features and Benefits of Machine-Specific Toolholder Systems

	Adaptation Sizes	Height Adjustment +0.2 mm	Machine Optimized Tool Design
Features:			
Benefits:	<ul style="list-style-type: none"> • For Index ABC machines turret 2 • Prismatic adaptation 	<ul style="list-style-type: none"> • Mismatch of turrets can be adjusted • Extremely long tool life due to exact center height 	<ul style="list-style-type: none"> • Extremely long tool life due to very stable tool design • Reduced vibrations due to reduced bar overhang • Reliable coolant supply due to fixed flow orientation (no adjustable coolant nozzle)

All trademarks and logos are the property of their respective companies

ISCAR Modular System for Turning Lathes

Toolholder System for Integral Shank 45 with MODULAR-GRIP-XL Adaptation and Directed Internal Coolant

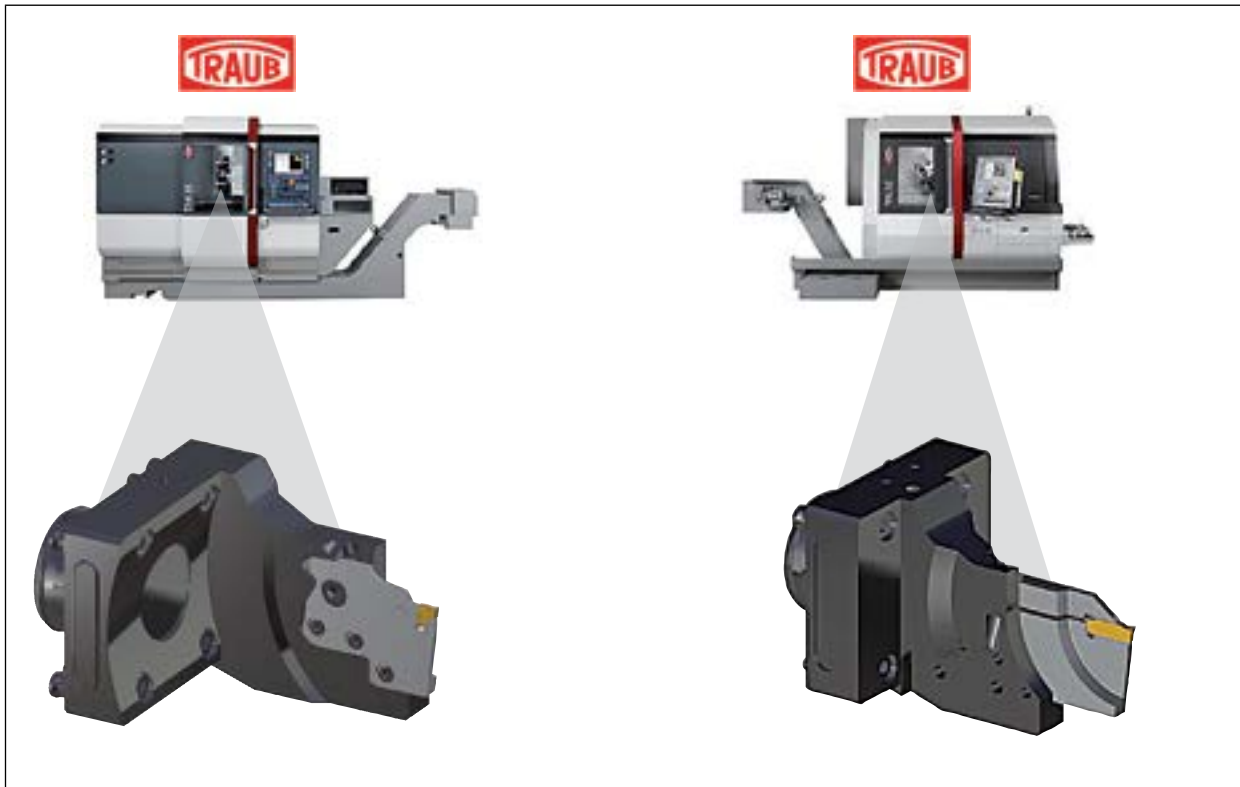

Features and Benefits of Machine-Specific Toolholder Systems

	TNK 36 / TNL 26	TNL 18 / TNL 32	TNK 42 / TNK 65
Features:			
Benefits:	<ul style="list-style-type: none"> • Dovetail connection for Traub TNK36 and TNL26 Machines • Tools are suitable for parting and grooving applications • Suitable for any machine-specific clamping device 	<ul style="list-style-type: none"> • Integral shank 45 for Traub TNL18 and TNL32 • Tools are suitable for parting and grooving applications • Suitable for any grooving systems with directed internal coolant 	<ul style="list-style-type: none"> • Low risk of collision due to machine-specific tool design • Tool is suitable for parting and grooving applications • Suitable for any machine-specific clamping device



All trademarks and logos are the property of their respective companies

Adapters with internal coolant

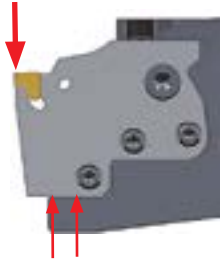
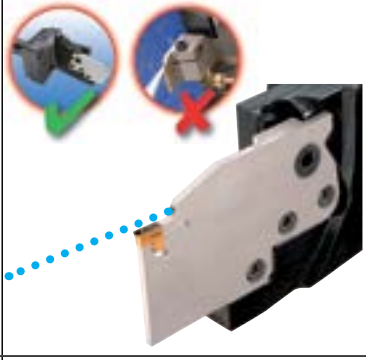
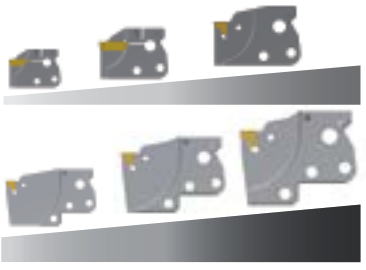
Features and Benefits of Machine-Specific Toolholder Systems

	Extremely Stable	Coolant Directly to the Cutting Zone	Additional External Diameters
Features:			
Benefits:	<ul style="list-style-type: none"> • Very long tool life as the cutting forces are directly transmitted to the intermediate holder • Very rigid due to additional clamping screw in the Modular-Grip-XL adapters pocket • Less vibrations due to rigid tool design 	<ul style="list-style-type: none"> • Reliable tool life due to fixed flow orientation (no adjustable coolant nozzle) • Chips do not accumulate in the work space (no coolant tube / hose required) • Very efficient due to small distance between coolant exit and cutting zone 	<ul style="list-style-type: none"> • Long tool life due to reduced vibrations by reinforced tool body • Suitable for all popular bar diameters









Features and Benefits of Machine-Specific Toolholder Systems

	MODULAR-GRIP/ MODULAR-GRIP-XL	Vario System	Coolant Connection from the Turret into the Cutting Zone
Features:		 <p>TAGPAD-JHP TAGPAD-XL-JHP HGPAD-JHP DGPAD-JHP CGPAD-JHP</p>	
Benefits:	<ul style="list-style-type: none"> • Very flexible due to compatibility with existing adapter systems • Modular-Grip and Modular-Grip-XL adapters can be mounted • High rigidity using Modular-Grip adapters by additional support 	<ul style="list-style-type: none"> • Very flexible • Suitable for any JHP grooving systems • Direct cooling for grooving and turn-groove operations • A variety of options with a single holder 	<ul style="list-style-type: none"> • Fast setup, less downtime • Chips do not accumulate in the work space • Easy handling, low risk of error

All trademarks and logos are the property of their respective companies

ISCAR Modular System for Turning Lathes

Tool Design Overview

L-R	<p>#### MAHDL-R-XL-JHP</p> 	 <p>Upside down</p>
R-L	<p>#### MAHDR-L-XL-JHP</p>  <p>Upside down</p>	
R-R	<p>#### MAHDR-R-XL-JHP</p>  <p>Upside down</p>	
L-L	<p>#### MAHDL-L-XL-JHP</p> 	 <p>Upside down</p>

All trademarks and logos are the property of their respective companies

ISCAR Modular System for Turning Lathes

Tool Selection

Example:



1 Defined Machine Adaptations

Type	VDI	VDI with W-serration	VDI with Vee-bar	VDI for disc type turret	BMT	DMG MORI	MAZAK	CAMFIX	HSK T	Biglia / EUROTECH	Miyano	Nakamura-Tome
Size	VDI20	VDI25W	VDI25V	VDI30-P	BMT45	MORI40	MA4016E	C4	HSK T 40	BI40	MI40	NT45
	VDI25	VDI30W	VDI30V	VDI40-P	BMT55	MORI60	MA4020E	C5	HSK T 63	BI55	MI45	NT55
	VDI30	VDI40W	VDI40V		BMT65		MA5020E	C6			MI55	NT65
	VDI40						MA4016T MA4020T					

For details on adaptation please see technical information (starting at page 877).

2 Defined Turning Direction at the Main Spindle

View through the spindle into the work space

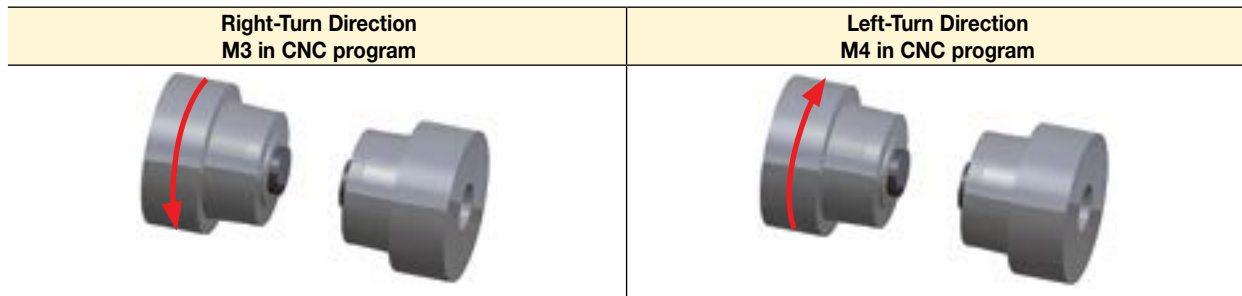

3 Position of the Adapter Pocket

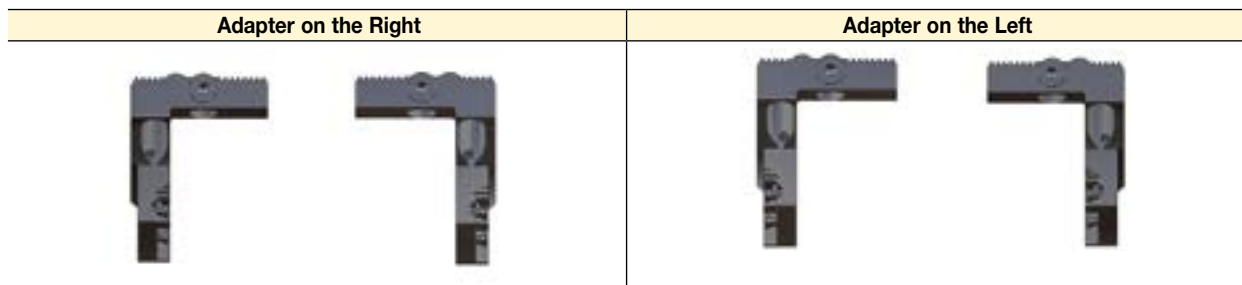

All trademarks and logos are the property of their respective companies

VDI MODULAR-GRIP

VDI#### V##-JHP

Toolholders for Star Turrets with VDI Adaptation and Internal Coolant Supply for MODULAR-GRIP-XL Adapters

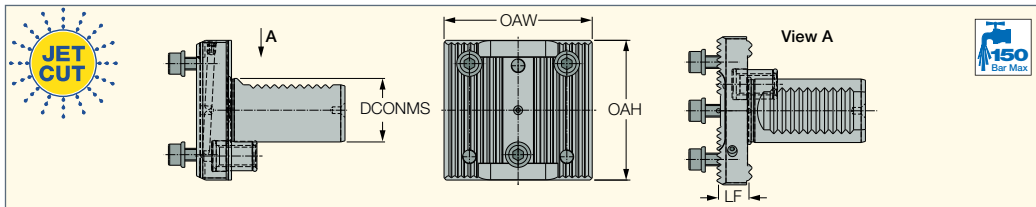

Designation	DCONMS	OAW	OAH	LF	Align.
VDI20 V60-JHP	20.00	60.00	56.00	13.50	-
VDI25 V60-JHP	25.00	60.00	61.20	12.75	-
VDI25TF V60-JHP	25.00	60.00	61.20	12.75	TriFix
VDI25V V60-JHP	25.00	60.00	61.20	12.75	V-Bar
VDI25W V60-JHP	25.00	60.00	61.20	13.40	W-toothing
VDI30 V60-JHP	30.00	70.00	66.00	13.75	-
VDI30TF V60-JHP	30.00	70.00	66.00	13.75	TriFix
VDI30V V60-JHP	30.00	70.00	66.00	13.75	V-Bar
VDI30W V60-JHP	30.00	70.00	66.00	14.40	W-toothing
VDI40 V85-JHP	40.00	85.00	82.00	15.75	-
VDI40TF V85-JHP	40.00	85.00	82.00	15.75	TriFix
VDI40V V85-JHP	40.00	85.00	82.00	15.75	V-Bar
VDI40W V85-JHP	40.00	85.00	82.00	16.35	W-toothing

• For user guide, see pages 862-876

VDI MODULAR-GRIP

VDI##-P V60-JHP

Toolholders for Disc-Type Turrets with VDI Adaptation and Internal Coolant Supply for MODULAR-GRIP-XL Adapters

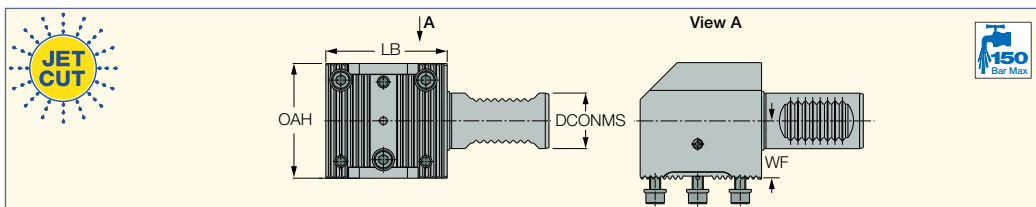

Designation	DCONMS	LB	OAH	WF	WB
VDI30-P V60-JHP	30.00	65.60	62.00	30.75	63.00
VDI40-P V60-JHP	40.00	65.60	80.00	34.75	70.50

• For user guide, see pages 862-876



MODULAR-GRIP

BMT## V85-JHP

Toolholders for BMT Turrets with Internal Coolant Supply for MODULAR-GRIP-XL Adapters

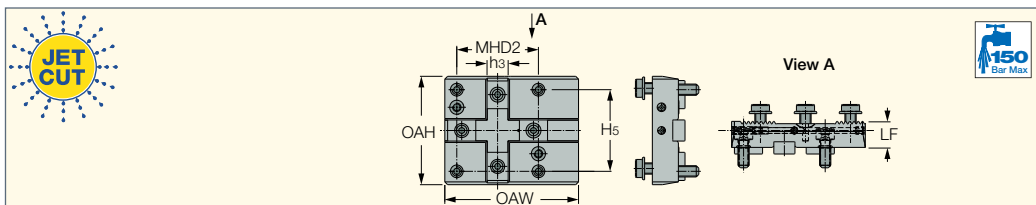

Designation	OAW	OAH	LF	H5	MHD2	h3
BMT45 V85-JHP ⁽¹⁾	95.00	77.00	17.45	58.00	58.0	15.0
BMT55 V85-JHP	103.50	84.00	20.75	64.00	64.0	15.0
BMT65 V85-JHP	114.50	98.00	25.75	73.00	70.0	18.0
BMT75 V85-JHP	120.00	112.00	29.25	90.00	90.0	25.0

• All trademarks and logos are the property of their respective companies

• For user guide, see pages 862-876

⁽¹⁾ Suitable for Hyundai-Wia SE2200 Turning Centers

DMG MORI
MODULAR-GRIP

MORI## V85-JHP
Turrets with Internal Coolant
Supply for MODULAR-GRIP-XL Adapters

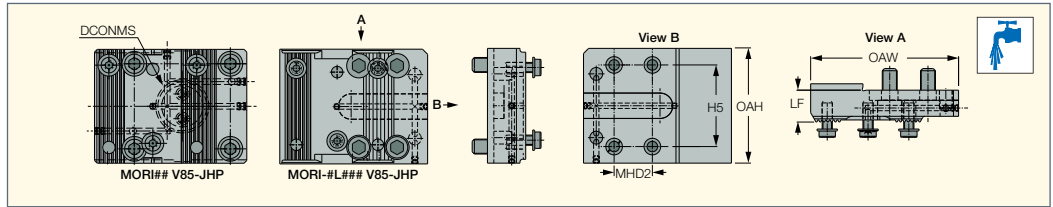

Designation	OAW	OAH	LF	H5	MHD2	DCONMS
MORI40 V85-JHP	111.00	83.00	25.75	62.00	70.0	39.90
MORI-DL151 V85-JHP	116.00	90.00	24.25	64.00	30.0	-
MORI-SL200 V85-JHP	126.00	100.00	24.25	76.00	35.0	-
MORI60 V85-JHP	172.00	109.30	29.25	84.00	94.0	59.90

• All trademarks and logos are the property of their respective companies • For user guide, see pages 862-876

Mazak
MODULAR-GRIP

MA#### V##-JHP
Toolholders for Mazak Turrets
with Internal Coolant Supply for
MODULAR-GRIP-XL Adapters

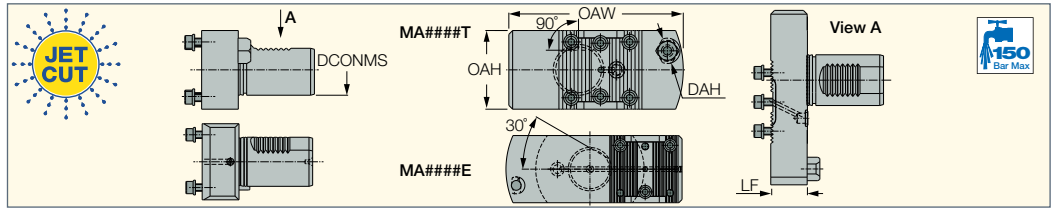

Designation	DCONMS	DAH	OAW	OAH	LF
MA4016T V60-JHP	40.00	16.00	132.50	62.00	28.15
MA4020T V60-JHP	40.00	20.00	137.50	62.00	28.15
MA4016E V60-JHP	40.00	16.00	162.50	62.00	29.25
MA4020E V60-JHP	40.00	20.00	170.00	62.00	29.25
MA5020E V85-JHP	50.00	20.00	168.50	100.00	45.75

• All trademarks and logos are the property of their respective companies • For user guide, see pages 862-876

MODULAR-GRIP
CAMFIX

C#-V60-JHP
Toolholders for CAMFIX
Adaptations with Internal
Coolant Supply for MODULAR-GRIP-XL Adapters

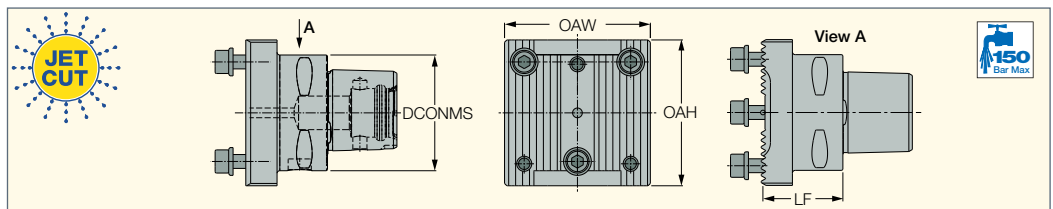

Designation	DCONMS	OAW	OAH	LF
C4 V60-JHP	40.00	63.00	63.00	34.55
C5 V60-JHP	50.00	63.00	63.00	34.55
C6 V60-JHP	63.00	63.00	63.00	36.55

• For user guide, see pages 862-876

MODULAR-GRIP
HSK

HSK T ## V60-JHP
Toolholders for HSK-T
Adaptations with Internal
Coolant Supply for MODULAR-GRIP-XL Adapters

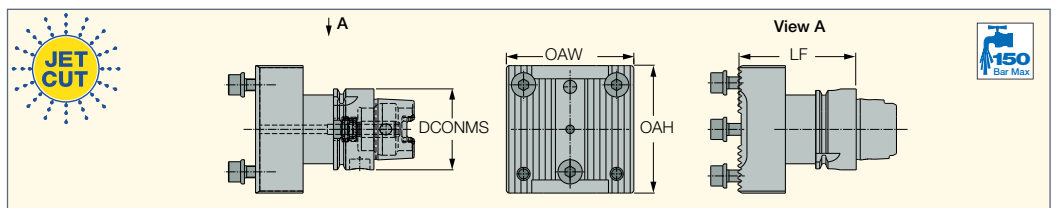

Designation	DCONMS	OAW	OAH	LF
HSK T 40 V60-JHP	40.00	63.00	63.00	57.75
HSK T 63 V60-JHP	63.00	63.00	63.00	57.75

• For user guide, see pages 862-876

All trademarks and logos are the property of their respective companies

MODULAR-GRIP

BI## V##-JHP

Toolholders for Biglia/
EUROTECH Adaptation with
Internal Coolant Supply for
MODULAR-GRIP-XL Adapters

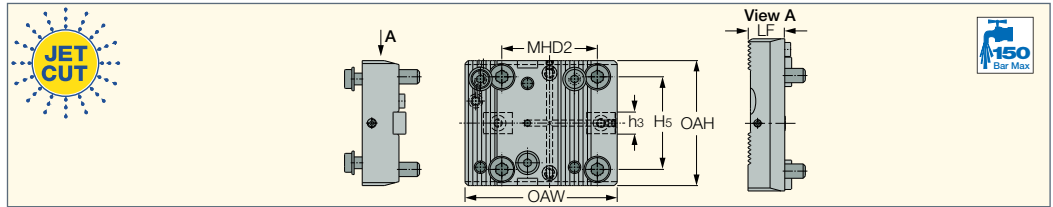

Designation	OAW	OAH	LF	H5	MHD2	h3
BI40 V60-JHP	83.00	70.00	20.75	50.00	50.0	12.0
BI55 V85-JHP	103.50	85.00	24.25	63.00	65.0	15.0

• All trademarks and logos are the property of their respective companies • For user guide, see pages 862-876

MODULAR-GRIP

MI## V60-JHP

Toolholders for Miyano
Adaptation with Directed
Internal Coolant for
MODULAR-GRIP-XL Adapters

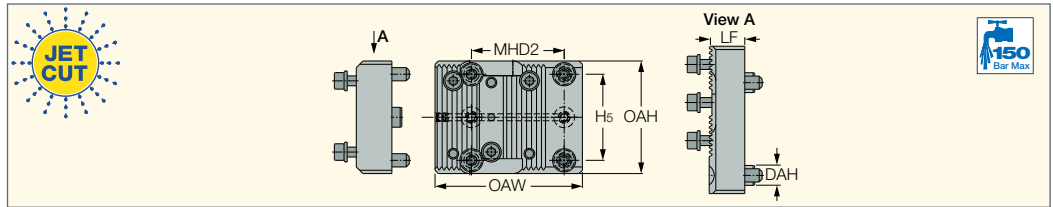

Designation	OAW	OAH	LF	H5	MHD2	DAH
MI40 V60-JHP	89.00	68.00	20.75	52.00	56.0	12.00
MI45 V60-JHP	102.00	72.00	13.95	56.00	68.0	12.00
MI55 V60-JHP	104.00	91.00	15.25	75.00	60.0	12.00

• All trademarks and logos are the property of their respective companies • For user guide, see pages 862-876

MODULAR-GRIP

NT## V60-JHP

Toolholders for Nakamura-
Tome Adaptation with
Internal Coolant Supply for
MODULAR-GRIP-XL Adapters

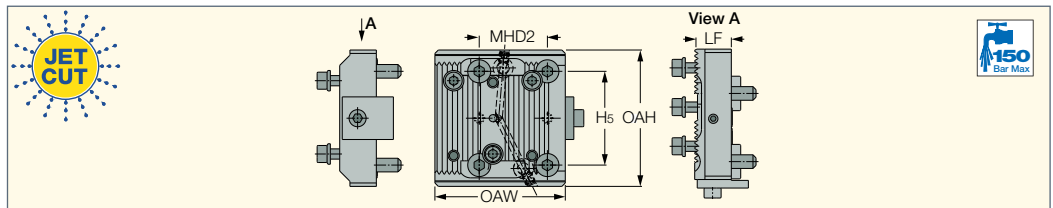

Designation	OAW	OAH	LF	H5	MHD2
NT45 V60-JHP	76.50	80.00	20.75	55.00	40.0
NT55 V60-JHP (1)	87.50	86.00	20.75	60.00	50.0
NT65 V60-JHP	99.50	100.00	20.75	71.00	69.0

• All trademarks and logos are the property of their respective companies • For user guide, see pages 862-876

(1) Suitable for CMZ machines

MODULAR-GRIP

OKUMA # V60-JHP

Toolholders for OKUMA
Adaptation with Internal
Coolant Supply for
MODULAR-GRIP-XL Adapters

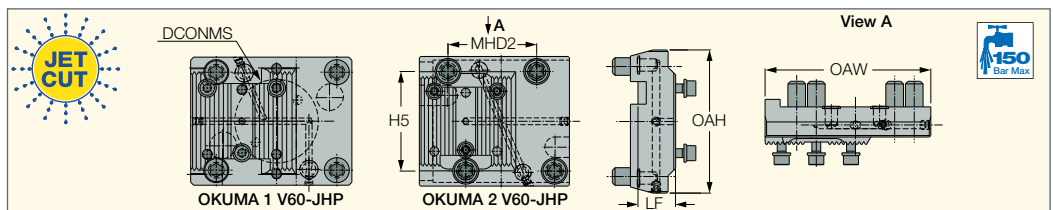

Designation	OAW	OAH	LF	H5	MHD2	DCONMS
OKUMA 1 V60-JHP	107.00	85.00	19.25	65.00	80.0	55.40
OKUMA 2 V60-JHP	110.00 (1)	95.00	24.25	73.00	65.0	-

• All trademarks and logos are the property of their respective companies

(1) also available in 100.00 mm

MODULAR-GRIP

TSU-M08 V60-JHP

Base Holders for TSUGAMI
Adaptation with Internal Coolant
for MODULAR-GRIP-XL Adapters

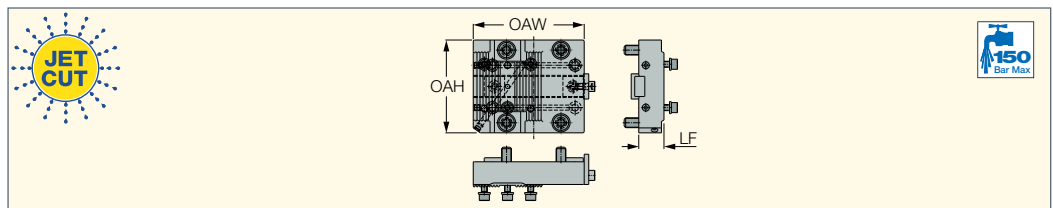

Designation	OAW	OAH	LF
TSU-M08-SY V60-JHP	110.00	92.00	25.00

• All trademarks and logos are the property of their respective companies • For user guide, see pages 862-876

All trademarks and logos are the property of their respective companies

MODULAR-GRIP

V## MAHD#-#-XL-##-JHP
Intermediate Holders for ISCAR
Modular System Holders with
Directed Internal Coolant for
MODULAR-GRIP-XL Adapters

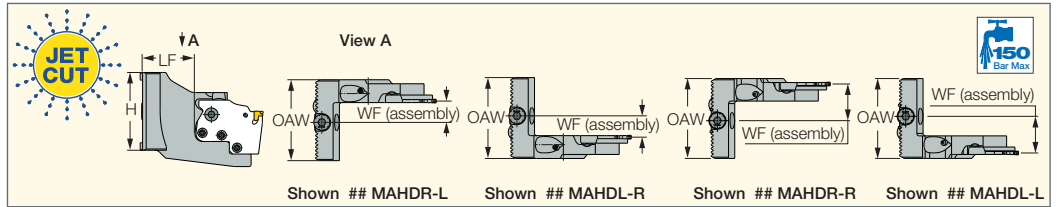

Designation	CSI	H	OAW	LF	WF
V60 MAHDL-L-XL-JHP	V60	62.0	64.50	42.65	29.60
V60 MAHDL-L-XL-SH-JHP	V60	62.0	64.50	18.65	32.80
V85 MAHDL-L-XL-JHP	V85	83.0	85.00	43.65	38.10
V85 MAHDL-L-XL-LH-JHP	V85	83.0	85.00	69.15	38.10
V60 MAHDL-R-XL-JHP	V60	62.0	64.50	42.65	17.00
V60 MAHDL-R-XL-LH-JHP	V60	62.0	64.50	69.15	17.00
V60 MAHDL-R-XL-SH-JHP	V60	62.0	64.50	18.65	20.20
V85 MAHDL-R-XL-JHP	V85	83.0	85.00	43.65	25.50
V85 MAHDL-R-XL-LH-JHP	V85	83.0	85.00	69.15	25.50
V85 MAHDL-R-XL-SH-JHP	V85	83.0	85.00	26.65	25.50
V60 MAHDR-L-XL-JHP	V60	62.0	64.50	42.65	17.00
V60 MAHDR-L-XL-LH-JHP	V60	62.0	64.50	69.15	17.00
V60 MAHDR-L-XL-SH-JHP	V60	62.0	64.50	18.65	20.20
V85 MAHDR-L-XL-JHP	V85	83.0	85.00	43.65	25.50
V85 MAHDR-L-XL-LH-JHP	V85	83.0	85.00	69.15	25.50
V85 MAHDR-L-XL-SH-JHP	V85	83.0	85.00	26.65	25.50
V60 MAHDR-R-XL-JHP	V60	62.0	64.50	42.65	29.60
V60 MAHDR-R-XL-LH-JHP	V60	62.0	64.50	69.15	29.60
V60 MAHDR-R-XL-SH-JHP	V60	62.0	64.50	18.65	32.80
V85 MAHDR-R-XL-JHP	V85	83.0	85.00	43.65	38.10
V85 MAHDR-R-XL-LH-JHP	V85	83.0	85.00	69.15	38.10
V85 MAHDR-R-XL-SH-JHP	V85	83.0	85.00	26.65	41.30

• For user guide, see pages 862-876

For tools, see pages: CGPAD-JHP (309) • DGPAD-JHP (538) • DGPAD-XL-JHP (538) • HGPAD-JHP (291) • PCADR/L-JHP (353) • PCADRS/LS-JHP (354)
 • PCLNR/L-PAD-JHP (25) • PDJNR/L-PAD-JHP (38) • SCLCR/L-PAD-JHP (71) • SDJCR/L-PAD-JHP (78) • SVJCR/L-PAD-JHP (88)
 • TAGPAD-JHP (562) • TAGPAD-XL-JHP (562) • TAGPAD-Y-JHP (584) • TGPAD-JHP (298) • TNFPAD-XL-JHP (668)

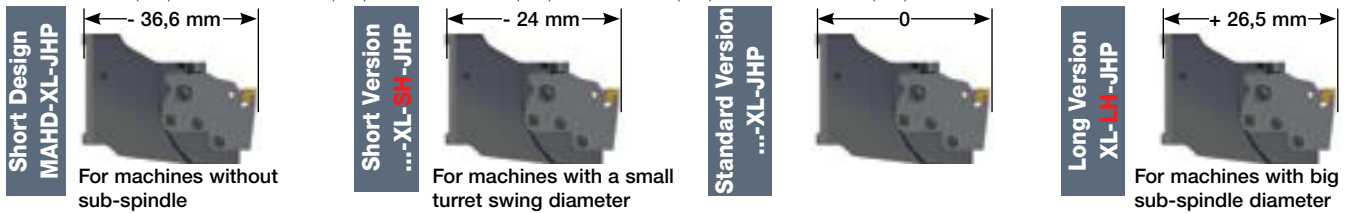

Intermediate holder spare parts

Designation	(1) Clamping Screw	(2) Dummy	(3) Height Adjustment Screw	(4) O-Ring	(5) Screw	(6) Screw	(7) O-Ring
V## MAHD#-#-XL-##-JHP	SR M6x16DIN912 12.9	Dummy-MG-XL-5113377	SR 14-0194-5113373	O RING 8x3 NBR 70	SR M5-04451	SR M6x10DIN6912	OR 5x1N

Tool dimensions with Adapter

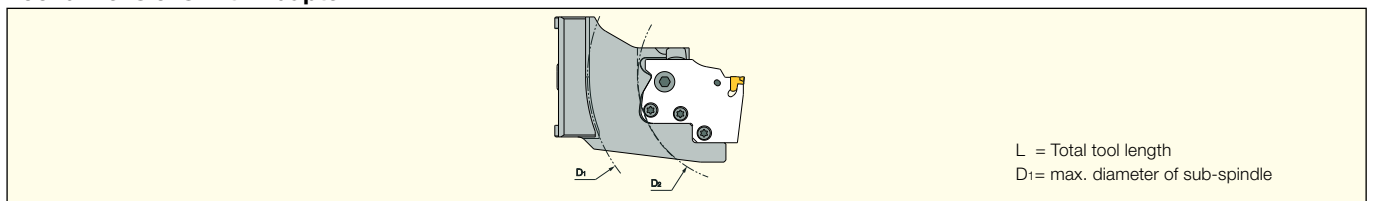

Adapter	V## MAHD#-#- XL-SH-JHP		V## MAHD#-#- XL-JHP		V## MAHD#-#- XL-LH-JHP	
	D1	D2	D1	D2	D1	D2
DGPAD ...-D22-JHP	99	46	147	94	200	147
DGPAD ...-D32-JHP	99	46	147	94	200	147
TAGPAD ...-D42-JHP	104	52	152	100	205	153
TAGPAD ...-D52-JHP	114	62	162	110	215	163
TAGPAD-XL ...-D52-JHP	114	62	162	110	215	163
TAGPAD-XL ...-D65-JHP	127	70	175	118	228	171
TAGPAD-XL ...-D82-JHP	146	86	194	134	247	187
TAGPAD-XL ...-D102-JHP	170	107	218	155	271	208

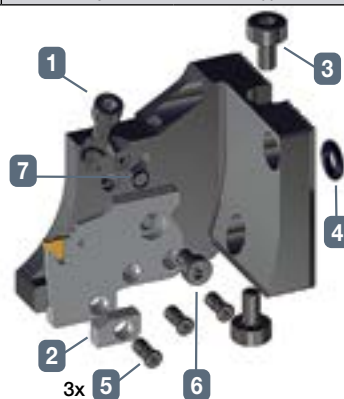

All trademarks and logos are the property of their respective companies

MODULAR-GRIP

V## MAHD-XL-JHP

Intermediate Holders for ISCAR Modular System Holders with Directed Internal Coolant for MODULAR-GRIP-XL Adapters

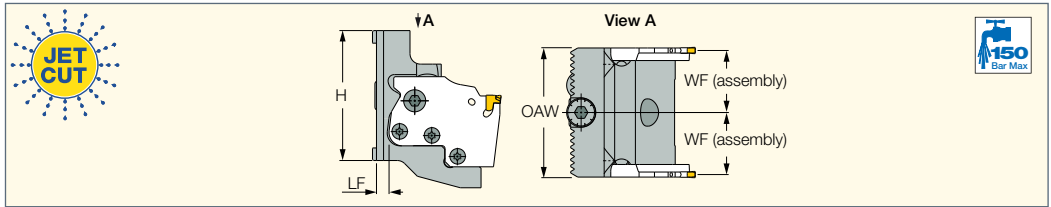

Designation	CSI	H	OAW	LF	WF
V60 MAHD-XL-JHP	V60	62.0	61.60	6.05	29.50
V85 MAHD-XL-JHP	V85	85.0	85.00	6.05	41.30

• For user guide, see pages 862-876

For tools, see pages: CGPAD-JHP (309) • DGPAD-JHP (538) • HGPAD-JHP (291) • PCADR/L-JHP (353) • PCADRS/LS-JHP (354) • PCLNR/L-PAD-JHP (25) • PDJNR/L-PAD-JHP (38) • SCLCR/L-PAD-JHP (71) • SDJCR/L-PAD-JHP (78) • SVJCR/L-PAD-JHP (88) • TAGPAD-JHP (562) • TAGPAD-XL-JHP (562) • TGPAD-JHP (298) • TNFPAD-XL-JHP (668)

LOGIQ FGRIP

V## SQ#-#-D82-JHP

Intermediate Holders for TANG-F-GRIP and DO-F-GRIP Square Type D82 Adapters Designed for Modular Tooling Systems

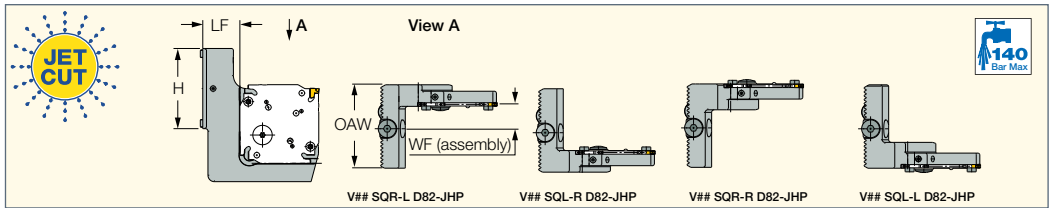

Designation	H	LF	OAW	WF ⁽¹⁾
V60 SQL-L-D82-JHP	62.0	34.70	64.50	28.95
V60 SQL-R-D82-JHP	62.0	34.70	64.50	15.35
V60 SQR-L-D82-JHP	62.0	34.70	64.50	18.85
V60 SQR-R-D82-JHP	62.0	34.70	64.50	32.45
V85 SQL-L-D82-JHP	83.0	34.70	85.00	40.95
V85 SQL-R-D82-JHP	83.0	34.70	85.00	27.35
V85 SQR-L-D82-JHP	83.0	34.70	85.00	27.35
V85 SQR-R-D82-JHP	83.0	34.70	85.00	40.95

⁽¹⁾ When 3mm width insert is used.

For tools, see pages: DGAQ-JHP (580) • DGAQ-JHP (580) • TGAQ (579) • TGAQ-JHP (578)

Identification Legend

V60 SQL-L-D82-JHP

V60 SQL-R-D82-JHP

V60 SQR-L-D82-JHP

V60 SQR-R-D82-JHP

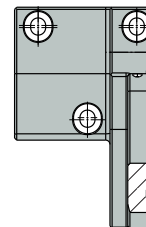
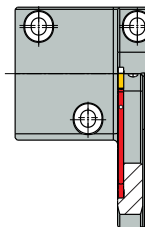
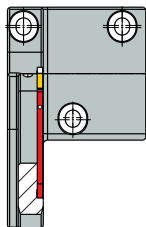
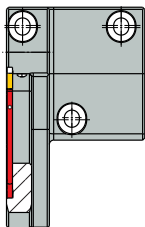
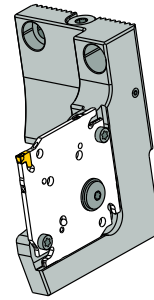
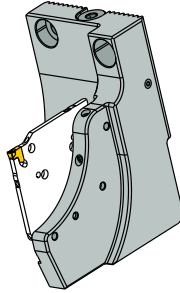
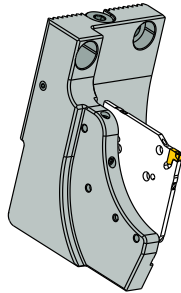
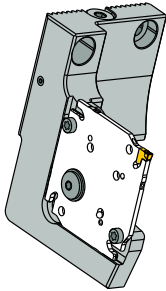

L- Holder (prism) orientation
L- Pocket side

L- Holder (prism) orientation
R- Pocket side

R- Holder (prism) orientation
L- Pocket side

R- Holder (prism) orientation
R- Pocket side

Spare Parts

Designation					
V## SQ#-#-D82-JHP	SR M4X9-SEAL-JHP	JHP COPPER SEAL 1/8"	O-RING 10X2 NBR	SIDE THRUST PIN 3mm	SR M4X10-8.8-T20

All trademarks and logos are the property of their respective companies

JETCROWN
LOGIQ JET COOLANT

V## SQ#-#-D65-ECD

Intermediate Holders for TANG-F-GRIP (TGAQ-ECD) Square D65 Adapters Designed for Modular Tooling Systems

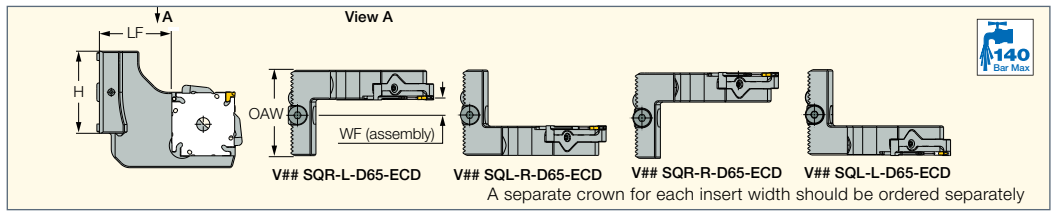

Designation	H	LF	OAW	WF	CUTDIA
V60 SQL-L-D65-ECD	62.0	55.00	64.50	29.30	65.0
V60 SQL-R-D65-ECD	62.0	55.00	64.50	9.80	65.0
V60 SQR-L-D65-ECD	62.0	55.00	64.50	13.30	65.0
V60 SQR-R-D65-ECD	62.0	55.00	64.50	32.80	65.0
V85 SQL-L-D65-ECD	83.0	55.00	85.00	41.30	65.0
V85 SQL-R-D65-ECD	83.0	55.00	85.00	20.80	65.0
V85 SQR-L-D65-ECD	83.0	55.00	85.00	20.80	65.0
V85 SQR-R-D65-ECD	83.0	55.00	85.00	41.30	65.0

NEW

For tools, see pages: TGAQ-ECD (JET-CROWN) (582)

TOOL BLOCKS

V-ASH-MC

Axially Oriented, Short, Right-Hand, Wedge Clamping Holders for Square Shank Tools

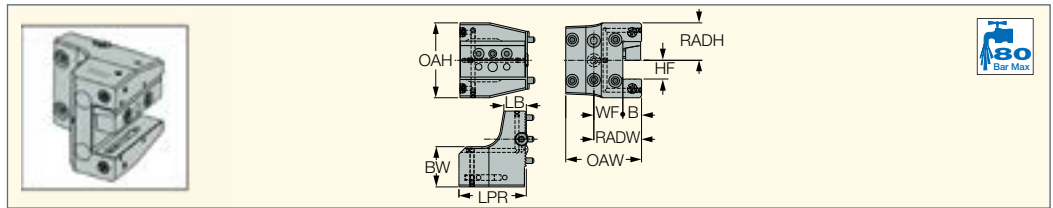

Designation	HF	WF	LPR	OAH	RADW	B	LB	RADH	BW	OAW
V60 ASH 20-MC	20.0	31.00	72.00	80.00	51.00	20.0	24.00	40.00	43.00	81.00
V60 ASH 25-MC	25.0	32.00	87.00	90.00	57.00	25.0	24.00	45.00	48.00	87.00
V85 ASH 25-MC	25.0	43.00	87.00	100.00	68.00	25.0	26.00	50.00	55.00	110.50
V85 ASHD 25-MC	25.0	43.00	87.00	100.00	68.00	25.0	26.00	50.00	55.00	110.50

MODULAR-GRIP

V## V##-L##

Spacer for ISCAR Modular System

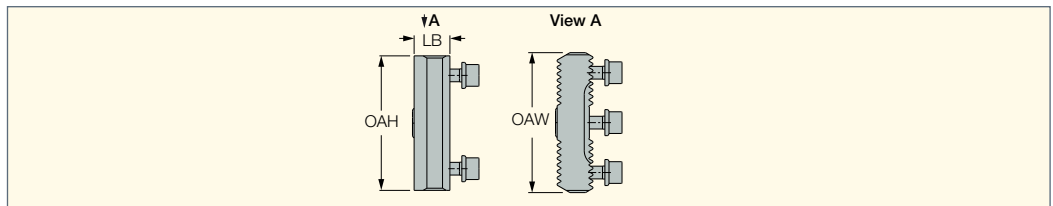

Designation	CSI	OAH	OAW	LB
V60 V60-L15	V60	62.00	64.50	15.00
V60 V60-L30	V60	62.00	64.50	30.00
V85 V85-L30	V85	83.00	85.00	30.00

• For user guide, see pages 862-876



All trademarks and logos are the property of their respective companies



MODULAR-GRIP

TR45 MAHDR-#-XL-JHP
 Toolholders for TRAUB TNK45
 / TNK 65 Machines with
 Directed Internal Coolant for
 MODULAR-GRIP-XL Adapters

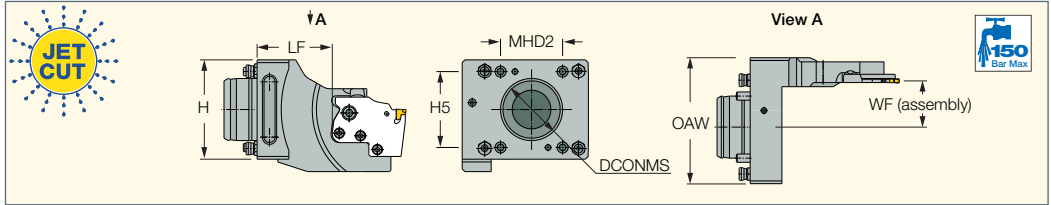

Designation	H	OAW	H5	MHD2	DCONMS	LF	WF
TR45 MAHDR-L-XL-JHP	72.0	91.50	55.00	45.0	45.00	54.40	33.50

• All trademarks and logos are the property of their respective companies • For user guide, see pages 862-876

For tools, see pages: CGPAD-JHP (309) • DGPAD-JHP (538) • HGPAD-JHP (291) • PCADR/L-JHP (353) • PCADRS/LS-JHP (354) • PCLNR/L-PAD-JHP (25)
 • PDJNR/L-PAD-JHP (38) • SCLCR/L-PAD-JHP (71) • SDJCR/L-PAD-JHP (78) • SVJCR/L-PAD-JHP (88) • TAGPAD-JHP (562) • TAGPAD-XL-JHP (562)
 • TAGPAD-Y-JHP (584) • TGPAD-JHP (298)

Spare Parts

Designation	(1) Clamping Screw	(2) Dummy
TR45 MAHDR-L-XL-JHP	SR M6x16DIN912 12.9	Dummy-MG-XL-5113377

(3) Screw	(4) Screw	(5) O-Ring
SR M5-04451	SR M6x10DIN6912	OR 5x1N

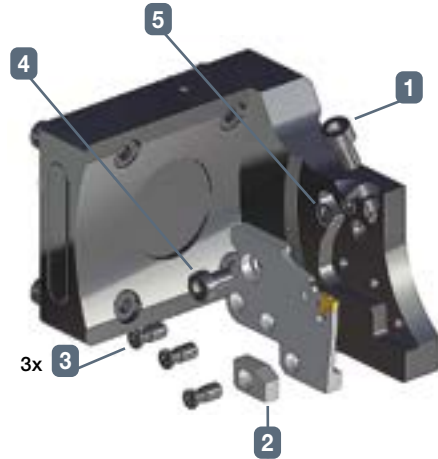

MODULAR-GRIP

TR45TNL MAHDN-R-XL-JHP
 Toolholders for TRAUB TNL16
 to TNL18 / TNL32 Machines
 with Internal Coolant Supply for
 MODULAR-GRIP-XL Adapters

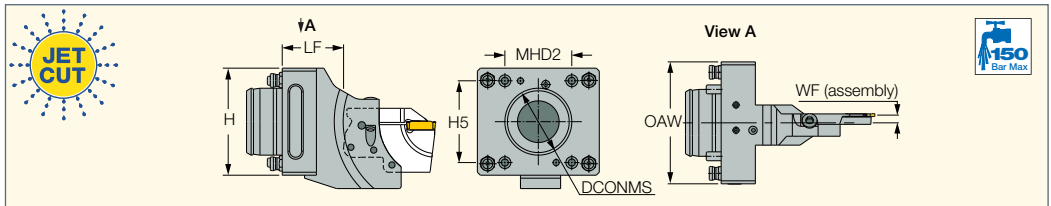

Designation	H	OAW	H5	MHD2	DCONMS	LF	WF
TR45TNL MAHDN-R-XL-JHP	72.0	82.00	55.00	45.0	45.00	41.30	6.00

• All trademarks and logos are the property of their respective companies • For user guide, see pages 862-876

For tools, see pages: CGPAD-JHP (309) • DGPAD-XL-JHP (538) • HGPAD-JHP (291) • PCADR/L-JHP (353) • PCADRS/LS-JHP (354) • PCLNR/L-PAD-JHP (25)
 • PDJNR/L-PAD-JHP (38) • SCLCR/L-PAD-JHP (71) • SDJCR/L-PAD-JHP (78) • SVJCR/L-PAD-JHP (88) • TAGPAD-XL-JHP (562) • TGPAD-JHP (298)

Spare Parts

Designation	(1) Clamping Screw	(2) Dummy
TR45TNL MAHDN-R-XL-JHP	SR M6x16DIN912 12.9	Dummy-MG-XL-5113377

(3) Screw	(4) Screw	(5) O-Ring
SR M5-04451	SR M6x10DIN6912	OR 5x1N

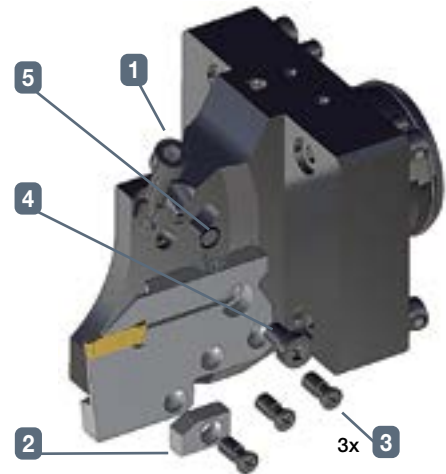



MODULAR-GRIP

TR TNK36 MAHDL-R-XL-JHP
 Toolholders for TRAUB TNK36 / TNL26 Machines with Internal Coolant Supply for MODULAR-GRIP-XL Adapters

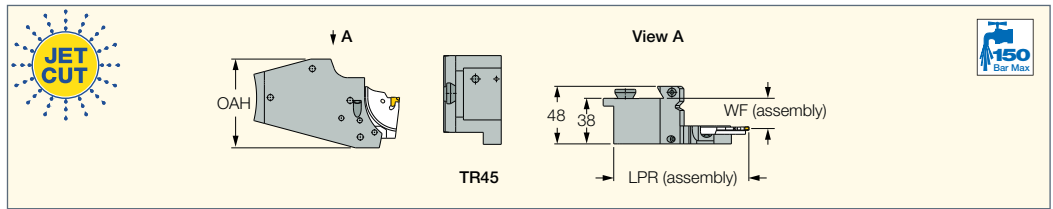

Designation	OAH	LPR	WF
TR TNK36 MAHDL-R-XL-JHP	74.00	91.50	24.50

- All trademarks and logos are the property of their respective companies • For user guide, see pages 862-876
- For tools, see pages:** CGPAD-JHP (309) • DGPAD-XL-JHP (538) • HGPAD-JHP (291) • PCADR/L-JHP (353) • PCADRS/LS-JHP (354) • PCLNR/L-PAD-JHP (25)
- PDJNR/L-PAD-JHP (38) • SCLCR/L-PAD-JHP (71) • SDJCR/L-PAD-JHP (78) • SVJCR/L-PAD-JHP (88) • TAGPAD-XL-JHP (562) • TGPAD-JHP (298)
- TNFPAD-XL-JHP (668)

Spare Parts

Designation	(1) Clamping Screw	(2) Dummy	(3) Screw	(4) Screw	(5) O-Ring
TR TNK36 MAHDL-R-XL-JHP	SR M6x16DIN912 12.9	Dummy-MG-XL-5113377	SR M5-04451	SR M6x10DIN6912	OR 5x1N

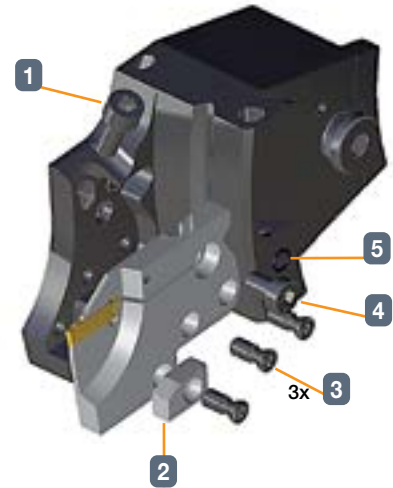

INDEX

MODULAR-GRIP

ABC MAHDR-#-XL-JHP
 Toolholders for Index ABC Speedline with Internal Coolant Supply for MODULAR-GRIP-XL Adapters

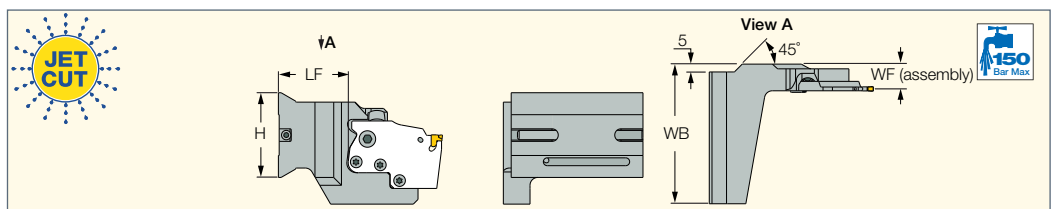

Designation	H	WB	LF	WF
ABC MAHDR-L-XL-JHP	56.0	91.50	44.55	17.00

- All trademarks and logos are the property of their respective companies • For user guide, see pages 862-876
- For tools, see pages:** CGPAD-JHP (309) • DGPAD-JHP (538) • DGPAD-XL-JHP (538) • HGPAD-JHP (291) • PCADR/L-JHP (353) • PCADRS/LS-JHP (354)
- PCLNR/L-PAD-JHP (25) • PDJNR/L-PAD-JHP (38) • SCLCR/L-PAD-JHP (71) • SDJCR/L-PAD-JHP (78) • SVJCR/L-PAD-JHP (88) • TAGPAD-JHP (562)
- TAGPAD-XL-JHP (562) • TAGPAD-Y-JHP (584) • TGPAD-JHP (298) • TNFPAD-XL-JHP (668)

Spare Parts

Designation	(1) Clamping Screw	(2) Dummy	(3) Screw	(4) Screw	(5) Pin
ABC MAHDR-#-XL-JHP	SR M6x16DIN912 12.9	Dummy-MG-XL-5113377	SR M5-04451	SR M6x10DIN6912	SR M4x5DIN913 45H

Designation	(6) Stopper Screw	(7) Height Adjustment Screw	(8) O-Ring
ABC MAHDR-#-XL-JHP	DIN913-M6x80-45H	SR M5x8DIN913 45H	OR 5x1N

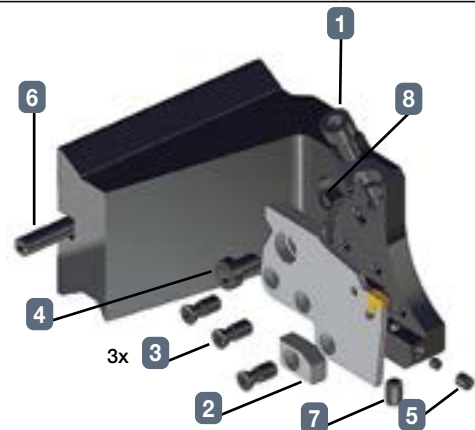

All trademarks and logos are the property of their respective companies

MATERIALS AND GRADES

YOU

INTELLIGENTLY?

MACHINING

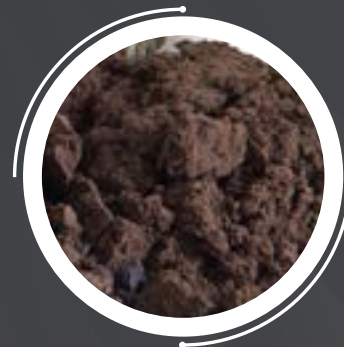

MATERIAL GROUPS

Based on ISO 513 and VDI 3323 standards

ISO	Material	Condition	Tensile Strength [N/mm ²]	Kc1 ⁽¹⁾ [N/mm ²]	mc ⁽²⁾	Hardness HB	Material Group No.	
P	non-alloy steel and cast steel, free cutting steel	<0.25% C	annealed	420	1350	0.21	125	1
		≥0.25% C	annealed	650	1525	0.22	190	2
		<0.55% C	quenched and tempered	850	1675	0.24	250	3
		≥0.55% C	annealed	750	1675	0.24	220	4
			quenched and tempered	1000	1900	0.24	300	5
	low alloy and cast steel (less than 5% of alloying elements)	annealed		600	1775	0.24	200	6
				930	1675	0.24	275	7
		quenched and tempered		1000	1725	0.24	300	8
				1200	1800	0.24	350	9
	high alloyed steel, cast steel and tool steel	annealed	680	2450	0.23	200	10	
		quenched and tempered	1100	2500	0.23	325	11	
	stainless steel and cast steel	ferritic / martensitic	680	1875	0.21	200	12	
		martensitic	820	1875	0.21	240	13	
M	stainless steel and cast steel	austenitic, duplex	600	2150	0.20	180	14	
K	gray cast iron (GG)	ferritic / pearlitic		1150	0.20	180	15	
		pearlitic / martensitic		1350	0.28	260	16	
	nodular cast iron (GGG)	ferritic		1225	0.25	160	17	
		pearlitic		1350	0.28	250	18	
	malleable cast iron	ferritic		1225	0.25	130	19	
		pearlitic		1420	0.3	230	20	
N	aluminum-wrought alloys	not hardenable		700	0.25	60	21	
		hardenable		800	0.25	100	22	
	aluminum-cast alloys	≤12% Si	not hardenable		700	0.25	75	23
			hardenable		700	0.28	90	24
		>12% Si	high temperature		750	0.25	130	25
	copper alloys	>1% Pb	free cutting		700	0.27	110	26
			brass		700	0.27	90	27
			electrolytic copper		700	0.27	100	28
	non metallic	duroplastics, fiber plastics			200	0.20	70 Shore D	29
		hard rubber			200	0.20	55 Shore D	30
S	high temperature alloys	Fe based	annealed		2600	0.24	200	31
			hardened		3100	0.24	280	32
		Ni or Co based	annealed		3300	0.24	250	33
			hardened		3300	0.24	350	34
			cast		3300	0.24	320	35
	titanium alloys	pure		400	1160	0.24	190	36
		alpha+beta alloys, hardened		1050	1245	0.24	310	37
H	hardened steel	hardened			4600	0.25	55 HRC	38
		hardened			4700	0.25	60 HRC	39
	chilled cast iron	cast			4600	0.27	400	40
	cast iron	hardened			4500	0.27	55 HRC	41

- steel
- stainless steel
- cast iron
- non-ferrous metals
- superalloys and titanium
- hard materials

⁽¹⁾ Specific cutting force for 1 mm² chip section







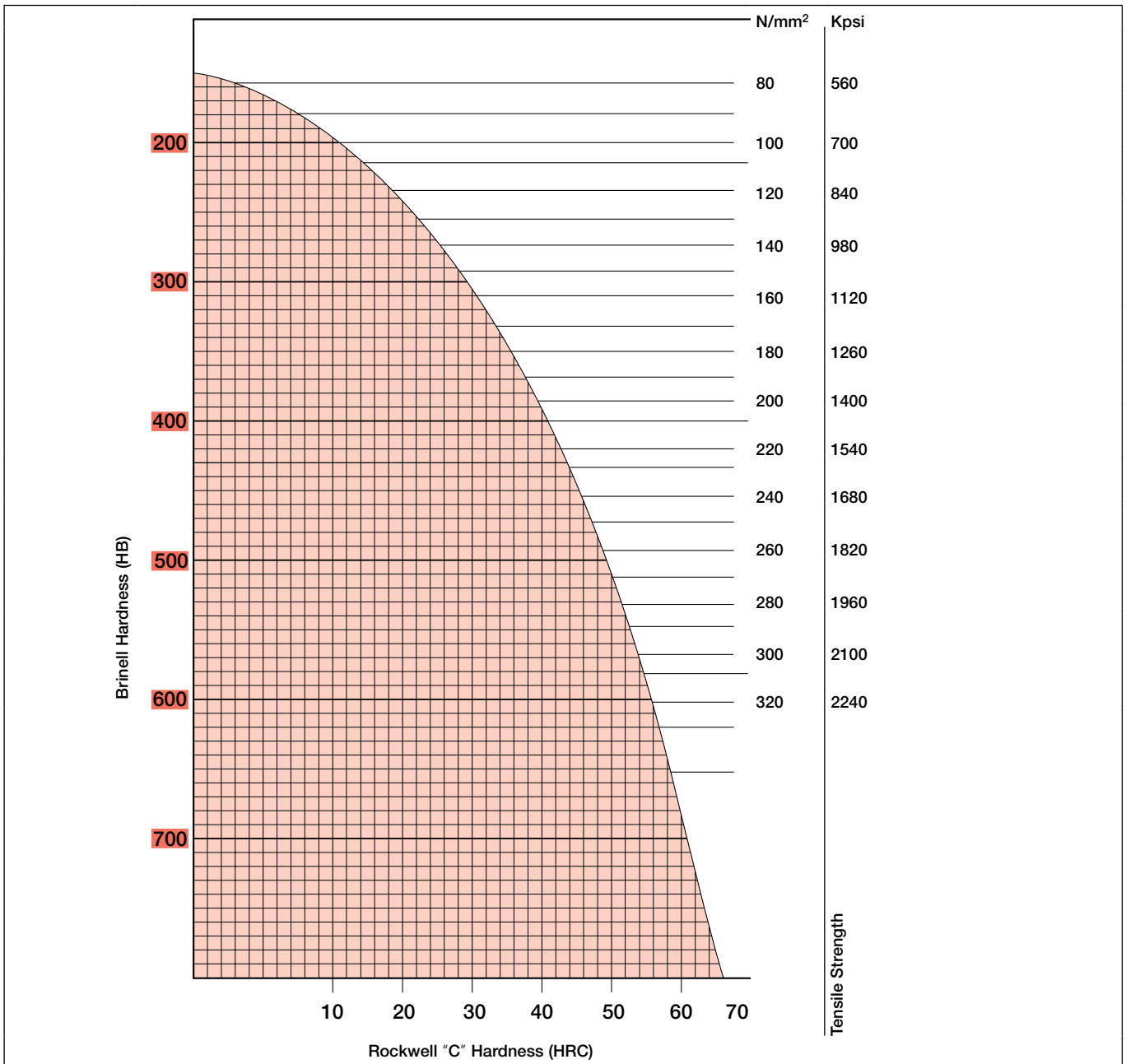





⁽²⁾ Chip thickness factor

MATERIAL GROUPS















Hardness Conversion Table



Material Designation in Accordance with Selected Standards

Standards		Material Group No.									
		1	1	1	1	1	1	1	1	1	1
	NF/AFNOR (FRANCE)	E 28-2	A 50-2	E 36-2	E 28-3	SPH 265; A 42 AP	E	E 28-3; E 28-4	C; TC	E 24-2	A 33
	AISI/ASM/ASTM/SAE/UNS/AA (US)	1020; G10200; K02301; K02595; K02596; K02597; K02598; K02599; K02702; K0300		K02404; K02702	K02702		A 619	K02601; K03000; A 573 Gr. 70; A 611 Gr.D	1008; G10080; A 621	1015; G10150; K02401	
	BS (UK)	En 43 B; Fe 430 B FN; 43/25 HR; 43/25HS; 43 B; HPW4; HFS4; ERW 3	Fe 490-2 FN; 50 B	50 B; 4360-50 B	43C; 4360-43C	164-400B LT 20	2 CR; 3 CR	Fe 430 D1 FF; 4360-43 C; 4360-43 D	CR 4; CS 4	Fe 360 B; 4360-40 B; ERW 3; CEW 3; 37/23 HR; 37/23 HS; 37/23 CR; 37/23 CS	Fe 310-0; 15 HR; 15 HS; 1449 15 HR; 1449 15 HS
	DIN (GERMANY)	S275JR; St 44-2; Fe 430 B; S275J2G3	E295; St 50-2; Fe 490-2; ST 50-2 G (E295+CR)	S355JR; Fe 510 B	S275J0; St 44-3 U; Fe 430 C	P265S; SPH 265	DC03G1; UST 3; USt 13	S275J2G3 (S275J2); St 44-3 (Fe 430 D 1)	DC01; DC 01; St 2; St 12	S235JR (Fe 360 B); St 37-2	S185 (Fe 310-0); St 33
	Werkstoff (GERMANY)	1.0044	1.0050	1.0045	1.0143	1.0130	1.0333	1.0144	1.0330	1.0037	1.0035
	EN (EUROPE)	S275JR		S355JR	S275J0	P265S	DC03G1		DC01 (FeP 05)		S185
	GOST (RUSSIA)	St4ps; St4sp	St5ps; St5sp					St4kp; St4ps; St4sp			St0
	JIS (JAPAN)	SN 400 B; SN 400 C; SN 490 B; SN 490 C; SS 400; STK 400; STKM 19 C; STKR 400; 19 C; SS 41; STK 41	SS 490; SS 50	SN 400 B; SN 400 C; SN 490 B; SN 490 C; SS 490; SS 50			SPCD	SM 400 A; SM 400 B; SM 400 C; SS 400; STK 400; STKR 400; SM 41 A; SM 41 B; SM 41 C	SPCC; CR 1	STKM 12 A; STKM 12 AC	SGP; SS 330; SS 34
	SS (SWEDEN)	1411; 1412	1550; 2172		1414-01			1411; 1412; 1414	1142	1311	1300
	UNE (SPAIN)	AE 275 B; Fe 430 B FN	A 490-2; Fe 490-2 FN	AE 355 B	AE 275 D	SPH 265	AP 02	AE 275 D; Fe 430 D1 FF	AP 11; FeP 01; AP 00	AE 235 B; Fe 360 B	Fe 310-0; A 310-0
	UNI (ITALY)	Fe 430 B FN; Fe 430 B	Fe 490	Fe 510 B FN	Fe 430 C FN		FeP 02	Fe 430 B; Fe 430 C (FN); Fe 430 D (FF)	FeP 01; FeP 00	Fe 360 B; 1449 37/23 HR	Fe 320
	IS (INDIA)		Fe 490	IS 961	Fe410WA			Fe410WC	IS 513/94 O		
	KS (REP. OF KOREA)	SB 41	SS 490	SS 490			SPCD	SWS 41C; SWS 4 B; SWS 41A; SM 400A; SM 400B; SM 400C		STKM 12A; STKM 12C	SS 330
	GB/YB/JB/SY/NB (PRC)	Q255A; Q255D	Q295A	Q345B	Q275	20	10F	Q275	8	15	Q195







Material Designation in Accordance with Selected Standards

Standards		Material Group No.									
		1	1	1	1	1	1	1	1	1	1
	NF/AFNOR (FRANCE)	A 34-2 NE	2 C	3 C	ES	A 37 CP	C10RR; XC 10; C 10; AF 34 C 10	E 28-3	GC	E 24-3	
	AISI/ASM/ASTM/SAE/UNS/AA (US)	K02502		1006; G10060	A 620	K01700; K02001; K02200; K02201; K02203; K02503; K02601; K02801	1010; G10100			A 1011 (SS Grade 36 (230) Type 2); A1011 (SS Grade 36 (250) Type 1)	A572-60
	BS (UK)	CEW 2; 34/20 HR; 34/20 HS; 34/20 CR; 1449 34/20CS		1 CR; 1 CS; 1 HR; 2 HR; 2 HS; 2 CR; 2 CS	CR 1; CR 2	141-360; 151-360; 154-360; 161-360; 164-360	040 A 10; 045 M 10; En 2 A; En 2 A/1; En 2 B; En 32 A; 10 CS	43 C; 4360-43C	Z2	40 C; 4360-40C	4360 55 E
	DIN (GERMANY)	E195; RSt 34-2	DD12G1; UStW 23	DD13; StW 24	DC04; St 4; St 14	P235GH; Hl; H I	C10; C 10	S275JOH; St 44-3 U; RoSt 44-2	DX51D; St 02 Z	S235JO; St 37-3 U; Fe 360 C	S380N; StE 380
	Werkstoff (GERMANY)	1.0034	1.0334	1.0335	1.0338	1.0345	1.0301	1.0149	1.0226		1.8900
	EN (EUROPE)	E195		DD13	DC04 (FeP 04)	P235GH	C10	S275JOH		S235JO	S380N
	GOST (RUSSIA)	St2ps; St2sp	10kp	08kp	08JuA		10				
	JIS (JAPAN)		SPHD	SPHE	SPCE; HR 4	SGV 410; SGV 450; SGV 480; SPV 235; SPV 450; SPV 490; SGV 42; SGV 46; SGV 49; SPV 24; SPV 46; SPV 50	S 10C		SGC C	SS 330; SS 34	S 25 C
	SS (SWEDEN)				1147	1330; 1331		1412-04	1151 10		2145
	UNE (SPAIN)		AP 12	AP13	AP 04; FeP 04	A 37 Grado RA II; A 37 Grado RC I	F.151; F.151.A	Fe 430 C; AE 275 C	FeP 02 G	AE 235 C	
	UNI (ITALY)	Fe 330 BFN	FeP 12	FeP 13	FeP 04	FeE 235; Fe 360 1 KW; Fe 360 1 KG; Fe 360 2 KW; Fe 360 2 KG	1 C 10; C 10	Fe 430 C	FeP 02 G	Fe 360 C FN	FeE 390 KG
	IS (INDIA)					IS 2002 Grade 1	5C4			Fe410-S	
	KS (REP. OF KOREA)		SPHD	SPHE	SPCE	SPV 24; SGV 49; SGV 46; SGV 42; SGV 410; SGV 450; SGV 480	SM 10C			SS 330	SM 25C
	GB/YB/JB/SY/NB (PRC)	Q215B	Q195	08F		A3R	10			Q195	















Material Designation in Accordance with Selected Standards

Standards		Material Group No.								
		1	1	1	1	1	1	1	1	1
	NF/AFNOR (FRANCE)	A 60-2	A 34-2	A 37 AP; SPH 235	10 PbF 2	10 F 2	S 250 Pb	S 250	XC 25; XC 18; 2 C 22	E 560 D; S 560 MC
	AISI/ASM/ ASTM/SAE/ UNS/AA (US)	A 572 Gr. 65		K01700; K02200; K02801		1108; 1109; 1111; B 1111; B 1111; G11080; G11090	12L13; 12L14; 12 L 13; 12 L 14; G12134; G12144	1213; 1215; G12130; G12150	1020; 1023; G10200; G10230	A 1008 (HSLAS-F Grade 80 [550]); A 1011 (HLAS-F Grade 80 [550])
	BS (UK)	En 55 C; Fe 590-2-FN; 55 E; 4360-55 E		164-360B LT20; 1501-164-360B LT20			230 M 07 Pb; En 1A Pb	230 M 07; En 1 A	055 M 15; 070 M 20; En 3 A; En 3 C; En 2	60F55 HR; 60F55 HS; 60F55 CS
	DIN (GERMANY)	E335; St 60-2 (Fe 590-2 B)	S250G1T; USt 34-2	P235S; SPH 235	10SPb20; 10 SPb 20	10S20; 10 S 20	11SMnPb30; 9 SMnPb 28	11SMn30; 9 SMn 28	C22E; Ck 22	S500MC; QStE 500 TM
	Werkstoff (GERMANY)	1.0060	1.0028	1.0112	1.0722	1.0721	1.0718	1.0715	1.1151	1.0986
	EN (EUROPE)	E335		P235S	10SPb20	10S20	11SMnPb30	11SMn30	C22E	S500MC
	GOST (RUSSIA)	St6ps; St6sp							20	
	JIS (JAPAN)	SM 570; SM 58	SS 330; SS 34				SUM 22 L; SUM 23 L; SUM 24 L	SUM 22	S 20 C; S 20 CK; S 22 C	
	SS (SWEDEN)	1650					1914	1912	1450	
	UNE (SPAIN)	A 590; Fe 590-2 FN		AE 235 C	10 SPb 20; F.2122	10 S 20; F. 2121	F.210.C; F.210.M; 11 SMnPb 28; F.2112	F.210.A; F.210.L; 11 SMn 28; F.2111	F.1120; C 25 K	
	UNI (ITALY)	Fe 590; Fe 60-2	Fe 330; Fe 330 B FU	Fe 360 C	CF 10 SPb 20	CF 10 S 20	CF 9 SMnPb 28	CF 9 S 22	C 20; C 25	FeE 560 TM
	IS (INDIA)	St 58						10C14S14	20C8	
	KS (REP. OF KOREA)	SM 570	SS 330				SUM 23 L; SUM 24 L	SUM 22; SUM 24L	S 20C; S 22C; S 20CK	
	GB/YB/JB/ SY/NB (PRC)	Q235C	Q215A			Y12		Y15	20	

Material Designation in Accordance with Selected Standards

Standards		Material Group No.			
		1	1	1	1
	NF/AFNOR (FRANCE)	E 490 D; S 490 MC		E 355 D	E 315 D
	AISI/ASM/ ASTM/SAE/ UNS/AA (US)	A 1008 (HSLAS-F Grade 70 [480]); A 1008 (HSLAS Grade 70 [480] Class 1)	A 1008 (HSLAS Grade 65 [450] Class 1); A 1008 (HSLAS Grade 65 [450] Class 2)	A 1008 (HSLAS Grade 50 [340] Class 1); A 1008 (HSLAS Grade 50 [340] Class 2)	A 1008 (HSLAS Grade 50 [340]); A 1008 (HSLAS Grade45 [310] Class 2); A 1011 (HSLAS-F Grade 50 [340])
	BS (UK)		1501-50F45; 50F45 HR; 50F45 HS; 50F45 CS	46F40 HR; 46F40 HS; 46F40 CS	1501-40F30; 43F35 HR; 43F35 HS; 43F35 CS
	DIN (GERMANY)	S500MC; QStE 500 TM	S460MC; QStE 460 TM	S355MC; QStE 360 TM	S315MC; QStE 300 TM
	Werkstoff (GERMANY)	1.0984	1.0982	1.0976	1.0972
	EN (EUROPE)	S500MC	S460MC	S355MC	
	GOST (RUSSIA)				
	JIS (JAPAN)				
	SS (SWEDEN)	2662		2642	
	UNE (SPAIN)				
	UNI (ITALY)	FeE 490 TM		FeE 355 TM	
	IS (INDIA)				
	KS (REP. OF KOREA)				
	GB/YB/JB/ SY/NB (PRC)				















Material Designation in Accordance with Selected Standards

Standards		Material Group No.								
		1	1	1	1	1	1	1	1	1
	NF/AFNOR (FRANCE)	FeE 355 KG N; E 355 R/FP; A 510 AP		A 510 FP	A 510 AP		E 36-3	TSE 355-3; E 36-3		AF 42 C 20; XC 25; 1 C 22
	AISI/ASM/ ASTM/SAE/ UNS/AA (US)	K01600; K02007; K02700; K02701; K02803; K02900; K03009; K03300; K11803; K12000; K12001; K12037	1024; K03011; K03014; K12037; K12709	K01600; K02302; K02700; K02701; K02803; K03301; K11803; K12037; K12609; A 299 (A); A 299 (B)	K01600; K02007; K02701; K02803; K117803; K12001; K12037; K12609	K12037	K12000	A 252 (1); A 252 (2); A 252 (3)	K02502	1020; 1022; 1023; G10200; G10220; G10230
	BS (UK)	225-490A		225-490 A	225/490; 225-490 A; 500 Nb	50 EE	50 C; 4360-50C	50 C; 4360-50C	Fe 360 B FU; Fe 360 B FN	055 M 15; 070 M 20; En 3 A; En 3 B; En 3 C; En 2; 22 HS; 22 CS
	DIN (GERMANY)	P355N; StE 355	S355J2G3 (S355J2); St 52-3 N (Fe 510 D1)	P355NL1; TStE 355	P355NH; WStE 355	S355 NLH; TStE 355	S355JO; St 52-3 U; Fe 510 C	S355JOH; St 52-3 U	S235JRG1; S235JR; Fe 360 B; UST 37-2	C22
	Werkstoff (GERMANY)	1.0562	1.0570	1.0566	1.0565	1.0549	1.0553	1.0547	1.0036	1.0402
	EN (EUROPE)	P355N	S355J2G3	P355NL1	P355NH	S355 NLH	S355JO	S355JOH		C22; 2C/2D
	GOST (RUSSIA)	15GF	17GS; 17G1S						16D; St3Kp	20
	JIS (JAPAN)	SM 490 A; SM 490 B; SM 490 C; SM 490 YA; SM 490 YB; SM 490YB STK 490 YB; STK 490; STK 500; SM 50 A; SM 50 B	SM 490 A; SM 490 B; SM 490 C; SM 490 YA; SM 490 YB; SM 520 B; SM 520 C; STK 490; STK 500; STKM 16 C	SLA 365; STK 490; STK 500; SLA 37; STK 50; STK 51			SCC 3			S 20 C; S 22 C
	SS (SWEDEN)	2106	2132; 2134	2107	2106	2135			1311; 1312	1450
	UNE (SPAIN)	AE 355 KG; AE 355 DD	AE 355 D; Fe 510 D1 FF			FeE 355 KTM	AE 355 C	AE 355 C; Fe 510 C	AE 235 B; Fe 360 B	F.112; 1 C 22
	UNI (ITALY)	FeE 355; FeE 355 KG; FeE 355 KW	Fe 510	Fe E 355 KT	FeE 355-2; FeE 355 KW	Fe 510 D	Fe 510 C FN	Fe 510 C	Fe 360 B; Fe 360 C; Fe 360 D	C 20; C 21
	IS (INDIA)		Fe540WHT						IS226	
	KS (REP. OF KOREA)	SM 490A; SM 490 ; SM 490C; YA; YB	SM 490A; SM 490B; SM 490C; YA; YB							SM 20C; SM 20CK
	GB/YB/JB/ SY/NB (PRC)		20Mn2				Q345C		Q235B	20Mn















Material Designation in Accordance with Selected Standards

Standards		Material Group No.									
		1	1	1	1	1	1	1	1	1	1
	NF/AFNOR (FRANCE)	A 42 CP; A 42 AP	E 23-45 M	E 355 FP	E 355 R	S355NH; TSE 355-4	S 250	10 PbF 2	S 300	S 300 Pb	C10RR; XC 10
	AISI/ASM/ ASTM/SAE/ UNS/AA (US)	K01701; K02505; K02704; K02801	A27 65-35	K12000; K12037	K12709	K02705; K02305; K12709	1213; 1215; G12130; G12150		1215; G12150; A 29 (1215); A 108 (1215); A 510 (1215); A 519 (1215); A 521 (1215)	12L14; 12 L 14; G12144	1010; G10100
	BS (UK)	151-400; 154-400; 161-400; 164-400		50 EE; 4360-50EE	50 E; 4360-50E	S355NH	230 M 07; 220 M 07				040 A 10; 045 M 10; En 2 A; En 2 A/1; En 2 B; En 32 A
	DIN (GERMANY)	P265GH; H II	HX300PD; H300PD; H 300 PD	S355NL; TSIE 355	S355N; StE 355	S355NH; StE 335 N	11SMn30; 9 SMn 28	10SPb20; 10 SPb 20	11SMn37; 9 SMn 36	11SMnPb37; 9 SMnPb 36	C10E; Ck 10
	Werkstoff (GERMANY)	1.0425	1.0443	1.0546	1.0545	1.0539	1.0715	1.0722	1.0736	1.0737	1.1121
	EN (EUROPE)	P265GH	HX300PD		S355N	S355NH	11SMn30	10SPb20	11SMn37	11SMnPb37	C10E
	GOST (RUSSIA)	16K; 20K									08; 10
	JIS (JAPAN)	SG 295; SGV 410; SGV 450; SGV 480; SPV 315; SPV 355; SG 30; SGV 42; SGV 46; SGV 49; SPV 32; SPV 36			SM 490 A; SM 490 B; SM 490 C; SM 490 YA; SM 490 YB; SM 50 A; SM 50 B; SM 50 C; SM 50 YA; SM 50 YB		SUM 22		SUM 25		S 09 Ck; S 10 C
	SS (SWEDEN)	1431; 1430; 1432	1305	2135; 2135-01	2134	2134-04	1912			1926	1265
	UNE (SPAIN)	A 42 Grado RC I; A 42 Grado RC II; F.6306; F.6307		AE 355 Grado KT	AE 355 Grado KG	Fe 355 KGN	F.210.A; F.210.L; 11 SMn 28; F.2111	10 SPb 20; F.2122	12 SMn 35; F.2113	12 SMnPb 35; F.2114	C 10 k; F.1510
	UNI (ITALY)	Fe 410 1 KW; Fe 410 1 KG; Fe 410 1 KT; Fe 410 2 KW; Fe 410 2 KG		FeE 355 KT	FeE 355 KG	Fe 510 B	CF 9 S 22	CF 10 SPb 20	CF 9 Mn 36	CF 9 SMnPb 36	2 C 10; 2 C 15; 1 C 10; C 10
	IS (INDIA)	IS 2002 Grade 2B					11C10S25				10C4
	KS (REP. OF KOREA)	SPPV 32; SGV 49; SGV 46; SGV 42; SGV 410; SGV 450; SGV 48; SPV 450; SPV 480					SUM 22		SUM 25		S 10 C
	GB/YB/JB/ SY/NB (PRC)	16Mn					Y15		Y13		08



Material Designation in Accordance with Selected Standards

Standards		Material Group No.										
		1	1	1	1	1	1	1	1	1	1	1
	NF/AFNOR (FRANCE)	XC 12; XC 15; XC 18	E 28 A; NFA 35-501 E 28	S 320 GD		ES	E 24-3; E 24-4; E 24-U	C18RR; XC 18; C 18; AF 37 C 12	E	E 24-2 NE		
	AISI/ASM/ ASTM/SAE/ UNS/AA (US)	1015; 1017; G10150; G10170	1020; G10200; K02301; K02595; K02596; K02597; K02598; K02599; K02702; K03000				K02001; K02601; K02701	1015; 1017; G10150; G10170		K01500; K01702; K02401; K02502; K03000; A570.36	J03001	1117; C1117; G11170
	BS (UK)	080 A 15; 080 M 15; En 32 C	En 43 B; Fe 430 B; 43/25 HR; 43/25 HS; 43 B; HFW 4; HFS 4; ERW 3; CEW 4; SAW 4			CR 1; CS 2	Fe 360 D1 FF; 37/23 CR; 37/23 CS; 37/23 HR; 37/23 HS; 40 D; HFW 4; HFS 4	080 A 15; 080 M 15; En32 C; 17 CS; 17 HS	CR2; CR3; CS3; 1449 3 CR; 1449 2 CR	Fe 360 B FU; 37/23 CR; 37/23 CS; 37/23 HR; 37/23 HS; HFW 3; HFS 3; 40 B	A 1	
	DIN (GERMANY)	C15E; Ck 15	S275JR; St 44-2; Fe 430 B	S320GD; StE 320-3 Z	P265NL; P 265 NL	DC04; St 4; St 14	S235J2G3 (S235J2); St 37-3 N; Fe 360 D 1	C15; C 15	DC03; RRSt; RRSt 13	S235JR; S235JRG2; RSt 37-2; Fe 360 B	GE240; GS-45	18S10; 15SMn13
	Werkstoff (GERMANY)	1.1141	1.0044	1.0250	1.0453	1.0338	1.0116	1.0401	1.0347	1.0038	1.0446	1.0712; 1.0725
	EN (EUROPE)	C15E	S275JR	S320GD	P265NL	DC04	S235J2G3	C15	DC03	S235JR	GE240	18S10; 15SMn13
	GOST (RUSSIA)	15	St4ps; St4sp			08JuA	16D; St3sp		08Ju	St3ps; St3sp	25L-3	
	JIS (JAPAN)	S 15 C; S 15 CK	SN 400 B; SN 400 C; SN 490 B; SN 490 C; SS 400; STK 400; STKM 19 C; STKR 400; 19 C; SS 41; STK 41	SGC 440; SZAC 440; SZA4 440; SGLH 440		SPCE; HR 4	SS 330; SS 34	S 15 C	SPCD; CR 3	SS 330; SS 34	230-450; 230-450 W	
	SS (SWEDEN)	1370	1411; 1412			1147	1312; 1313	1350	1146	1312		
	UNE (SPAIN)	C 16 k; F.1511; F.1110; C 15 k	AE 275 B; Fe 430 B FN			AP 04; FeP 04		F.111	AP 02; AP02; FeP03	AE 235 B FN; AE 235 B FU; Fe 360 B FN; Fe 360 B FU		
	UNI (ITALY)	1 C 15; C 15	Fe 430 B FN			FeP 04	Fe 360 C; D; Fe 360 C FN; Fe 360 D FF; Fe 37-2	1 C 15; C15; C16	FeP 02; FeP 03	Fe 360 B FN		
	IS (INDIA)	15C4						15C4				
	KS (REP. OF KOREA)	SM 15C; SM 15CK	SB 41			SPCE	SS 330	SM 15C	SPCD	SS 330		SS 330
	GB/YB/JB/ SY/NB (PRC)	15	Q255A ; Q255D				Q195	15		Q235C	ZG230-450	Q215A















Material Designation in Accordance with Selected Standards

Standards		Material Group No.												
		1	1	1	2	2	2	2	2	2	2	2	2	
	NF/AFNOR (FRANCE)	E24-4	14-13-12E		C 35; AF 55; 1 C 35; XC 38	XC 38 TS	35 M 5	AF 60; C 40; 1 C 40	C45RR; XC 45; XC 48 H-1	2 C 25; XC 25	C 45; AF 65; C 45; 1 C 45	XC 48 TS	35 MF 4	45 MF 4
	AISI/ASM/ASTM/SAE/UNS/AA (US)	A 36	1018; G10180; 5069D		1035; G10350	1035; G10350	1039; G10390	1040; G10400	1045; 1045 H; 1042; G10450; H10450; G10420	1025; G10250	1043; 1045; G10430; G10450	1050; 1055; G10500; G10550	1140; G11400	1139; 1146; G11390; G11460
	BS (UK)	En 40 D	43A		080 M 30; En 5; 080 M 36	080 A 35		En 8; 080 M 40	080 H 46; 080 M 46	070 M 26	080 M 46		212 M 36	
	DIN (GERMANY)	S235J2; S235J2G4	L355; RSt 44-2	C15R; C15RPb; Cm 15	C35G; C 35 G	C35G; C 35 G; Cf 35	40Mn4; 40 Mn 4	C40; C 40	C45E; Ck 45	C25E; Ck 25	C45; C 45	C53G; C53E; Cf 53	35S20; 35 S 20	46S20; 45 S 20
	Werkstoff (GERMANY)	1.0117	1.0419	1.1140	1.0501	1.1183	1.1157	1.0511	1.1191	1.1158	1.0503	1.1213	1.0726	1.0727
	EN (EUROPE)	S235J2	L355	C15R; C15RPb	C35G	C35G		C40	C45E	C25E	C45		35S20; 8M	46S20
	GOST (RUSSIA)		St3sp			35	40G		45	25	45	50		
	JIS (JAPAN)	SS 330; SS 34	SWRCH 18 A; SWRCH 18 K; SWRCH 19 A		S 35 C; S 35 CM	S 35 C; S 35 CM			S 45 C; S 45 CM; S 48 C	S 25 C; S 28 C	S 45 C; S 45 CM	S 50 C; S 50 CM		
	SS (SWEDEN)	1313			1572; 1550	1572			1672		1650		1957	
	UNE (SPAIN)				F.113	F.1130; C 35 k		F.114.A	F.1140; F.1142; C 45 k; C48 k	F.1120; C 25 k	F.114		F.210.G; 35 MnS 6; F.2131	
	UNI (ITALY)	Fe 360 D			C 35; 1 C 35	C 36; C 38		C 40; 1 C 40	C 45	C 25	C 45; 1 C 45	C 53		
	IS (INDIA)		15C8		35C8		40C8		45C8				40C10S18	40C15S12
	KS (REP. OF KOREA)				SM 35C	SM 35C			SM 45C; S 48C	SM 25C	SM 45C	SM 50C; SB 450M		
	GB/YB/JB/SY/NB (PRC)				35	35Mn	40Mn	40Mn	45	25	45	50Mn		Y40Mn

Material Designation in Accordance with Selected Standards

Standards		Material Group No.													
		2	2	2	2	2	2	2	2	2	2	2	2	2	2
	NF/AFNOR (FRANCE)	E 36-3		A 52 CP	20-400 M	A 52 FP	XC 50; 2 C 50	20 M 5	XC35RR; XC32; XC 35; XC 38 H 2; XC 38 H 1; 2 C 35	XC 38 H 1 u; Cm 35	XC 32	C50		1 C 25	
	AISI/ASM/ ASTM/SAE/ UNS/AA (US)	K12000		K02700; K02803; K03103; K03300; K12437		K12447	1049; 1050; G10490; G10500	1330; 1527; G13300; G15270	1034; 1035; 1038; G10340; G10350; G10380; C 1034		1030; G10300	1049; 1050; G10490; G10500	1536; G15360	1025; G10250	
	BS (UK)	50 C					080 M 50	150 M 19; En 14 A; En 14 B	080 M 30; En 5; 080 M 36	080 A 35	080 M 30; En 5	En 43 A; 080 M 50		070 M 26	210 A 15; 210 M 15
	DIN (GERMANY)	S355J0; St 52-3 U; Fe 510-C	S355JRC	P355GH; 19 Mn 6	C18D; GS-38	S355J2; S355J2G4; Fe 510 D2	C50E; Ck 50	28Mn6	C35E; Ck 35	C35R; Cm 35	C30E; Ck 30	C50	34Mn5	C25	15S22; 15 S 20
	Werkstoff (GERMANY)	1.0553	1.0551	1.0473	1.0416	1.0577	1.1206	1.1170	1.1181	1.1180	1.1178	1.0540	1.1166	1.0406	1.0723
	EN (EUROPE)	S355J0	S355JRC	P355GH	C18D		C50E	28Mn6	C35E	C35R	C30E	C50			
	GOST (RUSSIA)						50	30G	35						
	JIS (JAPAN)	SCC 3		SGV 410; SGV 450; SGV 480				SCMn 1	S 35 C; S 35 CM; S 38 C		S 30 C; S 30 CM	S 50 C	SMn 433 H; SMn 433 HRCH; SMn 433 RCH; SMn 1 H		SUM 32
	SS (SWEDEN)			2101; 2102	1306	2107	1674		1572			1674			1922
	UNE (SPAIN)	AE 355 C		A 52 RC I, RA II		A 52 RB II; AE 355 D			F.1130; C 35 k	F.1135; C 35 k-1	2 C 30	1 C 50	TO.B		F.210F; F.210.F
	UNI (ITALY)	Fe 510 C FN		Fe E 355-2			C 50	C 28 Mn	C 35	C 35	C 30	C 50		C 25; 1 C 25	
	IS (INDIA)	Fe570HT						27C15	35C8		30C8	50C4	37C15	25C4	
	KS (REP. OF KOREA)			SGV 410; SGV 450; SGV 480				SCMn 1	SM 35C; SGV 480			SM 50C	SMn 433H		SUM 32
	GB/YB/JB/ SY/NB (PRC)	Q345C			ZG15	Q345D	50Mn	30Mn2	35		30Mn	50Mn	30Mn2	25	Y20



Material Designation in Accordance with Selected Standards

		Material Group No.												
Standards		2	2	2	3	3	3	3	3	3	3	3	3	
	NF/AFNOR (FRANCE)				3 C 45; XC 42 H 1; XC 48 H 1 u	2 C 40; XC 42 H 1	XC 75	XC 90	XC 80		A 48 CP; A 48 AP	C 45; AF 65; C 45; 1 C 45	40 M 5; 35 Mn 5	C45RR; XC 45; XC 48 H 1
	AISI/ASM/ ASTM/SAE/ UNS/AA (US)		K03504; A105; SA-105		1045; 1049; G10450; G10490	1040; G10400	1074; 1075; G10740; G10750	1095; G10950	1086; G10860		K01700; K02001; K02200; K02201; A 516 Gr.70; A 515 Gr. 70; A 414 Gr.F; A 414 Gr.G	1043; 1045; G10430; G10450	1335; 1335 H; 1541; 1541 H; G13350; G15410; H13350; H15410	1045; 1045 H; 1042; G10450; H10450; G10420
	BS (UK)				080 M 46	080 M 40; En 8		95 HS; 95 CS	80 HS; 80 CS	A 5; A 6	224-469 B	080 M 46	150 M 36	089 H 46; 080 M 46
	DIN (GERMANY)	C45U; C45W; C 45 U; C 45 U	A105; C21; P250GH; C22.8; C22 G2	C53E; C 53 E; Ck 53	C45R; Cm 45	C40E; Ck 40	C76D; C 76 D; D 75-2	C92D; C 92 D; D 95-2	C86D; C 86 D; D 85-2	G28Mn6; GS-30 Mn 5	P295GH; 17Mn4; 17 Mn 4	C45; C 45	36Mn5; 36 Mn 5	C45E; Ck 45
	Werkstoff (GERMANY)	1.1730	1.9443; 1.0432; 1.0460	1.1210	1.1201	1.1186	1.0614	1.0618	1.0616	1.1165	1.0481	1.0503	1.1167	1.1191
	EN (EUROPE)	C45U	P250GH		C45R	C40E	C76D	C92D	C86D	G28Mn6	P295GH	C45	36Mn5	C45E
	GOST (RUSSIA)				45	40	75			27ChGSNMDTL; 30GSL	14G2		35G2; 35GL	45
	JIS (JAPAN)			S 53 C	S 45 C; S 45 CM	S 40 C				SCMn 2	SG 365; SGV 410; SGV 450; SGV 480; SPV 315; SG 37; SGV 42; SGV 46; SGV 49; SPV 32	S 45 C; S 45 CM	SMn 438; SMn 438H; SCMn 3	S 45 C; S 45 CM; S 48 C
	SS (SWEDEN)				1660						2102	1650	2120	1672
	UNE (SPAIN)				F.1145; F.1147; C 45 k-1; C 48 k-1					30 Mn 5; AM 30 Mn 5; F.120.D; F.8211; F.8311	A 47 RC I; RA II	F.114	F. 1203-36 Mn 6; F. 8212-36 Mn 5	F.1140; F.1142; C 45 k; C 48 k
	UNI (ITALY)				C 45	C 40	3 CD 75	3 CD 95	C 85; 3 CD 85		Fe 295	C 45; 1 C 45		C 45
	IS (INDIA)			55C4; C55	45C8								37C15	45C8
	KS (REP. OF KOREA)				SM 45C	SM 40C				SCMn 2	SPPV 32; SGV 49; SGV 46; SGV 42; SGV 410; SGV 450; SGV 48; SPV 450; SPV 480	SM 45C	SMn 438H; SCMn 3	SM 45C; S 48C
	GB/YB/JB/ SY/NB (PRC)				45	40Mn	75	1A95		20Mn2	16Mn	45	35Mn2	45

Material Designation in Accordance with Selected Standards

Standards		Material Group No.												
		3	3	4	4	4	4	4	4	4	4	4	4	
	NF/AFNOR (FRANCE)		44SMn28; 45 MF 6.3	P355GH	C54; 1 C 55; AF 70; C 55	C50RR; XC 54; XC 50; 2 C 55; XC 55 H 1	C60; 1 C 60	C68RR; XC 68	C75RR; XC 75	C100RR; XC 100	Y2 120; C120E3U	C90RR; XC 90	3 C 55; XC 55 H 1	C 75
	AISI/ASM/ ASTM/SAE/ UNS/AA (US)		1144; G11440	K11852; K12437; AH36; DH36; EH36	1055; G10550	1055; G10550	1060; G10600	1070; G10700	1074; 1075; 1078; G10700; G10750; G10780	1095; G10950	W112; W1; T72301	1086; G10860	1055; G10550	1074; 1075; G10740; G10750
	BS (UK)		44SMn28; 226 M 44		070 M 55; En 9	070 M 55; En 9	060 A 62; En 43 D	060 A 67; 080 A 67; En 43 E	060 A 78; 80	95			070 M 55; En 9	060 A 78
	DIN (GERMANY)	38MnVS6; 38 MnVS 6	44SMn28	GL-A 36; GL-AH 36; S 355 G 1 S	C55	C55E; Ck 55	C60	C67S; Ck 67	C75S; Ck 75	C100S; Ck 101	C125U; C 125 W	C80S; Ck 85; C 85 E	C55R; Cm 55	C75
	Werkstoff (GERMANY)	1.1303	1.0762	1.0583	1.0535	1.1203	1.0601	1.1231	1.1248	1.1274	1.1563	1.1269	1.1209	1.0605
	EN (EUROPE)	38MnVS6	44SMn28		C55	C55E	C60; 43D	C67S	C75S	C100S	C125U	C80S	C55R	
	GOST (RUSSIA)		A40G	A36	55	55	60; 60G	65GA; 68GA	75A		U12-1	85A		75
	JIS (JAPAN)		SUM 43	SPV 36	S 55 C; S 55 C-CSP; S 55 CM	S 55 C; S 55 C-CSP; S 55 CM	S 58 C; S 60-C-CSP; S 60 CM; S 65 C-CSP; S 65 CM	S 70 C-CSP; S 70 CM	S 75 CM	SK 95 -CSP	SK 120; SK 120 M; SK 2; SK 2 M; TC 120	SK 85-CP		
	SS (SWEDEN)				1655	1655		1770	1774	1870				
	UNE (SPAIN)				F.115	F.1150; C 55 K					F.5123; C 120		F.1155; C 55 k-1	
	UNI (ITALY)		CF 44 SMn 28		C 55; 1 C 55	C 55	C 60; 1 C 60	C 67	C 75	C 100	C 120 KU	C 85	C 55	C 75
	IS (INDIA)				55C4		60C4		80C6			85C6		75C6
	KS (REP. OF KOREA)		SUM 43		SM 55C	SM 55C	SM 58C							
	GB/YB/JB/ SY/NB (PRC)		Y40Mn		55	55	60	65	75	1A95	T12	T8A	55	75













Material Designation in Accordance with Selected Standards

Standards		Material Group No.												
		4	4	5	5	5	5	6	6	6	6	6	6	
	NF/AFNOR (FRANCE)	C68; XC 65		C 56 D 2	C90RR; XC 90; XC90; C90E2U	C60RR; XC 60; X 65; 2 C 60	C50RR; XC 54; XC 50; XC 55 H 1; 2 C 55	60 S 7	60 S 7	55 S 7	50S7; 51 Si 7	45 S 7; Y 46 S 7; 46 Si 7	100C2	12 CD 9-10; 10 CD 9.10
	AISI/ASM/ ASTM/SAE/ UNS/AA (US)	1070; G10700		1055; G10550		1060; 1064; G10600; G10640	1055; G10550	9260; G92600	9260 H; H92600; 9260; G92600	9255; G92550	9255; G22550		G50986; ASTM Grade E50100; ASTM Grade G15116; SAE E50100	K21390; K21590; ASTM A182 F22; ASTM A387 Grade 22; A387-22-2
	BS (UK)	060 A 67; 080 A 67; En 43 E; 1449 70 HS			CS95	060 A 62; 070 M 60; En 43 D	070 M 55; En 9		251 A 60; 251 H 60	251 A 58; En 45 A			GCr6; B00040; GCr4	622; 622-490; 622/515; 622/690
	DIN (GERMANY)	C67	C56E2; Cf 54	C56D2; C 56 D 2	C90S; C 90 S	C60E; Ck 60	C55E; Ck 55	65Si7; 65 Si 7	60Si7	56Si7; 56 Si 7; 55Si7; 55 Si 7	51Si7; 51 S 7	46Si7	100Cr2; 100 Cr 2	10CrMo9-10; 10 CrMo 9 10
	Werkstoff (GERMANY)	1.0603	1.1219	1.1220	1.1217	1.1221	1.1203	1.5028	1.5027	1.5026	1.5025	1.5024	1.3501	1.7380
	EN (EUROPE)	C67	C56E2	C56D2	C90S	C60E	C55E			56Si7; 55Si7	51Si7	46Si7		10CrMo9-10
	GOST (RUSSIA)					60GA	55	60S2G	60S2	55S2; 60S2			SchCh4	12Ch8
	JIS (JAPAN)	S 70 C-CSP; S 70 CM	C56E2; S55C		SK 95	S 58 C; S 60 C-CSP; S 60 CM; C 65 C-CSP; C 60 CM	S 55 C; S 55 C-CSP; S 55 CM	50 P 7; SUP 6; SUP 6 M; SUP 7; SWOSM						SCMQ4E; SCMV 4; SFVA F 22.A; SFVA F 22.B; SFVCM F22B; STBA 24; STFA 24; STPA 24
	SS (SWEDEN)					1678	1655				2085; 2090			2218
	UNE (SPAIN)						F.1150; C 55 k		F.144.B; F.1441	F.144; F.144.A; 56 Si 7; F.1440	F.145.B	F.1451		TJ.H
	UNI (ITALY)	C 67				C 60	C 55		60 Si 7	55 Si 7	48 Si 7; 50 Si 7			12 CrMo 9 10
	IS (INDIA)	65C6					55C4	65Si7	60Si7	55Si7				
	KS (REP. OF KOREA)		S 55C			SM 58C	SM 55C	SPS 6						SPA 24
	GB/YB/JB/ SY/NB (PRC)	70		55		60Mn	55	60Si2Mn	60Si2Mn	55Si2Mn	55Si2Mn		GCr6	12Cr2Mo1





Material Designation in Accordance with Selected Standards

Standards		Material Group No.											
		6	6	6	6	6	6	6	6	6	6	6	
	NF/AFNOR (FRANCE)	90 MnV 8; 90 MV 8	55 WC 20		100 C 3	105 WCr 5; 105 WC 13	20 MC 5	55 S 7	55 S 7	60 SC 6	34 CD 4; 34CrMo4RR; 35 CD 4;		100Cr6RR; 100 C 6; 100Cr6; Y 100 C 6
	AISI/ASM/ ASTM/SAE/ UNS/AA (US)	O2; T31502			L2; T61202		4820; 5120; 5120H; G48200; G51200; H51200	9255; G92550	9254; G92550	9262; G95620	4135; 4137; 4135H; 4137H; G41350; G41370; H41350; H41370		L3; T61203
	BS (UK)	BO 2; BO2	BS1; BS 1			105WC 13	150 M 19	250A53	250 A 53		708 A 30		BL 3; BL3
	DIN (GERMANY)	90MnCrV8; 90 MnCrV 8	60WCrV7; 60 WCrV 7	51CrMnV4; 51 CrV 4; 50 CrV 4	115CrV3; 115 CrV 3	105WCr6; 105 WCr 6	20MnCr5; 20 MnCr 5	55Si7; 55 Si 7	55Si7; 55 Si 7	HDT 450 F; S340 MGC	34CrMo4; GS34 CrMo 4; G34 CrMo 4	38MnSi4; 38 MnSi 4	102Cr6; 102 Cr 6; 100Cr6
	Werkstoff (GERMANY)	1.2842	1.2550	1.2241	1.2210	1.2419	1.7147	1.0904	1.0904	1.0961	1.7220	1.5120	1.2067
	EN (EUROPE)	90MnCrV8	60WCrV7		115CrV3	105WCr6	20MnCr5				34CrMo4		102Cr6
	GOST (RUSSIA)					ChW1G; ChWG	18ChG			60S2; 55S2; 50ChFA	35ChM; AS38ChGM		Ch
	JIS (JAPAN)					SKS 2; SKS 2 M; SKS 3; SKS 31	SMnC 420 H; SMnC 420 RCH; SMnC 21 H				SCM 435 H; SCM 435 HRCH; SCM 435 M; SCM 435 RCH; SCM 435TK; SCM 3 H; STKS 3		SUJ 2
	SS (SWEDEN)		2710			2140	2172	2085	2090		2234		
	UNE (SPAIN)	90 MnCrV 8; F.5229	60 WCrSiV 8; F.5242		F.520.L; F.5125	F.5233; 105 WCr 5	F.150.D	56 Si 7		60 SiCr 8; F.1442	35 CrMo 4 DF; F.125.A; F.125.B; F.1254; F.1250		F.5230; 100 Cr 6
	UNI (ITALY)	90 MnVCr 8 KU	55 WCrV 8 KU; 58 WCr 9 KU		107 CrV 3 KU	107 WCr 5 KU	20 MnCr 5; Fe52	55 Si 8		60 SiCr 8	34 CrMo 4 KB; 35 CrMo 4		102 Cr 6 KU
	IS (INDIA)					T110W2Cr1	20MnCr1	55Si2Mn90					
	KS (REP. OF KOREA)					STS 31					SCM 435 TK		STB 2
	GB/YB/JB/ SY/NB (PRC)	9Mn2V				9CrWMo	15CrMn	55Si2Mn	55Si2Mn		35CrMo	42SiMn	Cr2

Material Designation in Accordance with Selected Standards

Standards		Material Group No.											
		6	6	6	6	6	6	6	6	6	6	6	6
	NF/AFNOR (FRANCE)		34 CD 4	90MnWCrV5; 90 MWCV 5; 8 MO 8	45 WCrV 8; 45 WCrV 20	55 NCDV 7	55 NCV 6	100Cr6RR; 100 C 6; 100Cr6	15 D 3		16 N 6	14 NC 11	10 NC 12; 12 NC 15; 14 NC 12; 16 NC 12; 16 NCD 13
	AISI/ASM/ ASTM/SAE/ UNS/AA (US)	L1	P20; T51620	O1; T31501	S1; T41901	L6; T61206		E52100; G52986	K11820; K12020; K12320; A204 Grade A; A182 Grade F1	4422; G44220; J12522	A 350-LF 5; K13050; K21703; K22103	3415	3310; 3310 RH; 3312; 3316; 9315; E 3310; E 3316; E9315; G33106
	BS (UK)		708 A 37	B01; B00; BO 1; BO 0	BS1; BS 1	BH 224; BH 225		2 S.135; 535 A 99	1503-243 B	245; B 1; B1			655 M 13; 655 H 13; En 36 A
	DIN (GERMANY)	90CrSi5; 90 CrSi 5	35CrMo4; 35 CrMo 4	100MnCrW4; 100 MnCrW 4	45WCrV7; 45 WCrV 7	55NiCrMoV6; 56NiCrMoV6; 55 NiCrMoV 6; 56 NiCrMoV 6	50NiCr13	100Cr6; 100 Cr 6	16Mo3; 15 Mo 3	G20Mo5; 20Mo4; GS-22 Mo 4	14Ni6; 14 Ni 6	14NiCr10; 14 NiCr 10	15NiCr13; 14NiCr14; 15 NiCr 13; 14NiCr14
	Werkstoff (GERMANY)	1.2108	1.2330	1.2510	1.2542	1.2713	1.2721	1.3505	1.5415	1.5419	1.5622	1.5732	1.5752
	EN (EUROPE)	90CrSi5	35CrMo4	100MnCrW4	45WCrV7	55NiCrMoV6		100Cr6		G20Mo5	14Ni6	14NiCr10	15NiCr13
	GOST (RUSSIA)				5ChW25F	5ChNM		SchCh 15				12ChN3A	
	JIS (JAPAN)			SKS 31		SKT 4		SUJ 2; SUJ 4	STBA 12; STFA 12; STPA 12	SCPH 11		SNC 415; SNC 415 H; SNC 415 M	SNC 815 H; SNC 815 HRCH; SNC 815 RCH; SNC 22 H
	SS (SWEDEN)	2092	2234	2140	2710		2550	2258	2912; 16Mo3				
	UNE (SPAIN)			F.522.A; F.5220; 95 MnCrW5; 105 WCr 5	F.524; F.5241; 45 WCrSi 8	F.520.S	F.528	F.131; 100 Cr 6; F.1310	F. 2601; 16 Mo 3		F.2641; 15 Ni 6	15 NiCr 11	15 NiCr 11; F.1540
	UNI (ITALY)	105 WCr 5	35 CrMo 4	95 MnWCr 5 KU; 10 WCr 6	45 WCrV 8 KU			100 Cr 6	16 Mo 3 KG; 16 Mo 3 KW; 16 Mo 5 KG; 16 Mo 5 KW		14 Ni 6 KG; 14 Ni 6 KT	16 NiCr 11	
	IS (INDIA)							105Cr1Mn60					13Ni3Cr80
	KS (REP. OF KOREA)		SCM 435 TK	STS 31		STF 4		STB 2	SPA 10	SCPH 11			
	GB/YB/JB/ SY/NB (PRC)	9SiCr	3CrMo	CrWMn	5CrW2Si	5CrNiMo		Gr15; 45G	16Mo			12CrNi2	12CrNi3A

Material Designation in Accordance with Selected Standards

Standards		Material Group No.										
		6	6	6	6	6	6	6	6	6	6	
	NF/AFNOR (FRANCE)	12 CD 4	18 NCD 6	16 NCD 13	12 C 3; 15Cr2RR; 15 C 2	32 C 4	42 C 4	42 C 4 TS	16MnCr5RR; 16 MC 5	16MnCrS5	55 C 3; 55Cr3	MOC 2; V320
	AISI/ASM/ ASTM/SAE/ UNS/AA (US)			9310; 9310H; 9310 RH; E 9310 H; G93106; H93100; H93106; AMS 6265	5015; G50150	5132; 5132 H; G51320; H51320	5140; 5140 H; 5140 RH; G51400; H51400	5140; G51400	5115; 5117; G51150; G51170		5155; 5155 H; 5150; G51550; H51550; G51600	4142; G41420
	BS (UK)		820A16	832 H 13; 832 M 13; S.157; En 36 C	523 M 15	530 A 32; 530 H 32; 530 M 32	530 A 40; 530 M 40; 530 H 40; En 18	530 A 40	527 M 17; 590 H 17; 590 M 17		525 A 58; 525 A 60; En 48	
	DIN (GERMANY)	15CrMo5; 15 CrMo 5	17CrNiMo6; 17 CrNiMo 6	14NiCrMo13-4; 14 NiCrMo 13 4	15Cr3; 15 Cr 3	34Cr4; 34 Cr 4	41Cr4; 41 Cr 4	42Cr4; 42 Cr 4	16MnCr5; 16 MnCr 5	16MnCrS5; 16 MnCrS 5	55Cr3; 55 Cr 3	41CrMo4; 41 CrMo 4
	Werkstoff (GERMANY)	1.7262	1.6587	1.6657	1.7015	1.7033	1.7035	1.7045	1.7131	1.7139	1.7176	1.7223
	EN (EUROPE)	15CrMo5			15Cr3	34Cr4	41Cr4		16MnCrS5	16MnCrS5	55Cr3	
	GOST (RUSSIA)				15Ch	35Ch	40Ch		18ChG		50ChGA	40ChFA
	JIS (JAPAN)	SCM 415 H; SCM 415 HRCH; SCM 415 M; SCM 415 RCH; SCM 415 TK; SCM 21 H			SCr 415; SCr 415 H; SCr 415 HRCH; SCr 415 RCH; SCr 21 H	SCr 430; SCr 430 H; SCr 430 HRCH; SCr 430 RCH; SCr 2 H	SCr 440; SCr 440 H	SCr 440			SUP 9; SUP 9 A; SUP 9 M	SNB 22-1
	SS (SWEDEN)							2245	2173	2127	2253	
	UNE (SPAIN)	12 CrMo 4; F.150.J; F.155; F.1551	14 NiCrMo 13	14 NiCrMo 13; 14 NiCrMo 13-1; F.1560; F.1569		35 Cr 4; F.8221	41 Cr 4 DF; F.1211; F.1202	42 Cr 4	F.1516		F.1431	42 CrMo 4
	UNI (ITALY)			15 NiCrMo 13; 16 NiCrMo 12		34 Cr 4; 34 Cr KB	41 Cr 4; 41 Cr 4 KB	41 Cr 4	16 MnCr 5		55 Cr 3	41 CrMo 4
	IS (INDIA)		15Ni2Cr1Mo15		15Cr3		40Cr1		17Mn1Cr95		55Cr3	
	KS (REP. OF KOREA)					SCr 430; SCr 430H	SCr 440	SCr 440			SPS 9A	SNB 22-1
	GB/YB/JB/ SY/NB (PRC)	15CrMnMo			15Cr	35Cr	40Cr	40Cr	15Cr		50CrMn	40CrMoA







Material Designation in Accordance with Selected Standards

Standards		Material Group No.									
		6	6	6	6	6	6	6	6	6	6
	NF/AFNOR (FRANCE)	42 CD 4; 40 CD 4; 42CrMo4RR			15 CD 4-05	12 CD 9-10; 10 CD 9.10		40 CAD 6.12		40 CMD 8 S	
	AISI/ASM/ASTM/SAE/UNS/AA (US)	4140; 4140 H; 4140 RH; 4142; 4142 H; 4145; G41400; H41400; G41420; H41420; K14248; K14047	4147; 4147 H; 4150; 4150 H; 8650; 8650 H; G41470; G41500; G86500; H41470; H41500; H86500	4118; 4118H; G41180; H41180	K11547; K11562; K11564; K11757; K11789; K12052; ASTM A182 F12	K21390; K21590; ASTM A182 F22		E71400; K24065; K24728; A355 Class A		P20+S	
	BS (UK)	708 M 40; 709 M 40; En 19; En 19 A	708 M 40; 708 A 47		620; 620-440; 620-470; 620-540; 621	622; 622-490; 622/515; 622/690; 1502-622	1503-660-440	905 M 39; En 41 B			
	DIN (GERMANY)	42CrMo4; 42CrMo4V; 42 CrMo 4; 42 CrMo 4 V	50CrMo4; 50 CrMo 4	20MoCr4; 20 MoCr 4	13CrMo4-5; 13 CrMo4 4	10CrMo9-10; 10 CrMo 9 10; GS-12CrMo9-10; GS-12 CrMo 9 10; G 12 CrMo9-12	14MoV6-3; 14 MoV 6 3	41CrAlMo7-10; 41CrAlMo7; 41 CrAlMo 7	17NiCrMo6-4	40CrMnMoS8-6	20MnCrS5; 20 MnCrS 5
	Werkstoff (GERMANY)	1.7225; 1.7227	1.7228	1.7321	1.7335	1.7380	1.7715	1.8509	1.6566	1.2312	1.7149
	EN (EUROPE)	42CrMo4	50CrMo4	20MoCr4	13CrMo4-5	10CrMo9-10		41B	17NiCrMo6-4		20MnCrS5
	GOST (RUSSIA)	40ChFA		BGH 7321; E320; SIQUAL 7321	12ChM; 15ChM	12Ch8		38Ch2MJuA			
	JIS (JAPAN)	SCM 440 H; SCM 440 HRCH; SCM 440 M; SCM 440 RCH; SCM 440 TK; SNB 7 Class 2; SCM 4 H; SNB 22-1	SCM 445 H; SCM 445 HRCH; SCM 445 RCH; SCM 5 H		SCMV 2; SFVA 12; STBA 22; STFA 22; STPA 20; STPA 22	SCMQ 4 E; SCMV 4; SFVA F 22 A; SFVA F 22 B; SFVCM F 22 B; STBA 24; STFA 24; STPA 24		SACM 645; SACM 1			
	SS (SWEDEN)	2244; 42CrMo4	2512	2625	2216	2218		2940			
	UNE (SPAIN)	T.O.D; T.U.L			T.U.E; T.U.F; F.2631; 14 CrMo 4 5	T.U.H	13 MoCrV 6	F.174; 41 CrAlMo 7; F1740			
	UNI (ITALY)	42 CrMo 4; 38 CrMo 4 KB; 41 CrMo 4	653 M 31		14 CrMo 3; 14CrMo4 5	12 CrMo 9; 12 CrMo 10		41 CrAlMo 7			
	IS (INDIA)	40Cr4Mo3						40Cr2Al1Mo18			
	KS (REP. OF KOREA)	SNB 22-1			SPA 22	SPA 24					
	GB/YB/JB/SY/NB (PRC)	42CrMo; 42CrMnMo		20CrMo	12CrMo	12Cr2Mo1		38CrMoAl			















Material Designation in Accordance with Selected Standards

Standards		Material Group No.												
		6	6	6	6	6	6	6	6	6	6			
	NF/AFNOR (FRANCE)	40 CMND 8	40 CMD 8		51 CDV 4; 51CrMoV4			15 CD 3.5						
	AISI/ASM/ ASTM/SAE/ UNS/AA (US)	P20+Ni			4150; G41500					4419; 4419 H; 4520; G44190; H44190; G45200; K11522; K11820; K12020; K12023; K12320; K12821			HY-80; HY 80; HY80; K31820; MIL-S-21952	
	BS (UK)													605 M 36; En 16; En 16T
	DIN (GERMANY)	40CrMnNiMo8-6-4; 40 CrMnNiMo 8 6 4	40CrMnMo7; 40 CrMnMo 7	49CrMo4; 49 CrMo 4	52CrMoV4; 51CrMoV4; 51 CrMoV 4	16CrMo4-4; 16 CrMo 4 4	16CrMo4; 16 CrMo 4	16Mo5						
	Werkstoff (GERMANY)	1.2738	1.2311	1.7238	1.7701	1.7337	1.7242	1.5423						
	EN (EUROPE)	40CrMnNiMo8-6-4	40CrMnMo7		51CrMoV4		16CrMo4							
	GOST (RUSSIA)	40Ch2GNM								30ChGSA				
	JIS (JAPAN)					SCM 415 M; SCM 415; STBA 22; SFVA F12	SCM 418 H; SCM 418 HRCH; SCM 418 RCH; SCM 418 TK	SB 450 M; SB 480 M; SB 46 M SB 49 M						
	SS (SWEDEN)													
	UNE (SPAIN)		F.5302				F.1550; 18 CrMo 4	TU.D; F.2602						
	UNI (ITALY)		35 CrMo 8 KU		51 CrMoV 4	A 18 CrMo 45 KW	18 CrMo 4	16 Mo 5 KG; 16 Mo 5 KW						
	IS (INDIA)													
	KS (REP. OF KOREA)							SB 450M						
	GB/YB/JB/ SY/NB (PRC)		5CrMnMo			15CrMo		15Mn						













Material Designation in Accordance with Selected Standards

Standards		Material Group No.											
		6	6	6	6	6	6	6	6	6	6	6	6
	NF/AFNOR (FRANCE)		16 NC 6		35 C 2; 38 C 2						E 690 D		38 B 3; 38B3
	AISI/ASM/ ASTM/SAE/ UNS/AA (US)	K52440	4320; 4320H; G43200; H43200		5140; G51400	E51100; E52100; G51986; G52986		P6; T51606			A514 Grade B; K11630	A709-100; A709 Grade 100	
	BS (UK)		815 M 17		120 M 36						75 F 70		
	DIN (GERMANY)	34CrAlNi7-10; 34CrAlNi7; 34 CrAlNi 7	15 CrNi 6	17CrNi6-6	38Cr2; 38 Cr 2	105Cr4; 105 Cr 4	140Cr2; 140 Cr 3	15NiCr14; 15 NiCr 14	S690QL1; ESiE 690V	26CrMo4-2; 26 CrMo 4	S700MC; QSiE 690 TM	S690QL; TSiE 690 V	20MnB4; 20 MnB 4
	Werkstoff (GERMANY)	1.8550; 1.2891	1.5919	1.5918	1.7003	1.2057	1.2008	1.2735	1.8988	1.7219	1.8974	1.8928	1.5525
	EN (EUROPE)	34CrAlNi7-10		17CrNi6-6	38Cr2				S690QL1	26CrMo4-2	S700MC	S690QL	20MnB4
	GOST (RUSSIA)		12ChN2				13Ch						
	JIS (JAPAN)		SNCM 415			SUJ 1							
	SS (SWEDEN)		2511; 2512									2625	
	UNE (SPAIN)				F.1200	F.120.J							
	UNI (ITALY)	34 CrAlNi 7			41 Cr 2 KB								
	IS (INDIA)		15NiCr1Mo12		40Cr1	105Cr1							
	KS (REP. OF KOREA)												
	GB/YB/JB/ SY/NB (PRC)				40Cr	GC9	Cr06						

Material Designation in Accordance with Selected Standards

Standards		Material Group No.										
		6	6	6	6	6	7	7	7	7		
	NF/AFNOR (FRANCE)	P460NL1; A 590 FP				18 NCD 6		25 CD 4				20 CDV 6
	AISI/ASM/ASTM/SAE/UNS/AA (US)	K12202	A217 WC6; A372 Grade J; J12072; J12073; K11598	ASTM A387 Grade 11 Class 2; A 387 Grade 11 Class 2; SA387 GR 11 CLASS 2; SA387 Gr.11 CL2; SA387-11-2; K11789			5120; G51200	4130; 4130 H; 4130 RH; G41300; H41300				
	BS (UK)			621 A; 621 B				708 A 25				
	DIN (GERMANY)	P460NL1; P460 NL1; TS/E 460	G17CrMo5-5; GS-17 CrMo 5 5	13CrMoSi5-5	18CrNiMo7-6; 17CrNiMo6; 17 CrNiMo 6	20Cr4; 20 Cr 4	25CrMo4; 25 CrMo 4; GS-25 CrMo 4; G 25 CrMo 4	21CrMoV5-11; 21 CrMoV 5 11	GS-35 CrMoV 10 4; G35 CrMoV 10-4			24CrMoV5-5
	Werkstoff (GERMANY)	1.8915	1.7357	1.7336	1.6587	1.7027	1.7218	1.8070	1.7755			1.7733
	EN (EUROPE)	P460NL1; P460 NL1	G17CrMo5-5	13CrMoSi5-5	18CrNiMo7-6	20Cr4	25CrMo4					
	GOST (RUSSIA)					20Ch	20ChM; 30ChM					
	JIS (JAPAN)	SHY 685 N; SHY 685 NS	SCPH 21			SCr 420	SCM 420 TK; SCM 430 M; SCM 430 RCH; SCM 430 TK; STKS 1					
	SS (SWEDEN)						2225					
	UNE (SPAIN)	P460NL1			F.1560; 14 NiCrMo 13		F.222; F.1256					
	UNI (ITALY)				18 NiCrMo 7		25 CrMo 4; 25 CrMo KB	35 NiCr 9				21 CrMoV 5 11
	IS (INDIA)											
	KS (REP. OF KOREA)					SCr 420	SCM 420; SCM 430					
	GB/YB/JB/SY/NB (PRC)					20Cr; A20202	30CrMo					12Cr1MoV

Material Designation in Accordance with Selected Standards

		Material Group No.										
Standards		7	7	7	7	7	7	7	7	7	7	
	NF/AFNOR (FRANCE)		40 NCD 2; 40 NCD TS	20 NCD 2	18 NC 13	35 NC 6	34 CrNiMo 8; 35 NCD 6		30 NCD 2	30 CND 8; 30 NCD 8	20MV6; TS E 455 4; TU E 455 4	
	AISI/ASM/ ASTM/SAE/ UNS/AA (US)	4340; 4340 H; 9850; G43400; G98500; H43400; K23028	8640; 8640 H; 8740; 8740 H; 8742; G86400; G87400; G87420; H86400; H87400; K11640	8617; 8617 H; 8620; 8620 H; 8620 RH; 8617; G86170; G86200; H86170; H86200; K12147		3135	4340; G43400; 4337; G43370		8630	4340; G43400	K01907	300M; 4340M; K44220
	BS (UK)	817 M 40; En 24		805 H 20; 805 M 20; 806 M 20; En 362	653 M 31	640 A 35	816 M 6; 817 M 40			823 M 30	55 C; GR 55; Grade 55	S 155
	DIN (GERMANY)	40NiCrMo6; 40 NiCrMo 6	40NiCrMo2-2; 40 NiCrMo 2 2	20NiCrMo2-2; 21NiCrMo2; 21 NiCrMo 2	31NiCr14; 31 NiCr 14	36NiCr6; 36 NiCr 6	34CrNiMo6; 34 CrNiMo 6	31CrMoV9; 31 CrMoV 9	30NiCrMo2-2; 30 NiCrMo 2 2	30CrNiMo8	20MnV6; 20MnVS6; 20 MnV 6 N	41SiNiCrMoV7-6
	Werkstoff (GERMANY)	1.6565		1.6523	1.5755	1.5710	1.6582	1.8519	1.6545	1.6580	1.5217	1.6928
	EN (EUROPE)	40NiCrMo6		20NiCrMo2-2		36NiCr6	34CrNiMo6	31CrMoV9			20MnV6; S460	
	GOST (RUSSIA)	40Ch2N2MA	38ChGNM	20ChGNM			38Ch2N2MA	30Ch3MF				
	JIS (JAPAN)	SNB 24-1; SNB 24-2; SNB 24-3; SNB 24-4; SNB 24-5; SNCM 439 RCH	SNCM 240; SNCM 240 RCH	SNCM 220; SNCM 220 H; SNCM 220 HRCH; SNCM 220 M; SNCM 220 RCH; SNCM 21 H		SNC 236				SNCM 431		
	SS (SWEDEN)			2506			2541					
	UNE (SPAIN)	F.1275; 40 NiCrMo 7	40 NiCrMo 2 DF; F.1205; F.1204; TO.E	20 NiCrMo 2; 20 NiCrMo 3-1; F.1522; F.1534			F.1272			30 CrNi Mo 8		
	UNI (ITALY)		40 NiCrMo 2; 40 NiCrMo 2 KB	20 NiCrMo 2			35 NiCrMo 6 KB		30 NiCrMo 2 KB			
	IS (INDIA)	40Ni2Cr1Mo28		20NiCrMo2								
	KS (REP. OF KOREA)	SNB 24-1; SNB 24-2; SNB 24-3; SNB 24-4; SNB 24-5	SNCM 240	SNCM 220; SNCM 220H		SNC 236						
	GB/YB/JB/ SY/NB (PRC)	40CrNiMoA		21NiCrMo2	30CrNi3A	40CrNi	40CrNiMoA				20MnV	















Material Designation in Accordance with Selected Standards

Standards		Material Group No.										
		7	7	7	7	7	7	7	7	7	7	
	NF/AFNOR (FRANCE)	E690D	20 NCD 2; 20NiCrMo2					15 CDV 6; 9160/C 33; 9160 C 073				
	AISI/ASM/ ASTM/SAE/ UNS/AA (US)	A514; A514/T-1; K11630							WC5; A217 grade WC5			E4340; G43406
	BS (UK)	75 F 70									S 153; S 154	
	DIN (GERMANY)	S700MC; QSTE 690 TM	20NiCrMo2	47CrMo4; 47 CrMo 4	38MnSiVS5; 38 MnSiVS 5	20NiCrMoS2-2; 21NiCrMoS2	12CrMoV6-9; 12 CrMoV 6 9		G22NiMoCr5-6	St 145/160	32NiCrMo10-4; 32 NiCrMo 10 4	30CrMoV9; 30 CrMoV 9
	Werkstoff (GERMANY)	1.8974; 1.0966	1.6522	1.2332	1.5231	1.6526	1.7734; 1.7736		1.6760	1.8863	1.6743	1.7707
	EN (EUROPE)	S700MC	20NiCrMo2			20NiCrMoS2-2	15CrMnMoV5-4-9-3; 4334; FE-WL 1806; FE-PL 52 S	19MnV6; E470		St 145/160		30CrMoV9
	GOST (RUSSIA)										38ChN3MA	
	JIS (JAPAN)		SNM 220 H; SNM 21 H									
	SS (SWEDEN)					92506		2142				
	UNE (SPAIN)		20 NiCrMo 2; F.1527								F.127	
	UNI (ITALY)						15CrMoV6					
	IS (INDIA)											
	KS (REP. OF KOREA)											
	GB/YB/JB/ SY/NB (PRC)			42CrMo ; 42CrMnMo								















Material Designation in Accordance with Selected Standards

		Material Group No.										
Standards		8	8	8	8	8	8	8	8	8	8	8
	NF/AFNOR (FRANCE)		30 CD 12		30 CD 12	40 NCD 3; 35 NCD 5	50CrV4RR; 50 CV 4; 51 CV 4	30 NC 11	Z 120 M 12	42 CD 4		
	AISI/ASM/ ASTM/SAE/ UNS/AA (US)					9840; G98400	6145; 6150; 6150 H; G61500; H61500	3435	A128 Grade A; J91109; J91129; J91139; J91149	4142; G41420	4140 H; 4140 RH; 4140 HT	
	BS (UK)	897 M 39	722 M 24		722 M 24	817 M 37; 816 M 40	735 A 50; 735 A 51; 735 H 51; 735 M 50; En 47		BW 10	708 M 40		
	DIN (GERMANY)	40CrMoV13-9; 39CrMoV13-9; 39 CrMoV 13 9	31CrMo12; 31 CrMo 12	58CrV4; 58 CrV 4	32CrMo12; 32 CrMo 12	36CrNiMo4; 36 CrNiMo 4	51CrV4; 50CrV4; 50 CrV 4	36NiCr10; 36 NiCr 10	X120Mn12; X 120 Mn 12; G-X120 Mn 12	47CrMo4	42CrMo4+QT	21MnCr6-5
	Werkstoff (GERMANY)	1.8523	1.8515	1.8161	1.7361	1.6511	1.8159	1.5736	1.3401; 1.3403	1.2332		1.8705
	EN (EUROPE)	40CrMoV13-9	31CrMo12; 40B		32CrMo12	36CrNiMo4	51CrV4			47CrMo4		
	GOST (RUSSIA)					40ChGNM; 40ChN2MA	50ChFA; 50ChGFA		110G13L			
	JIS (JAPAN)					SUP 10	SUP 10; SUP 10-CSP; SUP 10 M	SNC 631; SNC 631 H; SNC 631 M	SCMnH 1; SCMnH 11	SCM; SCM 440		
	SS (SWEDEN)		2240		2240		2230		2183	2244		
	UNE (SPAIN)		F.1712; F.124.A		F.124.A	F.128; F.1280; 35 NiCrMo 4	F.143; F.143.A; 51 CrV 4; F.1430		F.240.A; F.240.A1; AM-X 120 Mn 12; F.8251	42 CrMo 4		
	UNI (ITALY)	36 CrMoV 12	32 CrMo 12		30 CrMo 12	39 NiCrMo 4; 39 NiCrMo 4 KB	50 CrV 4		GX 120 Mn 12	42 CrMo 4		
	IS (INDIA)						T50Cr1V23					
	KS (REP. OF KOREA)					SPS 10	SPS 10		SCMnH 1, SCMn H 11			
	GB/YB/JB/ SY/NB (PRC)					40CrNiMo	50CrVA	20CrNi3A	ZGMn13	42CrMo; 42CrMnMo	42CrMo; 42CrMnMo	

Material Designation in Accordance with Selected Standards

Standards		Material Group No.											
		8	8	8	9	9	9	9	9	9	9	9	
	NF/AFNOR (FRANCE)	45 SCV 6							42 C 2; 45 C 2				16 NCD 17
	AISI/ASM/ ASTM/SAE/ UNS/AA (US)								5045; 5046; 5150; 5150 H; G50460; G51500; H51500				
	BS (UK)				830 M 31								5 S.82; 835 H 15; 835 N 15; En 39 B
	DIN (GERMANY)	45SiCrV6; 45 SiCrV 6	S890Q	45B2	31NiCrMo13-4	35NiCr18	17MnCr5-3	46Cr2; 46 Cr 2; 45 Cr 2	62SiMnCr4; 62 SiMnCr 4	48CrMoV6-7; 48 CrMoV 6 7	65MnCrMo4; 65 MnCrMo 4	80CrV2; 80 CrV 2; 80 CrV 2 3	15NiCrMo16-5; 15 NiCrMo 16 5
	Werkstoff (GERMANY)	1.2249	1.8940	1.5513	1.6659	1.5864	1.8715	1.7006; 1.7005	1.2101	1.2323	1.2309	1.2235; 1.2236	1.6723
	EN (EUROPE)		S890Q				17MnCr5-3	46Cr2				80CrV2	
	GOST (RUSSIA)											8ChF; 9ChF	
	JIS (JAPAN)												
	SS (SWEDEN)				2534								
	UNE (SPAIN)				F.270							F.520.J	F.156
	UNI (ITALY)							45 Cr 2					
	IS (INDIA)					30Ni4Cr1							
	KS (REP. OF KOREA)												
	GB/YB/JB/ SY/NB (PRC)	4SiCrV						50Cr					















Material Designation in Accordance with Selected Standards

Standards		Material Group No.								
		9	10	10	10	10	10	10	10	10
	NF/AFNOR (FRANCE)	55 NCDV 7; 55 NiCrMoV7	9 Ni; Z 8 N 09	Z 18 N 5; Z 10 N 05; 5 Ni	Z 200 CD 12; Z 210 CW 12-01; X210CrW12-1	X 40 CrMoV 5; Z 40 CDV 5	X 100 CrMoV 5; Z 100 CDW 5	Z 30 WCV 9		
	AISI/ASM/ ASTM/SAE/ UNS/AA (US)	L6; T61206	K71340; K81340	2515; A2515; 2517; E2517; K41583	D4; T30404; D6; T30406	H13; T20813	A2; T30102	H21; T20821		
	BS (UK)		1501-509; 1501-510; 502-650; 509-690		BD6	BH 13	BA 2	BH 21		
	DIN (GERMANY)	55NiCrMoV7; 56 NiCrMoV 7	X8Ni9	X12Ni5; 12Ni19;	X210CrW12; X 210 CrW 12	X40CrMoV5-1; X40 CrMoV 5 1	X100CrMoV5; X100CrMoV5-1; X 100 CrMoV 5 1	X30WCrV9-3; X30WCrV9 3	X165CrMoV12; X 165 CrMoV 12	X36CrMo17; X38CrMo16
	Werkstoff (GERMANY)	1.2714	1.5662	1.5680	1.2436	1.2344	1.2363	1.2581	1.2601	1.2316
	EN (EUROPE)	55NiCrMoV7	X8Ni9	X12Ni5	X210CrW12	X40CrMoV5-1	X100CrMoV5	X30WCrV9-3; X30WCrV9 3	X165CrMoV12	X38CrMo16
	GOST (RUSSIA)	5ChGNM				4Ch5MF1S		3Ch2W8F		
	JIS (JAPAN)	SKT 4	SL9N520; SL9N590; STBL 690; STPL 690; SL9N53; SL9N60; STBL 70; STPL 70	SL5N590; SL5N60	SKD 2	SKD 61	SKD 12	SKD 5		
	SS (SWEDEN)				2312	2242	2260		2310	
	UNE (SPAIN)	F.520.B; 55 NiCrMoV 7; F.5307	F.2645; XBNi 09		F.5213; X210 CrW 12	F.5318; X 40 CrMoSiV 5	F.536; F.5227; X 100 CrMoV 5	F.5323; X 30 WCV 9		
	UNI (ITALY)	55 NiCrMoV 7 KU; 56 NiCrMoV 7 KU	X 10 Ni 9; X 12 Ni 09		X 215 CrW 12 1 KU	X 40 CrMoV 5 1 1 KU	X 100 CrMoV 5 1 KU	X 30 WCV 9 3 KU	X165CrMoV12KU	
	IS (INDIA)									
	KS (REP. OF KOREA)	STF 4	SL9N590; SL9N520			STD 61	STD 12	STD 5		
	GB/YB/JB/ SY/NB (PRC)	5CrNiMo				40CrMoV5	Cr5Mo1V	3Cr2W8V	Cr12MoV	

Material Designation in Accordance with Selected Standards

Standards		Material Group No.							
		10	10	10	10	10	10	10	10
	NF/AFNOR (FRANCE)	Z 85 WDCV 06-05-04-02; 6-5-2; HS6-5-2	Z 38 CDV 5; X38CrMoV	Z 35 CWDV 5; X35CrWMoV5	X 160 CrMoV 12; Z 160 CDV 12	Z 35 V CD 17.S	20 MC 5	45 NCD 16	
	AISI/ASM/ ASTM/SAE/ UNS/AA (US)	M2; T11302	H11; T20811	H12; T20812	D2; T30402				
	BS (UK)	BM 2; BM2	BH 11	BH 12	BD 2				
	DIN (GERMANY)	HS6-5-2; HS 6-5-2; S 6-5-2	X37CrMoV5-1; X38CrMoV5-1	X37CrMoW5-1; X 37 CrMoW 5 1; X35CrWMoV5; X 35 CrWMoV 5	X153CrMoV12; X155CrVMo12-1; X155 CrVMo 12 1	X33CrS16; X 33 CrS 16	21MnCr5; 21 MnCr 5	X45NiCrMo4; 45NiCrMo16; X 45 NiCrMo 4	X19NiCrMo4; X 19 NiCrMo 4; GX19NiCrMo4
	Werkstoff (GERMANY)	1.3343	1.2343	1.2606; 1.2605	1.2379	1.2085	1.2162	1.2767	1.2764
	EN (EUROPE)	HS6-5-2	X37CrMoV5-1	X37CrMoW5-1; X35CrWMoV5	X153CrMoV12	X33CrS16	21MnCr5	X45NiCrMo4	X19NiCrMo4
	GOST (RUSSIA)	R6M5	4Ch5MFS						
	JIS (JAPAN)	SKH 51	SKD 6	SKD 62	SKD 10; SKD 11				
	SS (SWEDEN)	2722			2310				
	UNE (SPAIN)	F.550.A; F.5604	F.520.G; F.5137; X 37 CrMoSiV 5	F.537	F.520.A				
	UNI (ITALY)		X 37 CrMoV 5 1 KU	X 35 CrMoW 05 KU	X 155 CrVMo 12 1 KU			40 NiCrMoV 8 KU	
	IS (INDIA)								
	KS (REP. OF KOREA)	SKH 51							
	GB/YB/JB/ SY/NB (PRC)	W6Mo5Cr4V2	4Cr5MoV5	4Cr5W2V5I	Cr12MoV				















Material Designation in Accordance with Selected Standards

Standards		Material Group No.							
		10	10	10	10	10	10	10	10
	NF/AFNOR (FRANCE)	X200Cr12; Z 200 C 12				80 DCV 40; 80MoCrV42-16			Z 120 WDCV 06-05-04-03; HS6-5-3; Z 120 WDCV 06-05-04-04; HS6-5-4
	AISI/ASM/ ASTM/SAE/ UNS/AA (US)	D3; T30403			501; 502; S50100; S50200; K41545; SA213 T5	M50; T11350	K91231; AMS 6278	S7; T41907	M3 Class 2; T11323
	BS (UK)	BD 3							
	DIN (GERMANY)	X210Cr12; X 210 Cr 12	X38CrMoV5-3; X 38 CrMoV 5 3	27NiCrMoV15-6; 26NiCrMoV14-5; 26 NiCrMoV 14 5	X12CrMo5; X 11 CrMo 5; 12CrMo19-5; 12 CrMo 19 5; X16CrMo5-1	80MoCrV42-16; 80 MoCrV 42 16	M50NiL	50CrMoV13-4; 50 CrMoV 13 4; 50CrMoV13-15	HS6-5-3; HS 6-5-3; S 6-5-3
	Werkstoff (GERMANY)	1.2080	1.2367	1.6957	1.7362; 1.7366	1.3551	1.3590	1.2357; 1.2355	1.3344
	EN (EUROPE)	X210Cr12	X38CrMoV5-3		X12CrMo5; X16CrMo5-1	80MoCrV42-16	13MoCrNiV42-16-14	50CrMoV13-15	HS6-5-3
	GOST (RUSSIA)	Ch12							
	JIS (JAPAN)	SKD 1			SCMV 6; SFVA F 5 A; SFVA F 5 B; SFVA F 5 C; SFVA 5 D; SNB 5 Class 1; STBA 29; STFA 25; STPA 25				SKH 52; SKH 53
	SS (SWEDEN)								2725
	UNE (SPAIN)	F.521; F.5212; X 210 Cr 12			F.240.B; TU.J	80 MoCrV 40-16; F.1351			F.5605; 6-5-3
	UNI (ITALY)	X 205 Cr 12 KU							
	IS (INDIA)	T215Cr12							
	KS (REP. OF KOREA)								
	GB/YB/JB/ SY/NB (PRC)	Cr12			1Cr5Mo				









Material Designation in Accordance with Selected Standards

Standards		Material Group No.					
		10	11	11	11	11	11
	NF/AFNOR (FRANCE)			Z 110 WKCDV 07-05-04-04-02	Z 110 DKCWW 09-08-04-02-01; 2-9-1-8; HS2-9-1-8	Z 130 WKCDV 10-10-04-04-03; 10-4-3-10; HS10-4-3-10	HS12-1-4-5
	AISI/ASM/ ASTM/SAE/ UNS/AA (US)		M33; T11333; M34; T11334	M41; T11341	M42; T11342		T15; T12015
	BS (UK)		BM 34		BM 42	BT 42	BT 15
	DIN (GERMANY)	HS6-5-3C; HS 6-5-3 C	HS2-9-2-8; S 2-9-2-8	HS7-4-2-5; S 7-4-2-5	HS2-10-1-8; S 2-10-1-8	HS10-4-3-10; S 10-4-3-10	HS12-1-4-5; S 12-1-4-5
	Werkstoff (GERMANY)	1.3345	1.3249	1.3246	1.3247	1.3207	1.3202
	EN (EUROPE)	HS6-5-3C		HS7-4-2-5	HS2-10-1-8	HS10-4-3-10	
	GOST (RUSSIA)					R12F3K10M3-SCh	R13F4K5
	JIS (JAPAN)				SKH 59	SKH 57	
	SS (SWEDEN)				2716		
	UNE (SPAIN)		2-9-2-8; F.5611	F.5615; HS 7-4-2-5	F.5617; HS 2-10-1-8	F.550.B; F.5553; HS 10-4-3-10	F.5563; HS 12-1-5-5
	UNI (ITALY)				HS 2-9-1-8	HS 10-4-3-10	HS 12-1-5-5
	IS (INDIA)						
	KS (REP. OF KOREA)						
	GB/YB/JB/ SY/NB (PRC)			W7Mo4Cr4V2Co5	W2Mo9Cr4VCo8		W12Cr4V5Co5













Material Designation in Accordance with Selected Standards

Standards		Material Group No.						
		11	11	11	11	11	11	11
	NF/AFNOR (FRANCE)	6-5-2-5; 6-5-2-5 HC; HS6-5-2-5; HS6-5-2-5HC; Z 85 WDKCV 06-05-05-04-02; Z 90 WDKCV 06-05-05-04-02	Z 100 DCWV 09-04-02-02; 2-9-2; HS2-9-2	Z 80 WKCV 19-05-04-01; HS 18-1-1-5	18-0-1; HS 18-0-1; Z 80 WCV 18-04-01			
	AISI/ASM/ ASTM/SAE/ UNS/AA (US)		M7; T11307	T4; T12004	T1; T12001	HY 130; UNS K51255	H19; T20819	HY 100; K32045; J42240
	BS (UK)	BM 35		BT 4	BT 1			
	DIN (GERMANY)	HS6-5-2-5; S 6-5-2-5	HS2-9-2; S 2-9-2	HS18-1-2-5; S 18-1-2-5	HS18-0-1; S 18-0-1	X10NiMoCrV6	38CrCoWV18-17-17; 38 CrCoWV 18 17 17	20NiCrMo14-6; G19NiCrMo12-6; GS-19 NiCrMo 12 6
	Werkstoff (GERMANY)	1.3243	1.3348	1.3255	1.3355		1.2661	1.6742; 1.6783
	EN (EUROPE)	HS6-5-2-5	HS2-9-2	HS18-1-2-5	HS18-0-1		38CrCoWV18-17-17	
	GOST (RUSSIA)	R6M5K5			R18			12ChN3MD; 12ChN3MDF; AB2
	JIS (JAPAN)	SKH 55	SKH 58	SKH 3	SKH 2			
	SS (SWEDEN)	2723	2782		2750			
	UNE (SPAIN)	F.550.C; F.5613; HS 6-5-2-5	F.5607; HS 2-9-2	F.5530; HS 18-1-1-5	F.5520; HS 18-0-1			
	UNI (ITALY)	HS 6-5-2-5	HS 2 9 2	HS 18-1-1-5	HS 18-0-1			
	IS (INDIA)			T75W18Co6Cr4V1Mo75				
	KS (REP. OF KOREA)	SKH 55						
	GB/YB/JB/ SY/NB (PRC)		W2Mo9Cr4V2	W18Cr4VCo5	W18Cr4V			















Material Designation in Accordance with Selected Standards

Standards		Material Group No.								
		11	11	11	11	11	12	12	12	12
	NF/AFNOR (FRANCE)		Z 2 CN 18-10 M				Z 13 CF 17	Z 12 CAS 18		Z 8 CD 17-01
	AISI/ASM/ASTM/SAE/UNS/AA (US)	M62, T11362	K92710	K92890; AMS 6512	K93120; AMS 6514	K93540; AMS 6515	430 F; S43020			434; S43400
	BS (UK)			BS S162						434 S 17
	DIN (GERMANY)		X2NiCoMo18-8-5	X2NiCoMo18-9-5; X2NiCoMo18-8-5	X2NiCoMo18-8-5	X2NiCoMo18-12; X2NiCoMoTi18-12-4	X12CrMoS17; X 12 CrMoS 17	X10CrAlSi18; X10CrAl18	X10CrAlSi13; X10CrAl13; X 10 CrAl 13	X6CrMo17-1; X 6 CrMo 17 1
	Werkstoff (GERMANY)		1.636	1.6358; 1.6359	1.6354; 1.6359	1.6355; 1.6356	1.4104	1.4742	1.4724	1.4113
	EN (EUROPE)	HS 6-10-2	X2NiCoMo18-8-5	X2NiCoMo18-8-5	X2NiCoMo18-8-5		X12CrMoS17	X10CrAlSi18	X10CrAlSi13	X6CrMo17-1
	GOST (RUSSIA)							15Ch18SJu	10Ch13SJu	
	JIS (JAPAN)						SUS 430 F	SUS 21		SUS 434
	SS (SWEDEN)						2383			2325
	UNE (SPAIN)						F.3413	F.3113; X 10 CrAl 18	F.3152; X 10 CrAl 13	F.3116
	UNI (ITALY)						X 10 CrS 17		X 10 CrAl 12	
	IS (INDIA)									
	KS (REP. OF KOREA)									STS 434
	GB/YB/JB/SY/NB (PRC)						Y1Cr17	Cr17	1Cr13SiAl	1Cr17Mo







Material Designation in Accordance with Selected Standards

Standards		Material Group No.									
		12	12	12	12	12	12	12	12	12	12
	NF/AFNOR (FRANCE)	Z 80 CSN 20-02	Z 10 CAS 24	Z 8 C 13 FF	X 89 CrMoV 18-1	Z 8 C 12	Z 10 C 13; Z 13 C 13	Z 8 CA 12	Z 11 CF 13		Z 8 C 17
	AISI/ASM/ ASTM/SAE/ UNS/AA (US)	HNV-6; HNV6; S65006	446; S44600	429; S42900	440B; S44003	410S; 403; S41008; S40300	410; S41000; S41001; CA-15; ASTM A182 Fa	405; S40500	416; S41600		430; S43000
	BS (UK)	443 S 65				403 S 17	410 S 21; ANC 1 grade A; En 56 A	405 S 17	416 S 21; En 56 AM		430 S 17; 430 S 15; 430 S 18
	DIN (GERMANY)	X80CrNiSi20; X 80 CrNiSi 20	X10CrAlSi25; X10CrAl24; X 10 CrAl 24	X7Cr14; X 7 Cr 14; G-X 7 Cr 13	X90CrMoV18	X6Cr13; X 6 Cr 13	X12Cr13; GX12Cr13; X 12 Cr 13; X 10 Cr 13	X6CrAl13; X 6 CrAl 13	X12CrS13; X 12 CrS 13	X8Cr17	X6Cr17; X 6 Cr 17
	Werkstoff (GERMANY)	1.4747	1.4762	1.4001	1.4112	1.4000	1.4006	1.4002	1.4005	1.4015	1.4016
	EN (EUROPE)		X10CrAlSi25	X7Cr14	X90CrMoV18	X6Cr13	X13Cr13	X6CrAl13	X12CrS13		X6Cr17
	GOST (RUSSIA)					08Ch13	12Ch13; 15Ch13L				12Ch17
	JIS (JAPAN)	SUH 4	SUH 446	SUS 4105		SUS 403; SUS 403 FB; SUS 410 S	SUS 410; SUS 410 FB; SUS 410 TB; SUS 410 TKA; SUS 410 TKC; SUS F 410-A; SUS F 410-B; SUS F 410-C	SUS 405; SUS 405 TB; SUS 405 TP	SUS 416		SUS 430; SUS 430 TB; SUS 430 TKA; SUS 430 TKC; SUS 430 TP
	SS (SWEDEN)		2322			2301	2302		2380		2320
	UNE (SPAIN)	F.320B	F.3154		SUS 440B	F.3110	F.3401	F.3111	F.3411		F.310.D; F.3113
	UNI (ITALY)	X 80 CrSiNi 20				X 6 Cr 13	X 12 Cr 13 KG; X 12 Cr 13 KW	X 6 CrAl 13	X12 CrS 13		X 8 Cr 17
	IS (INDIA)	X80Cr20Si2Ni1									
	KS (REP. OF KOREA)	STR 1	STR 446			STS 403	STS 410	STS 405	STS 416		STS 430
	GB/YB/JB/ SY/NB (PRC)		2Cr25N	MiOCr18Ni12	9Cr18MoV	1Cr13; 1Cr12	1Cr13	0Cr13Al	Y1Cr13		1Cr17













Material Designation in Accordance with Selected Standards

Standards		Material Group No.								
		12	12	12	12	12	12	12	12	12
	NF/AFNOR (FRANCE)	Z 20 C 13 M	Z 33 C 13 Cl; Z 33 C 13; Z 30 C 13			Z 4 CT 17	Z 12 C 25	Z 4 CNb 17	Z 3 CT 12	Z 6 CND 16-04-01
	AISI/ASM/ ASTM/SAE/ UNS/AA (US)		420F; S42020			439; 430 Ti; S43035; S43036; XM 8	446-1		409; S40900	
	BS (UK)	ANC 1 grade B; ANC 1 grade C; 420 C 24; 420 C 29	420 S 37; 420 S 45; En 56 C; En 56 D	452 C 11					LW 19; 409 S 19	
	DIN (GERMANY)	GX20Cr14	X30Cr13; X 30 Cr 13	GX120Cr29; G-X 120 Cr 29	X20CrMo13; X 20 CrMo 13	X3CrTi17; X 6 CrTi 17	X18CrN28	X3CrNb17; X 6 CrNb 17	X2CrTi12; X 6 CrTi 12	X4CrNiMo16-5-1; X 4 CrNiMo 16 5
	Werkstoff (GERMANY)	1.4027	1.4028	1.4086	1.4720	1.4510	1.4749	1.4511	1.4512	1.4418
	EN (EUROPE)		X30Cr13			X3CrTi17	X18CrN28	X3CrNb17	X2CrTi12	X4CrNiMo16-5-1
	GOST (RUSSIA)	20Ch13L	30Ch13			08Ch17T				
	JIS (JAPAN)	SCS 2	SUS 420 F; SUS 420 J 2; SUS 420 J 2-CSP; SUS 420 J 2 FB; SUS 420 J 2 TKA			SUS 430 LX; SUS 430 LXTB; SUS XM8TB		SUS 430 LX; SUS 430 LXTB	SUH 409 L; SUS 409 LTB; SUS 409 TB	
	SS (SWEDEN)		2304							2387
	UNE (SPAIN)		F.3403			F.3115; X 5 CrTi 17		F.3122; X 5 CrNb 17	F.3121	
	UNI (ITALY)		X 30 Cr 13			X 6 CrTi 17		X 6 CrNb 17	X 6 CrTi 12	
	IS (INDIA)		X30Cr13							
	KS (REP. OF KOREA)		STS 420J2			STS 430LX		STS 430LX	SUH 409	
	GB/YB/JB/ SY/NB (PRC)	ZG2Cr13	3Cr13			1Cr17Ti		1Cr17		















Material Designation in Accordance with Selected Standards

Standards		Material Group No.							
		12	12	12	13	13	13	13	13
	NF/AFNOR (FRANCE)	Z 20 C 13 Cl; Z 20 C 13	TU Z 10 CDVNA 49-213; TU Z 10 CDVNA 49-219	Z 3 CDT 18-02; Z 3 CDT 18-2	Z 40 C 14 Cl; Z 40 C 14		Z 20 CDNbV 11	Z 20 C 13 Cl; Z 20 C 13	Z 44 C 14 Cl; Z 44 C 14; Z 38 C 13 M
	AISI/ASM/ ASTM/SAE/ UNS/AA (US)	420; S42000	K91560; K90901; P91; F91; T91	443; 444; S44300; S44400	420; S42000; S42080			420; S42000	420; S42000
	BS (UK)	420 S 37; 420 S 29; En 56 C				BS 762		420 S 37; 420 S 29; En 56 C	
	DIN (GERMANY)	X20Cr13; X 20 Cr 13	X10CrMoVNb9-1; X 10 CrMoVNb 9 1	X2CrMoTi18-2; X 2 CrMoTi 18 2	X39Cr13; X 38 Cr 13	X20CrMoV11-1-1; X20CrMoV12-1-1; X 20 CrMoV 12 1	X22CrMoV12-1-1; X21CrMoNiV12-1-1; X 22 CrMoV 12 1	X20Cr13; X 20 Cr 13	X46Cr13; X 46 Cr 13
	Werkstoff (GERMANY)	1.4021	1.4903	1.4521	1.4031	1.4922	1.4923; 1.4934	1.4021	1.4034
	EN (EUROPE)	X20Cr13	X10CrMoVNb9-1	X2CrMoTi18-2	X39Cr13	X20CrMoV11-1-1; X20CrMoV12-1-1	X22CrMoV12-1-1; X21CrMoNiV12-1-1	X20Cr13	X46Cr13
	GOST (RUSSIA)	20Ch13			40Ch13		18Ch11MNFb; EP 291; 2Ch11MFBn	20Ch13	40Ch13
	JIS (JAPAN)	SUS 420 J 1; SUS 420 J 1 FB; SUS 420 J 1 TKA		SUS 444; SUS 444 TB; SUS 444 TP	SUS 420 J 2			SUS 420 J 1; SUS 420 J 1 FB; SUS 420 J 1 TKA	
	SS (SWEDEN)	2303		2326	2304	2317		2303	
	UNE (SPAIN)	F.310.J; F.3402		F.3123; X 2 CrMoTiNb 18 2	F.3404; X40 Cr 13			F.310.J; F.3402; X 20 Cr 13	F.3405; X 40 Cr 13
	UNI (ITALY)	X 20 Cr 13			X 40 Cr 14	X 20 CrMoNi 12 01		X 20 Cr 13	X 40 Cr 14
	IS (INDIA)	X20Cr13						X20Cr13	
	KS (REP. OF KOREA)			STS 444					
	GB/YB/JB/ SY/NB (PRC)	2Cr13		1Cr15	3Cr13			2Cr13	4Cr13















Material Designation in Accordance with Selected Standards

Standards		Material Group No.							
		13	13	13	13	13	13	13	
	NF/AFNOR (FRANCE)	Z 15 CN 16.02 C1; Z 15 CN 16-02	Z 6 CN 13-04; Z 6 CN 13-4; Z 4 CND 13.4 M			Z 45 CS 9	X40Cr14; Z 40 C 14	Z 4 CND 13 4 M	MARVAL X12H
	AISI/ASM/ ASTM/SAE/ UNS/AA (US)	431; S43100	415; CA 6-NM; S41500; J91540; ASTM A182 F6NM		422; HNV 8; S42200	HNV 3; S65007		CA 6-NM; J91540	S10120; AMS 5935
	BS (UK)	431 S 29; En 57				401 S 45; En 52		425 C 11; 425 C 12	
	DIN (GERMANY)	X17CrNi16-2; X 20 CrNi 17 2; X 22 CrNi 17	X3CrNiMo13-4; X 4 CrNi 13 4	X39CrMo17-1; X 35 CrMo 17	X20CrMoWV12-1; X 20 CrMoWV 12 1	X45CrSi9-3; X 45 CrS 9 3; G-X 45 CrNi 9 3	X40Cr14; X 42 Cr 13	GX4CrNi13-4; G-X 5 CrNi 13 4	X1CrNiMoAlTi 12-10-2; X 1 CrNiMoAlTi 12 10 2
	Werkstoff (GERMANY)	1.4057	1.4313	1.4122	1.4935	1.4718	1.2083; 1.2083 ESR	1.4317	1.4596
	EN (EUROPE)	X17CrNi16-2	X3CrNiMo13-4	X39CrMo17-1	X20CrMoWV12-1	X45CrSi9-3	X40Cr14	GX4CrNi13-4	X1CrNiMoAlTi 12-10-2
	GOST (RUSSIA)	14Ch17N2; 20Ch17N2				40Ch9S2; 4Ch9S2			
	JIS (JAPAN)	SUS 431; SUS 431 FB				SUH 1	SUS 420 J 2	SCS 6; SCS 6X	
	SS (SWEDEN)	2321	2384				2314		
	UNE (SPAIN)	F.313; F.3427; X 19 CrNi 17 2				F.322; F.3220	F.5263; X 40 Cr 13		
	UNI (ITALY)	X16 CrNi 16		X 39 CrMo 17-1		X 45 CrSi 8	X 41 Cr 13 KU	GX 6 CrNi 13 04	
	IS (INDIA)					X45Cr9Si3			
	KS (REP. OF KOREA)	STS 431				STR 1			
	GB/YB/JB/ SY/NB (PRC)	1Cr17Ni2				4Cr9Si2	3Cr13		















Material Designation in Accordance with Selected Standards

Standards	Material Group No.		Material Group No.					
	13	13	14	14	14	14	14	14
 NF/AFNOR (FRANCE)	Z 100 CD 17 Cl; Z 100 CD 17		Z 6 CNT 18-10		Z 6 CND 17-11; Z 6 CND 17-11-02-FF; Z 7 CND 17-11-02; Z 7 CND 17-12-02	Z20CNS25.04	Z 10 CN 18.9 M	
 AISI/ASM/ASTM/SAE/UNS/AA (US)	440C; S44004; S44025		321; S32100		316; 316H; 316 H; S31600; S31609		J92701	
 BS (UK)			321 S 31; LW 18; LW 24; LWCF 18; LWCF 24; 321 S 12; 321 S 50; 321 S 51; 321 S 50-490; 1010; 1115		316 S 31; 316 S 33; 316 S 17; 316 S 19; 316 S 40; 316 S 41; 845		ANC 3 grade A; ANC 3 A; 302 C 25	
 DIN (GERMANY)	X105CrMo17; X105 CrMo 17	GX4CrNiMo16-5-1; G-X 5 CrNiMo 15 5	X6CrNiTi18-10	X2CrNiMo18-13-3	X5CrNiMo17-12-2; X 5 CrNiMo 18 10	X20CrNiSi25-4	GX10CrNi18-8	GX7CrNiMoCuNb18-18; G-X 7 CrNiMoCuNb 18 18
 Werkstoff (GERMANY)	1.4125	1.441	1.4541	1.4425	1.4401	1.4821	1.4312	1.4585
 EN (EUROPE)	X105CrMo17		X6CrNiTi18-10		X5CrNiMo17-12-2	X20CrNiSi25-4		
 GOST (RUSSIA)	95Ch18; 110Ch18M-SchD		06Ch18N10T; 08Ch18N10T; 09Ch18N10T; 12Ch18N10T		08Ch16N11M3		10Ch18N9L	
 JIS (JAPAN)	SUS 440 C		SUS 321		SUS 316; SUS 316 A; SUS 316 FB; SUS 316 HFB; SUS 316 HTB; SUS 316 HTP; SUS 316 TB; SUS 316 TBS		SCS 12; SCS 13A	
 SS (SWEDEN)			2337		2347			
 UNE (SPAIN)			F.332; F.3523; X 6 CrNiTi 18 10		F.310.A; F.3534; X 5 CrNiMo 17 12 2			
 UNI (ITALY)			X 6 CrNiTi 18 11; X 6 CrNiTi 18 11 KG; X 6 CrNiTi 18 11 KW; X 6 CrNiTi 18 11 KT		X 5 CrNiMo 17 12; X 5 CrNiMo 17 12 KG; X 5 CrNiMo 17 12 KW			X 6 CrNiMoTi 17 12
 IS (INDIA)								
 KS (REP. OF KOREA)			STS 321		STS 316		SSC 13A	
 GB/YB/JB/SY/NB (PRC)	9Cr18		1Cr18Ni9Ti		0Cr17Ni12Mo2		ZG0Cr18Ni9Ti	



Material Designation in Accordance with Selected Standards

Standards		Material Group No.						
		14	14	14	14	14	14	14
	NF/AFNOR (FRANCE)	Z 4 CNNb 19.10 M; Z 6 CNNb 18.10 M	23 NCDU 25.20 M	Z 4 CN 19-10 FF; Z 5 CN 17-08; Z 6 CN 18-09; Z 7 CN 18-09	Z 1 CN 18-12; Z 2 CN 18-10; Z 3 CN 19.10 M; Z 3 CN 18-10; Z 3 CN 19-11; Z 3 CN 19-11 FF	Z 6 CN 18.10 M; Z 6 CN 19.9 M	Z 10 CND 18.9 M	Z 12 CMN 17-07 Az
	AISI/ASM/ ASTM/SAE/ UNS/AA (US)	347; J92640; J82710		304; S30400	304L; 304 L; S30403; J92500; J92600	304H; 304 H; CF-8; J92590; J92600; J92650; J92710	J92701	201; S20100
	BS (UK)	347 C 17; 821 grade Nb		304 S 15; 304 S 31; LW 13; LW 15; LW 21; LWCF 13; LWCF 15; 302 S 17; 304 S 16; 304 S 17; 304 S 40	304 S 11; LW 20; LWCF 20; S.536; T.74; 304 C 12; 305 S 11	304 C 15	ANC 3 grade A; ANC 3 A; 3025 S 25	
	DIN (GERMANY)	GX5CrNiNb19-11; G-X 5 CrNiNb 18 9	GX7NiCrMoCuNb25-20; G-X 7 NiCrMoCuNb 25-20	X5CrNi18-10; X 5 CrNi 18 9	X2CrNi19-11; GXCrNi19-11	GX5CrNi19-10; G-X 6 CrNi 18 9	GX10CrNi18-8; G-X 10 CrNi 18 8	X12CrMnNiN17-7-5
	Werkstoff (GERMANY)	1.4552	1.4500	1.430	1.4306; 1.4309	1.4308	1.4312	1.4372
	EN (EUROPE)	GX5CrNiNb19-11		X5CrNi18-10	X2CrNi19-11; GXCrNi19-11	GX5CrNi19-10; 58E	GX10CrNi18-8	X12CrMnNiN17-7-5
	GOST (RUSSIA)			08Ch18N10	03Ch18N11	07Ch18N9L	10Ch18N9L	
	JIS (JAPAN)	SCS 21; SCS 21 X		SUS 304; SUS 304 A; SUS 304-CSP; SUS 304 FB; SUS 304 TB; SUS 304 TBS; SUS 304 TKA; SUS 304 TKC	SCS19	SCS 13; SCS 13 A; SCS 13 X	SCS 12	SUS 201
	SS (SWEDEN)			2333; 2332	2352			
	UNE (SPAIN)	AM-X 7 CrNiNb 20 10; F.8413		F.3504; X 5 CrNi 18 10	F.310.G; F.3503; X 2 CrNi 19 10; AM-X 2 CrNi 19 10; F.8412	AM-X 7 CrNi 20 10; F.8411		
	UNI (ITALY)			X 5 CrNi 18 10; X 5 CrNi 18 10 KG; X 5 CrNi 18 10 KW; X 5 CrNi 18 10 KT	X 3 CrNi 18 11; X 2 CrNi 18 11; GX 2 CrNi 19 10			
	IS (INDIA)							
	KS (REP. OF KOREA)			STS 304				
	GB/YB/JB/ SY/NB (PRC)	ZG1Cr18Ni9Ti		0Cr19Ni9	ZG0Cr18Ni9	ZG1Cr18Ni9	ZG0Cr18Ni9Ti	1Cr17Mn6Ni5N















Material Designation in Accordance with Selected Standards

Standards		Material Group No.						
		14	14	14	14	14	14	14
	NF/AFNOR (FRANCE)	Z 6 CND 18-12-03; Z 6 CND 18-13; Z 7 CND 18-12-03	Z 2 CND 17-12; Z 3 CND 17-11-02; Z 3 CND 17-12-02; Z 3 CND 17-12-02 FF; Z 3 CND 18-12-03	Z 2 CND 17-11 Az		Z 3 CND 17-12 Az	Z 3 CND 17-12-03; Z 3 CND 18-14-03	Z 3 CND 18-14-05 Az
	AISI/ASM/ASTM/SAE/UNS/AA (US)	316; S31600	316L; 316 L; S31603; J92700; J92800	316LN; 316 LN; S31653	CF-8M; J92900	316LN; 316 LN; S31563	316L; 316 L; S31603; J92800	S31726
	BS (UK)	316 S 31; 316 S 33; LW 23; LWCF 23; 316 S 19; 316 S 40; 316 S 41; 1.4436	316 S 11; 316 S 13; 316 S 14; 316 S 30; S.161; S.537; T.75	316 S 61; 316 S 63	ANC 4 grade B; ANC 4 B; 316 C 16; 845 grade B	316 S 63	316 S 13; 316 S 11; 316 S 14; 316 S 31; LW 22; LWCF 22; 845 B	
	DIN (GERMANY)	X3CrNiMo17-13-3; X 5 CrNiMo 17 13 3	X2CrNiMo17-12-2; X2CrNiMo17-13-2; X 2 CrNiMo 17 12 2; X 2 CrNiMo 17 13 2	X2CrNiMoN17-11-2; X2CrNiMoN17-12-2; X 2 CrNiMoN 17 12 2	GX5CrNiMo 19-11-2; G-X 6 CrNiMo 18 10	X2CrNiMo17-13-3; X 2 CrNiMoN 17 13 3	X2CrNiMo18-4-3; X 2 CrNiMo18 14 3	X2CrNiMoN17-13-5; X 2 CrNiMoN 17 13 5
	Werkstoff (GERMANY)	1.444	1.4404	1.4406	1.4408	1.4429	1.4435	1.4439
	EN (EUROPE)	X3CrNiMo17-13-3	X2CrNiMo17-13-2	X2CrNiMoN17-11-2	GX5CrNiMo 19-11-2	X2CrNiMoN17-13-3	X2CrNiMo18-4-3	X2CrNiMoN17-13-5
	GOST (RUSSIA)				07Ch18N10G2S2M2L		O3Ch17N14M3	
	JIS (JAPAN)	SUS 316; SUS 316 A; SUS 316 FB; SUS 316 TB; SUS 316 TBS; SUS 316 TKA; SUS 316 TKC; SUS 316 TP	SUS 316 L; SUS 316 LFB; SUS 316 LTBS; SUS 316 LTP; SUS 316 F 316 L	SUS 316 LN; SUS F 316 LN	SCS 14; SCS 14 A; SCS 14 X	SUS 316 LN; SUS F 316 LN	SUS 316 L; SUS 316 LFB; SUS 316 LTBS; SUS 316 LTP; SUS F 316 L	
	SS (SWEDEN)	2343	2348			2375	2353	
	UNE (SPAIN)	F.3538; X 5 CrNiMo 17 13 3	F.310.K; F.3533; F.3537	F.3542; X 2 CrNiMoN 17 12 2	AM-X 7 CrNiMo 20 10; F.8414	F.3543; X 2 CrNiMoN 17 13 3	F.3533-X2 CrNiMo 17 13 2	F.3544; X 2 CrNiMoN 17 13 5
	UNI (ITALY)	X 5 CrNiMo 17 13; X 8 CrNiMo 17 13	X 2 CrNiMo 17 12	X 2 CrNiMoN 17 12		X 2 CrNiMoN 17 13	X 2 CrNiMoN 17 13; X 2 CrNiMoN 17 13 KG; X 2 CrNiMoN 17 13 KW	
	IS (INDIA)							
	KS (REP. OF KOREA)	STS 316	STS 316L	STS 316LN	SSC 14	STS 316LN	STS 316L	
	GB/YB/JB/SY/NB (PRC)	0Cr17Ni12Mo2	00Cr17Ni14Mo2	00Cr18Ni14Mo2Cu2	ZG1Cr24Ni20Mo2Cu3	0Cr17Ni13Mo	00Cr17Ni14Mo2	















Material Designation in Accordance with Selected Standards

Standards		Material Group No.						
		14	14	14	14	14	14	14
	NF/AFNOR (FRANCE)		Z 6 CNDT 17-12	Z 15 CN 23-13; Z 15 CN 24-13			Z 5 CN 18-09	Z 4 CNDNb 18.12 M
	AISI/ASM/ ASTM/SAE/ UNS/AA (US)	317; S31700	316 Ti; S31635	309S; 309 S; 309; S30908; S30900	S30415	S30815	304H; 304 H; S30409; S30480	
	BS (UK)	317 S 16	320 S 31; 320 S 18	309 S 24			304 S 50; 304 S 51; 801 grade A	ANC 4 grade C; ANC 4 C; 318 C 17; 845 grade Nb
	DIN (GERMANY)	X3CrNiMo18-12-3	X6CrNiMoTi17-12-2; X 6 CrNiMoTi 17 12 2	X12CrNi23-13; X 7 CrNi 23 14	X4CrNiSi18-10; X 4 CrNiSi 18 10	X9CrNiSiCe21-11-2; X 8 CrNiSi 21 11	X6CrNi18-10; X6CrNi18-11; X 6 CrNi 18 11;	GX5CrNiMoNb19-11-2; G X 5 CrNiMoNb 18 10
	Werkstoff (GERMANY)	1.4449	1.4571	1.4833	1.4891	1.4893	1.4948	1.4581
	EN (EUROPE)	X3CrNiMo18-12-3	X6CrNiMoTi17-12-2	X12CrNi23-13	X4CrNiSi18-10	X9CrNiSiCe21-11-2	X6CrNi18-10	GX5CrNiMoNb19-11-2
	GOST (RUSSIA)		08Ch16N11M3T; 08Ch17N13M2T; 10Ch17N13M2T					
	JIS (JAPAN)	SUS 317; SUS 317 TB; SUS 317 TP; SUS F 317	SUS 316 Ti; SUS 316 TTB; SUS 316 TTP	SUS 309 S; SUS 309 S TB; SUS 309 S TP			SUS 302	SCS 22
	SS (SWEDEN)		2350		2372	2368		
	UNE (SPAIN)		F.310.B; F.3535; X 6 CrNiMoTi 17 12 2					
	UNI (ITALY)	X 5 CrNiMo 18 15	X 6 CrNiMoTi 17 12; X 6 CrNiMoTi 17 12 KG; X 6 CrNiMoTi 17 12 KW	X 6 CrNi 23 14				GX 6 CrNiMoNb 20 11
	IS (INDIA)							
	KS (REP. OF KOREA)	STS 317		SSC17			STS 302	SSC 22
	GB/YB/JB/ SY/NB (PRC)	1Cr18Ni12Mo3Ti	1Cr18Ni12Mo2Ti	1Cr23Ni13			1Cr18Ni9	ZG1Cr18Mn8Ni4N





Material Designation in Accordance with Selected Standards

		Material Group No.						
Standards		14	14	14	14	14	14	14
	NF/AFNOR (FRANCE)	Z 8 CNF 18-09	Z 1 CN 18-12; Z 3 CN 18-10; Z 3 CN 19-11; Z 3 CN 19-11 FF	Z 11 CN 17-08; Z 11 CN 18-08; Z 12 18-09	Z 3 CN 18-10 Az; Z 3 CN 18-07 Az	Z 6 CN 18.09	Z 2 CND 19-15-04; Z 3 CND 19-15-04	Z 6 CNT 18-10
	AISI/ASM/ ASTM/SAE/ UNS/AA (US)	303; S30300	304L; 304 L; S30403	301; J 230; S30100; S30200	304LN; 304 LN; S30453	304B1; 304B2; 304B3; 304 B1; 304 B2; 304 B3; S30461; S30462; S30463	317L; 317 L; S31703	321H; 321 H; S32109
	BS (UK)	303 S 31	304 S 11; LW14; LW 20; LWCF 14; LWCF 20; S.536; T.74; 304 C 12; 304 S 11	301 S 21; 301 S 22	304 S 61	304 S 31	317 S 12	321 S 31
	DIN (GERMANY)	X8CrNiS18-9; X 10 CrNiS 18 9	X2CrNi19-11; X 2 CrNi 19 11	X10CrNi18-8; X 12 CrNi 17 7	X2CrNiN18-10; X 2 CrNiN 18 10	X5CrNi18-9	X2CrNiMo18-15-4; X2 CrNiMo 18 16 4	X12CrNiTi18-10; X 12 CrNiTi 18-9
	Werkstoff (GERMANY)	1.4305	1.4306	1.4310	1.4311	1.4350	1.4438	1.4878
	EN (EUROPE)	X8CrNiS18-9; 58M	X2CrNi19-11	X10CrNi18-8	X2CrNiN18-10	58E	X2CrNiMo18-15-4	X12CrNiTi18-10; 58B
	GOST (RUSSIA)	30Ch18N11	03Ch18N11	12Ch18N9				
	JIS (JAPAN)	SUS 303	SUS 304 L; SUS 304 LFP; SUS 304 LTb; SUS 304 LTBS; SUS 304 LTP; SUS F 304 L	SUS 301; SUS 301-CSP; SUS 302; SUS 302 FB	SUS 304 LN; SUS F 304 LN		SUS 317 L; SUS 317 LFB; SUS 317 LTb; SUS 317 LTP; SUS F 317 L; SUS Y 317 L	SUS 321; SUS 321 HFB; SUS 321 HTb; SUS 321 HTP; SUS 321 TKA; SUS 321 TP; SUS F 321; SUS Y 321
	SS (SWEDEN)	2346	2352	2331	2371	2332; 2333	2367	2337
	UNE (SPAIN)	F.310.C; F.3508; X 10 CrNiS 18-09	F.310.G; F.3503; X 2 CrNi 18 10	F.3517; X 2 CrNiN 18 10	F.3541; X 2 CrNiN 18 10	F.3551	F.3539; X2 CrNiMo 18 16 4	F.3553
	UNI (ITALY)	X 10 CrNiS 18 09	X 2 CrNi 18 11; X 3 CrNi 18 11	X 12 CrNi 17 07	X 2 CrNiN 18 11	X 5 CrNi 18 10	X 2 CrNiMo 18 16	X 6 CrNiTi 18.11
	IS (INDIA)							
	KS (REP. OF KOREA)	STS 303	STS 304L	STS 302	STS 304LN	STS 304L	STS 317L	STS 321
	GB/YB/JB/ SY/NB (PRC)	1Cr18Ni9MoZr	00Cr19Ni10	Cr17Ni7	00Cr18Ni10N	0Cr18Ni9	00Cr19Ni13Mo	0Cr18Ni9Ti















Material Designation in Accordance with Selected Standards

Standards		Material Group No.						
		14	14	14	14	14	14	14
	NF/AFNOR (FRANCE)	Z 6 CnNb 18-10	Z 6 CNDNb 18-12		Z 9 CN 24-13; Z 17 CNS 20-12	Z 15 CNS 25-20		Z 10 CNT 18-11; 9160/C 63; 9160C201
	AISI/ASM/ ASTM/SAE/ UNS/AA (US)	347; 348; S34700; S34800	318; S31803		309; S30900	310; 314; S3100; S31400; S31500	348; S34800	
	BS (UK)	347 S 31; ANC 3 grade B; ANC 3 B; 347 S 20; 347 S 40; 347 S 50; 347 S 51			309 S 24	314 S 25	2 S.130; 2 S.143; 3 S.144; 3 S.145; S.525; S.527	S.524; S.526; 2 S 129
	DIN (GERMANY)	X6CrNiNb18-10; X 6 CrNiNb 18 10	X10CrNiMoNb18-12; X 10CrNiMoNb 18 12	X1CrNiMoN25-22-2; X 2 CrNiMoN 25 22 7	X15CrNiSi20-12; X 15 CrNiSi 20 12	X15CrNiSi25-21; X 15 CrNiSi 25 20	X5CrNiNb18-10	
	Werkstoff (GERMANY)	1.4550	1.4583	1.4465; 1.4466	1.4828	1.4841	1.4546	1.4544; 1.4544.9
	EN (EUROPE)	X6CrNiNb18-10; 58F;		X1CrNiMoN25-22-2	58C; X15CrNiSi20-12	X15CrNiSi25-21		FE-PA 13
	GOST (RUSSIA)	08Ch18N12B			20Ch20N14S2	20Ch25N20S2		08Ch18N12T
	JIS (JAPAN)	SUS 347; SUS 347 FB; SUS 347 HTB; SUS 347 TB; SUS 347 TKA; SUS 347 TP; SUS F 347			SUH 309; SUS 309 TB; SUS 309 TP	SUH 310; SUS 310 TB; SUS Y 310		
	SS (SWEDEN)	2338						
	UNE (SPAIN)	F.3524; X 6 CrNiNb 18 10			F.3312; X 15 CrNiSi 20-12	F.3310; X 15 CrNiSi 25-20		
	UNI (ITALY)	X 6 CrNiNb 18 11; X 6 CrNiNb 18 11 KG; X 6 CrNiNb 18 11 KW; X 6 CrNiNb 18 11 KT	X 6 CrNiMoNb 20 11		X 16 CrNi 23 14	X 16 CrNiSi 25 20		X 6 CrNiTi 18 11
	IS (INDIA)							
	KS (REP. OF KOREA)	STS 347				STR 310		
	GB/YB/JB/ SY/NB (PRC)	1Cr18Ni11Nb	Cr17Ni12Mo3Mb		1Cr20Ni14Si2	1Cr25Ni20Si2		

Material Designation in Accordance with Selected Standards

Standards		Material Group No.						
		14	14	14	14	14	14	14
	NF/AFNOR (FRANCE)			Z 3 CND 19.10 M	Z 3 CN 19.10 M		Z 2 CN 18 10	Z 6 CNU 18 10
	AISI/ASM/ASTM/SAE/UNS/AA (US)			316N; 316 N; J92804	304L; 304 L J92500; J92620			302 HQ; 304 Cu; 304 HQ; XM-7; EV-17; S30430
	BS (UK)				304 C 12		304 S 12	394 S 17
	DIN (GERMANY)	X12CrNi18-9; X 12 CrNi 18 9	X12CrNi22-12; X 12 CrNi 22 12	GX2CrNiMo19-11-2; G-X 2 CrNiMo 19 11 2	GX2CrNi19-11	GX2CrNiMnMoNb21-15-4-3; G-X 2 CrNiMnMoNb 21 15 43	X2CrNi18-9; X 2 CrNi 18 9	X3CrNiCu18-9-4; X 3 CrNiCu 18 9
	Werkstoff (GERMANY)	1.6900	1.4829	1.4409	1.4309	1.4569	1.431	1.457
	EN (EUROPE)			GX2CrNiMo19-11-2	GX2CrNi19-11		X2CrNi18-9	X3CrNiCu18-9-4
	GOST (RUSSIA)							
	JIS (JAPAN)			SCS 16 A; SCS 16 AX SCS 16 AXN	SCS 19; SCS 19 A			SUS XM 7
	SS (SWEDEN)							
	UNE (SPAIN)			AM-X 2 CrNiMo 19 11; F.8415	AM-X 2 CrNi 19 10; F.8412			
	UNI (ITALY)			GX2 CrNiMo 19 11	GX 2 CrNi 19 10			
	IS (INDIA)							
	KS (REP. OF KOREA)				SSC 19			
	GB/YB/JB/SY/NB (PRC)				ZG00Cr18NiCe0			















Material Designation in Accordance with Selected Standards

Standards		Material Group No.							
		14	14	14	14	14	14	14	14
	NF/AFNOR (FRANCE)				Z 5 CN 18-11 FF				
	AISI/ASM/ ASTM/SAE/ UNS/AA (US)	S21800; AMS 5848	S20910; XM-19	S24100; XM-28	305; 308; S30500; S30800	S31630			
	BS (UK)				305 S 17; 305 S 19				
	DIN (GERMANY)		X2CrNiMnMoNb21-16-5-3		X4CrNi18-12; X 5 CrNi 18 12		GX6CrNiMo18-12; G-X 6 CrNiMo 18 12	GX2CrNiMoM17-13-4	GX6CrNiMo17-13; G-X 6 CrNiMo 17 13
	Werkstoff (GERMANY)		1.396		1.430		1.444	1.445	1.445
	EN (EUROPE)				X4CrNi18-12			GX2CrNiMoM17-13-4	
	GOST (RUSSIA)				06Ch18N11				
	JIS (JAPAN)				SUS 305 J 1; SUS 305				
	SS (SWEDEN)								
	UNE (SPAIN)				F.3513; X 8 CrNi 18 12				
	UNI (ITALY)				X 7 CrNi 18 10; X 8 CrNi 19 10				
	IS (INDIA)								
	KS (REP. OF KOREA)								
	GB/YB/JB/ SY/NB (PRC)								







Material Designation in Accordance with Selected Standards

Standards		Material Group No.					
		14	14	14	14	14	14
	NF/AFNOR (FRANCE)		Z 2 NCDU 25-20		Z 8 CN 25-20; Z 12 CN 25-20; Z 12 CN 26-21		Z 52 CMN 21-09 Az; Z 53 CMN 21-09 Az
	AISI/ASM/ ASTM/SAE/ UNS/AA (US)	J93254; CK3MCoN	904L; 904 L; N08904		310H; 310 H; 310S; 310 S; S31008; S31009	254 SMO; S31254; F44	EV 8; S63008
	BS (UK)		904 S 13		310 S 16; 310 S 24; 310 S 25; 310 S 31		349 S 52
	DIN (GERMANY)	GX2CrNiMoCuN20-18-6	X1NiCrMoCu25-20-5; X 1 NiCrMoCuN 25 20 5	GX1NiCrMoCuN25-20-5; G-X 1 NiCrMoCuN 25 20 5	X8CrNi25-21; X 12 CrNi 25 21	X1CrNiMoN20-18-7	X53CrMnNiN21-9; X 53 CrMnNiN 21 9
	Werkstoff (GERMANY)	1.456	1.4539	1.454	1.4845	1.4547	1.4871
	EN (EUROPE)	GX2CrNiMoCuN20-18-6	X1NiCrMoCu25-20-5		X12CrNi25-21	X1CrNiMoN20-18-7	X53CrMnNiN21-9
	GOST (RUSSIA)				10Ch23N18; 20Ch23N18		55Ch20G9AN4
	JIS (JAPAN)				SUS 310 S; SUS 310 FB; SUS 310 STG; SUS 310 STP; SUS310 TB; SYS Y 310 S		SUH 35; SUH 36
	SS (SWEDEN)		2562		2361	2378	
	UNE (SPAIN)				F.331		F.3217; X 53 CrMnNiN 21-09
	UNI (ITALY)				X 6 CrNi 25 20 (X 6 CrNi 25 20)		X 53 CrMnNiN 21 9
	IS (INDIA)						X53Cr22Mn9Ni4N
	KS (REP. OF KOREA)						STR 35; STR 36
	GB/YB/JB/ SY/NB (PRC)				0Cr25Ni20		5Cr2Mn9Ni4N

Material Designation in Accordance with Selected Standards

Standards		Material Group No.					
		14	14	14	14	14	14
	NF/AFNOR (FRANCE)	Z 6 CND 15-07; 9160/C 65; 9160C 211	Z 55 CMN 20-08 Az	Z 50 CMNNb 21.09; Z 50 CMNNb 21-09	Z 53 CMNB 21-09-02 Az		Z 9 CNA 17-07; Z 8 CNA 17-07
	AISI/ASM/ ASTM/SAE/ UNS/AA (US)	632; S15700; 15-7 PH; 15-7PH; AMS 5520; AMS 5657	EV 12; S63012	XEV-F; S63019		EV 16; S63018	631; 17-7PH; 17-7 PH; S17700
	BS (UK)				352 S 52		301 S 81
	DIN (GERMANY)	X8CrNiMoAl15-7-2; X 7 CrNiMoAl 15-7	X55CrMoNiN20-8; X 55 CrMoNiN 20 8	X50CrMnNiNbN21-9	X53CrMnNiNbN21-9; X 53 CrMnNiNbN 21 9	X33CrNiMnN23-8; X 33 CrNiMnN 23 8	X7CrNiAl17-7; X 7 CrNiAl 17 7
	Werkstoff (GERMANY)	1.4532; 1.4574	1.488	1.4882	1.487	1.487	1.4568; 1.4564; 1.4504
	EN (EUROPE)	X8CrNiMoAl15-7-2	X55CrMoNiN20-8	X50CrMnNiNbN21-9	X53CrMnNiNbN21-9	X33CrNiMnN23-8	X7CrNiAl17-7
	GOST (RUSSIA)						09Ch17N7Ju1
	JIS (JAPAN)						SUS 631; SUS 631 J 1; SUS 631-CSP
	SS (SWEDEN)						2388
	UNE (SPAIN)						X 2 CrNiMo 17 12
	UNI (ITALY)		X 55 CrMnNiN 20.8		X 53 CrMnNiNbN 21.9		
	IS (INDIA)						
	KS (REP. OF KOREA)						
	GB/YB/JB/ SY/NB (PRC)						0Cr17Ni7Al















Material Designation in Accordance with Selected Standards

Standards		Material Group No.					
		14	14	14	14	14	14
	NF/AFNOR (FRANCE)				Z 3 CN 23-04 Az	Z 5 CND 27-05 Az; Z 3 CND 25-07 Az	Z 2 CND 24-08 Az; Z 3 CND 25-06-03 Az; Z 3 CND 25 -05 Az
	AISI/ASM/ ASTM/SAE/ UNS/AA (US)	S31266	654 SMO; S32654	J94650; CN7MS	S32304	329; S31260; S32900	S31803; S31260; S32900; A182 F51; A182 Gr. F51; A182 Grade F51
	BS (UK)						318 S 13; 1.4462
	DIN (GERMANY)	X1CrNiMoCuNW24-22-6	X1CrNiMoCuN24-22-8	GX2NiCrMoCuN25-20	X2CrNiN23-4; X 2 CrNiN 23 4	X3CrNiMoN27-5-2; X 4 CrNiMoN 27 5 2	X2CrNiMoN22-5-3; X 2 CrNiMoN 22 5 3
	Werkstoff (GERMANY)	1.466	1.465	1.454	1.4362	1.4460	1.4462
	EN (EUROPE)	X1CrNiMoCuNW24-22-6	X1CrNiMoCuN24-22-8		X2CrNiN23-4	X3CrNiMoN27-5-2	X2CrNiMoN22-5-3
	GOST (RUSSIA)				03Ch3N6	10Ch26N5M; 08Ch21N6M2T	
	JIS (JAPAN)					SUS 329 J 1; SUS 329 J 1 FB; SUS 329 J 1 TB; SUS 329 J 1 TP	SUS 329 J 3 L; SUS 329 J 3 LTB; SUS 329 J 3 LTP
	SS (SWEDEN)				2327	2324	2377
	UNE (SPAIN)					F.3552; F.3309; X 8 CrNiMo 27-05; X 8 CrNiMo 26 6	
	UNI (ITALY)						
	IS (INDIA)						
	KS (REP. OF KOREA)					STS 329J1	STS 329J3L
	GB/YB/JB/ SY/NB (PRC)				0Cr26Ni5Mo2	0Cr26Ni5Mo2	

Material Designation in Accordance with Selected Standards

		Material Group No.							
Standards		14	14	14	14	14	14	14	14
	NF/AFNOR (FRANCE)						Z 2 CND 18.05.03		
	AISI/ASM/ ASTM/SAE/ UNS/AA (US)	J92605; J93005	329; S32900	S33100; A182 F10; A182 Gr. F10; A182 Grade F10			S31500		
	BS (UK)								
	DIN (GERMANY)	GX40CrNiSi27-4; G-X 40 CrNiSi 27 4	X6CrNiMo26-4-2; X 6 CrNiMo 26 4 2			GX2CrNiMoN25-6-3; G-X 3 CrNiMoN 26 6 3	GX2CrNiMoN25-7-3; G-X 2 CrNiMoN 25 7 3; X2CrNiMoSi18-5-3; X 2 CrNiMoSi 18 5 3	GX4CrNiN26-7; G-X 8 CrNiN 26-7; G-X 6 CrNiN 26-7	GX6CrNiMo24-8-2; G-X 6 CrNiMo 24 8 2
	Werkstoff (GERMANY)	1.4823	1.448			1.447	1.4417; 1.4424	1.435	1.446
	EN (EUROPE)	GX40CrNiSi27-4				GX2CrNiMoN25-6-3	GX2CrNiMoN25-7-3; X2CrNiMoSi18-5-3	GX4CrNiN26-7	
	GOST (RUSSIA)				03Ch22N6M2	03Ch24N6AM3			
	JIS (JAPAN)	SCH 11 X							
	SS (SWEDEN)						2376		
	UNE (SPAIN)								
	UNI (ITALY)								
	IS (INDIA)								
	KS (REP. OF KOREA)								
	GB/YB/JB/ SY/NB (PRC)								

Material Designation in Accordance with Selected Standards

Standards		Material Group No.					
		14	14	14	14	14	14
	NF/AFNOR (FRANCE)						Z 3 CNDU 25-06 Az
	AISI/ASM/ ASTM/SAE/ UNS/AA (US)	J92205; CD3MN 4A; A 995 Grade 4A		J93372; CD4MCuN; A890 Grade 1B; A 995 Grade 1B		J92615; CC 50; CC-50	S32760; SA351/995; 25Cr-7Ni-Mo-N
	BS (UK)						
	DIN (GERMANY)	GX2CrNiMoN22-5-3	GX3CrNiMoCuN26-6-3-3; G-X 2 CrNiMoCuN 26 6 3 3	GX2CrNiMoCuN25-6-3-3; G-X 3 CrNiMoCuN 26 6 3 3	GX32CrNi28-10	GX40CrNi27-4; G-X 40 CrNi 27 4	X2CrNiMoCuWN25-7-4
	Werkstoff (GERMANY)	1.447	1.452	1.452	1.434	1.4340	1.4501
	EN (EUROPE)	GX2CrNiMoN22-5-3		GX2CrNiMoCuN25-6-3-3			X2CrNiMoCuWN25-7-4
	GOST (RUSSIA)						
	JIS (JAPAN)			SCS 32			
	SS (SWEDEN)						
	UNE (SPAIN)						
	UNI (ITALY)						
	IS (INDIA)						
	KS (REP. OF KOREA)						
	GB/YB/JB/ SY/NB (PRC)						0Cr26Ni5Mo2

Material Designation in Accordance with Selected Standards

Standards		Material Group No.						
		14	14	14	14	14	14	14
	NF/AFNOR (FRANCE)	Z 5 CND 25-06 Az		Z 3 CNDU 25-06 Az; Z 3 CNDU 25-07 Az				
	AISI/ASM/ ASTM/SAE/ UNS/AA (US)	S32750		S32520; S32550; F61	S32950; SA276; SA479	J93380; CD3MnWCuN; A890 Grade 6A	J93503; J94003; J94013; HK 30; HH; A297-HH	J94203; J94204; J94224; HK
	BS (UK)						309 C 30	310 C 40; 310 C 45
	DIN (GERMANY)	X2CrNiMoN25-7-4; X 10 CrNiMo 18 9	GX2CrNiMoN26-7-4; G-X 2 CrNiMoN 25-7-4	X2CrNiMoCuN25-6-3		GX3CrNiMoWCuN27-6-3-1; G-X 3 CrNiMoWCuN 27 6 3 1	GX40CrNiSi25-12; G-X 40 CrNiSi 25 12	GX40CrNiSi25-20; G-X 40 CrNiSi 25 20
	Werkstoff (GERMANY)	1.4410	1.447	1.451		1.447	1.4837; 1.4848+Nb	1.4848
	EN (EUROPE)	X2CrNiMoN25-7-4	GX2CrNiMoN26-7-4	X2CrNiMoCuN25-6-3			GX40CrNiSi25-12	GX40CrNiSi25-20
	GOST (RUSSIA)						40Ch24N12SL	
	JIS (JAPAN)						SCH 13; SCH 13 A; SCH 13 X; SCH 17; SCS 17	SCH 21; SCH 22; SCH 22 X
	SS (SWEDEN)	2328						
	UNE (SPAIN)							AM-X 40 CrNi 25 20; F.8452
	UNI (ITALY)						G X 35 CrNi 25 12	G X 40 CrNi 26 20
	IS (INDIA)							
	KS (REP. OF KOREA)						SSC 17	HRSC 21; HRSC 22
	GB/YB/JB/ SY/NB (PRC)							ZG4Cr25Ni20Si2

Material Designation in Accordance with Selected Standards

Standards		Material Group No.						14
		14	14	14	14	14	14	
	NF/AFNOR (FRANCE)							
	AISI/ASM/ ASTM/SAE/ UNS/AA (US)				J94202; CK 20; AMS 5365; A351; A743			
	BS (UK)							
	DIN (GERMANY)	GX40NiCrSiNb38-19; G-X 40 NiCrSi 38 18	GX40NiCrSiNb35-26; G-X 40 NiCrSiNb 35 25	GX25CrNiSi20-14	GX15CrNi25-20	GX40CrNiSiNb24-24; G-X 30 CrNiSiNb 24 24	GX40NiCrSi35-26; G-X 40 NiCrSi 35 25	GX25CrNiSi18-9; G-X 25 CrNiSi 18 9
	Werkstoff (GERMANY)	1.4849	1.485	1.483	1.484	1.486	1.486	1.483
	EN (EUROPE)	GX40NiCrSiNb38-19	GX40NiCrSiNb35-26	GX25CrNiSi20-14		GX40CrNiSiNb24-24	GX40NiCrSi35-26	GX25CrNiSi18-9
	GOST (RUSSIA)							
	JIS (JAPAN)				SCS 18	SCH 33	SCH 24 X	
	SS (SWEDEN)							
	UNE (SPAIN)							
	UNI (ITALY)							
	IS (INDIA)							
	KS (REP. OF KOREA)							
	GB/YB/JB/ SY/NB (PRC)							

Material Designation in Accordance with Selected Standards

Standards		Material Group No.			Material Group No.				
		14	14	14	15	15	15	15	15
	NF/AFNOR (FRANCE)				Ft 10 D		Ft 15 D; R 15 D; FGL 150		Ft 20 D; FGL 200
	AISI/ASM/ ASTM/SAE/ UNS/AA (US)		N08151; CT15C		F11401; A48-20; A48-20 B; Class 20; No 20 B	H10 J431	F11701; A48-25; A48 25 B; Class 25; No 25 B; G9H12 J431	H11 J431	F12101; A48-30; A48-30 B; Class 30, No.30 B; G110H18 J431
	BS (UK)				Grade 100		Grade 150		Grade 220
	DIN (GERMANY)	GX40CrNiSi22-10; G-X 40 CrNiSi 22 9	GX10NiCrSiNb32-20; G-X 10NiCrNb 32 20	GX50NiCrCoW35-25-15-5; G-X 50 NiCrCoWSi 35 25 15 5	EN-GJL-100; EN-JL 1010; GG-10	EN-GJL-HB155; EN-JL 2010; GG-150 HB	EN-GJL-150; EN-GJL-150C; EN-JL 1020; GG-15	EN-GJL-HB175; EN-JL 2020; GG-170 HB	EN-GJL-200; EN-GJL-200C; EN-JL 1030; GG-20
	Werkstoff (GERMANY)	1.483	1.486	1.487	0.6010; 5.1100	0.6012; 5.1101	0.6015; 5.1200	0.6017; 5.1201	0.6020; 5.1300
	EN (EUROPE)	GX40CrNiSi22-10	GX10NiCrSiNb32-20	GX50NiCrCoW35-25-15-5	EN-GJL-100; EN-JL 1010	EN-GJL-HB155; EN-JL 2010	EN-GJL-150; EN-GJL-150C; EN-JL 1020	EN-GJL-HB175; EN-JL 2020	EN-GJL-200; EN-GJL-200C; EN-JL 1030
	GOST (RUSSIA)				SCh10		SCh 15		SCh 20
	JIS (JAPAN)	SCH12	SCH 34	SCH 46	FC 10; FC 100		FC 15; FC 150		FC 20; FC 200
	SS (SWEDEN)				0110-00		0115-00		0120-00
	UNE (SPAIN)				FG 10		FG 15		FG 20
	UNI (ITALY)				G 10		G 14; G 15		G 20; Gh 190
	IS (INDIA)								
	KS (REP. OF KOREA)				GC 10		GC 15		GC 20
	GB/YB/JB/ SY/NB (PRC)				HT100		HT150		HT200

Material Designation in Accordance with Selected Standards

Standards		Material Group No.							
		15	15	15	16	16	16	16	16
	NF/AFNOR (FRANCE)				Ft 25 D; FGL 250	Ft 30 D; FGL 300	Ft 35 D; FGL 350		
	AISI/ASM/ ASTM/SAE/ UNS/AA (US)	F10004; G1800; A159 Grade G1800	F10005; G2500; A159 Grade G2500	F10009; G2500a; A159 Grade G2500a	F12401; A48-40; A48-40 B; Class 40; No 40 B; A278-35; G11H20	F13101; A48-45; A48-45 B; Class 45; No 45 B; A278-45	F13501; A48-50; A48-50 B; Class 50; No 50 B; A278-50	H13 J431; H14 J431	H16 J431
	BS (UK)				Grade 260; Grade 250	Grade 300	Grade 350		
	DIN (GERMANY)				EN-GJL-250; EN-GJL-250C; EN-JL1040; GG-25	EN-GJL-300; EN-GJL-300C; EN-JL 1050; GG-30	EN-GJL-350; EN-GJL-350C; EN-JL 1060; GG-35	EN-GJL-HB195; EN-JL2030; GG-190 HB	EN-GJL-HB215; EN-JL2040; GG-220 HB
	Werkstoff (GERMANY)				0.6025; 5.1301	0.6030; 5.1302	0.6035; 5.1303	0.6022; 5.1304	0.6027; 5.1305
	EN (EUROPE)				EN-GJL-250; EN-GJL-250C; EN-JL1040	EN-GJL-300; EN-GJL-300C; EN-JL 1050	EN-GJL-350; EN-GJL-350C; EN-JL 1060	EN-GJL-HB195; EN-JL2030	EN-GJL-HB215; EN-JL2040
	GOST (RUSSIA)				SCh 25	SCh 30	SCh 35		
	JIS (JAPAN)				FC 25; FC250	FC 30; FC 300	FC 35; FC350		
	SS (SWEDEN)				0125-00	0130-00	0135-00		
	UNE (SPAIN)				FG 25	FG 30	FG 35		
	UNI (ITALY)				G 25	G 30	G 35		
	IS (INDIA)								
	KS (REP. OF KOREA)				GC 25; GC 250	GC 30	GC 350		
	GB/YB/JB/ SY/NB (PRC)				HT250	HT300	HT350		















Material Designation in Accordance with Selected Standards

Standards		Material Group No.							16
		16	16	16	16	16	16	16	
	NF/AFNOR (FRANCE)				Ft 40 D				
	AISI/ASM/ ASTM/SAE/ UNS/AA (US)	H18 J431	H20 J431	F13801; A48-55; A48-55 B; Class 55; No 60 B	F14101; A48-60 B; Class 60; No 60 B	F10006; G3000; A159 Grade G3000	F10007; G3500; A159 Grade G3500	F10010; G3500b; A159 Grade G3500b	F10011; G3500c; A159 Grade G3500c
	BS (UK)				Grade 400				
	DIN (GERMANY)	EN-GJL-HB235; EN-JL2050; GG-240 HB	EN-GJL-HB255; EN-JL2060; GG-260 HB		EN-JLZ; GG-40				
	Werkstoff (GERMANY)	0.6032; 5.1306	0.6037; 5.1307		0.6040				
	EN (EUROPE)	EN-GJL-HB235; EN-JL2050	EN-GJL-HB255; EN-JL2060		EN-JLZ				
	GOST (RUSSIA)				SCh 40				
	JIS (JAPAN)								
	SS (SWEDEN)				0140-00				
	UNE (SPAIN)								
	UNI (ITALY)								
	IS (INDIA)								
	KS (REP. OF KOREA)								
	GB/YB/JB/ SY/NB (PRC)				HT400				















Material Designation in Accordance with Selected Standards

Standards		Material Group No.						
		16	16	17	17	17	17	17
	NF/AFNOR (FRANCE)			FGS 370-17			FGS 370-17	
	AISI/ASM/ASTM/SAE/UNS/AA (US)	F10008; G4000; A159 Grade G4000	F10012; G4000d; A159 Grade G4000d				F32800; 60-40-18; A395 60-40-18; A536 60-40-18	
	BS (UK)			350/22 L 40			370/17; Grade 370/17; 400/18; Grade 400/18; SG 24/17	
	DIN (GERMANY)			EN-GJS-350-22-LT; GGG-35.3			EN-GJS-400-18-LT; EN-GJS-400-18C-LT; EN-GJS-400-18U-LT; EN-JS1025; EN-JS1049; GGG-40.3	
	Werkstoff (GERMANY)			0.7033; 5.3100	5.310	5.310	0.7043; 5.3103	5.310
	EN (EUROPE)			EN-GJS-350-22-LT; EN-GJS-350-22C-LT; EN-GJS-350-22U-LT; EN-JS1015; EN-JS1019	EN-GJS-350-22-RT; EN-GJS-350-22C-RT; EN-GJS-350-22U-RT; EN-JS1014; EN-JS1029	EN-GJS-350-22; EN-GJS-350-22C; EN-GJS-350-22U; EN-JS1010; EN-JS1032; EN-JS2010	EN-GJS-400-18-LT; EN-GJS-400-18C-LT; EN-GJS-400-18U-LT; EN-JS1025; EN-JS1049	EN-GJS-400-18-RT; EN-GJS-400-18C-RT; EN-GJS-400-18U-RT; EN-JS1024; EN-JS1059
	GOST (RUSSIA)			VCh 42-12	VCh 35	VCh 35	VCh 42-2	
	JIS (JAPAN)			FCD 350-22L	FCD 350-22	FCD 350-22	FCD 400-18L; FCD 400-18AL; FCD 370	FCD 400-18; FCD 400-18A
	SS (SWEDEN)						0717-15	
	UNE (SPAIN)			FNG 38-17				
	UNI (ITALY)			GS 370/17			GSO 42/15	
	IS (INDIA)							
	KS (REP. OF KOREA)							
	GB/YB/ JB/ SY/NB (PRC)			QT350-22L				













Material Designation in Accordance with Selected Standards

Standards		Material Group No.								
		17	17	17	17	18	18	18	18	
	NF/AFNOR (FRANCE)		FCS 400-12; FCS 400-12	FGS 450-10			FGS 500-7	FGS 600-3	FGS 700-2	
	AISI/ASM/ ASTM/SAE/ UNS/AA (US)	F32800; 60-40-18; A395 60-40-18; A536 60- 40-18; D400 J434; D4018 J434	F32800; 60-40-18; A395 60-40-18; A536 60-40-18	F33100; A395 65-45-15; 65-45-15; A536 65-45-12; 65-45-12			F33500; D5006 J 434; D5006	F33800; A536 80-55-06; 80-55-06; F34100; A538 80-60-03; 80-60-03	F34800; A536 100-70-03; 100-70-03; A536 100-70-03; D700 J434; D7003 J434	
	BS (UK)	400/18; Grade 400/18; SG 24/17	420/12; Grade 420/12	420/12; Grade 420/12; SG 27/12			500/7; Grade 500/7; SG 32/7	600/3; Grade 600/3	700/2; Grade 700/2; SG42/2; SNG700/2	
	DIN (GERMANY)		EN-GJS-400-15; EN-GJS-400-15C; EN-GJS-400-15U; EN-GJS-HB155; EN-JS 1030; EN-JS1072; EN-JS2030; GGG-40				EN-GJS-500-7; EN-GJS-500-7C; EN-GJS-500-7U; EN-GJS-HB200; EN-JS-1050; EN-JS-1082; EN-JS-2050; GGG-50	EN-GJS-600-3; EN-GJS-600-3C; EN-GJS-600-3U; EN-GJS-HB230; EN-JS1060; EN-JS1092; EN-JS2060; GGG-60	EN-GJS-700-2; EN-JS 1070; GGG-70	
	Werkstoff (GERMANY)	0.7043; 5.3105	0.7040; 5.3106	5.311	5.311	0.7050; 5.3200	0.7060; 5.3201	0.7070; 5.3300	5.311	
	EN (EUROPE)	EN-GJS-400-18; EN-GJS-400-18-C; EN-GJS-400-18U; EN-GJS-HB-150; EN-JS1020; EN_JS1062; EN-JS-2020	EN-GJS-400-15; EN-GJS-400-15C; EN-GJS-400-15U; EN-GJS-HB155; EN-JS 1030; EN-JS1072; EN-JS2030	EN-GJS-450-10; EN-GJS-450-10C; EN-GJS-450-10U; EN-GJS-HB185; EN-JS1040; EN-JS1132; EN-JS-HB185	EN-GJS-450-18; EN-GJS-450-18C	EN-GJS-500-7; EN-GJS-500-7C; EN-GJS-500-7U; EN-GJS-HB200; EN-JS-1050; EN-JS-1082; EN-JS-2050	EN-GJS-600-3; EN-GJS-600-3C; EN-GJS-600-3U; EN-GJS-HB230; EN-JS1060; EN-JS1092; EN-JS2060	EN-GJS-700-2; EN-GJS-700-2C; EN-GJS-700-2U; EN GJS-HB265; EN-JS1070; EN-JS1102; EN-JS2070	EN-GJS-500-14; EN-GJS-500-14C	
	GOST (RUSSIA)	VCh 40	VCh 40; VCh 42-12	VCh 45		VCh 50; VCh 50-2; VCh 50-2-2	VCh 60; VCh 60-2	VCh 70; VCh 70-2; VCh 70-3		
	JIS (JAPAN)	FCD 400-18; FCD 400-18A	FCD 400-15; FCD 400-15A; FCD 400; FCD 40	FCD 450-10		FCD 500-7; FCD 500-7A; FCD 500; FCD 50	FCD 600-3; FCD 600-3A; FCD 600; FCD 60; FCD 550-7; FCD 550	FCD 700-2; FCD 700; FCD 70		
	SS (SWEDEN)		0717-02			0727-02	0732-03	0737-01		
	UNE (SPAIN)		FGE 38-17			FGE 50-7	FGE 60-2	FGE 70-2		
	UNI (ITALY)		GS 400/12			GS 500/7	GS 600/3	GS 700-2		
	IS (INDIA)		SG370/17	SG400/12		SG500/7	SG600/3	SG700/2		
	KS (REP. OF KOREA)		DC 40; GCD 42			GCD 50; GCD 500-7	GCD 600-3	GCD 700-2		
	GB/YB/JB/ SY/NB (PRC)	QT400-18	QT400-15	QT400-18L		QT500-7	QT600-3	QT700-2		

Material Designation in Accordance with Selected Standards

Standards		Material Group No.						
		18	18	18	19	19	19	20
	NF/AFNOR (FRANCE)			FGS 900-2	MN 35-10; A32-702 MN 350-10	MN 380-18; A32-702 MN 380-18		MP 60-3; A32-703 MP 60-3; Mn 550-4
	AISI/ASM/ ASTM/SAE/ UNS/AA (US)		F36200; A536 120-90-02; 120-90-02		A47-32510; A47 Class 32510; A47 Grade 32510; 32510; F22200	A47-35018, A47 Class 35018; A47 Grade 35018	A47-22010; A47 Class 22010; A47 Grade 22010; F22200	A220-50005; A220 Class 50005; A220 Grade 50005; A220-60004; A220 Class 60004; F24130
	BS (UK)		800/2; Grade 800/2	900/2; Grade 900/2	B 340/12; 310 B340/12		B 32-10; 6681 B 32-10	P 55-04; P 510/4
	DIN (GERMANY)		EN-GJS-800-2; EN-GJS-800-2C; EN-GJS-800-2U; EN-GJS-HB300; EN-JS1080; EN-JS1112; EN-JS2080; GGG-80		EN-GJMB-350-10; EN-JM 1130; GTS-35-10; GTS-35			EN-GJMB-550-4; EN-JM1160; GTS-55-04
	Werkstoff (GERMANY)	5.3110	0.7080; 5.3301	5.330	0.8135; 5.4101			0.8155; 5.4207
	EN (EUROPE)	EN-GJS-600-10; EN-GJS-600-10C	EN-GJS-800-2; EN-GJS-800-2C; EN-GJS-800-2U; EN-GJS-HB300; EN-JS1080; EN-JS1112; EN-JS2080	EN-GJS-900-2; EN-GJS-900-2U; EN-GJS-HB330; EN-JS1090; EN-JS1122; EN-JS2090	EN-GJMB-350-10; EN-JM 1130			EN-GJMB-550-4; EN-JM1160
	GOST (RUSSIA)		VCh 80; VCh 80-2; VCh 80-3	VCh 100; VCh 100-4	KCh 35-10	KCh 37-12	KCh 33-8	KCh 55-4
	JIS (JAPAN)		FCD 800-2; FCD 800		FCMB 35-10; FCMB 340		FCMB 310	FCMP 55-04; FCMP 540
	SS (SWEDEN)				0810; 0815-00			0856-00
	UNE (SPAIN)				GTS 35; 36114 Type A			Type C; 36116 Type C
	UNI (ITALY)		GS 800/2		B 35-10			P 55-04
	IS (INDIA)							
	KS (REP. OF KOREA)							
	GB/YB/JB/ SY/NB (PRC)				KTH350-10	KTH370-12	KTH330-08	KTZ550-04

Material Designation in Accordance with Selected Standards

Standards		Material Group No.							
		20	20	20	20	20	20	20	
	NF/AFNOR (FRANCE)		Mn 650-3	MP 70-2; A 32-703 MP 70-2; Mn 700-2	MP 50-5; A32-703 MP 50-5	MN 700-2			
	AISI/ASM/ ASTM/SAE/ UNS/AA (US)	A220-70003; A220 Class 70003; A220 Grade 70003; A220-480M3; A220 Class 480M3; A602-M5503; F24830	A220-70003; A220 Class 70003; A220 Grade 70003; A220-80002; A220 Class 80002; F25530	A220-70003; A220 Class 70003; A220 Grade 70003; F26230; F20004; F24830; A220-90001; A220-620M1	A220-45006; A220 Class 45006; A220 Grade 45006 A220-45008; A220-310M6; A220-310M8; F23130; F23131	A220-80002; A220 Class 80002; A220 Grade 80002; A602-M8501; F20005	A220-90001; A220 Class 90001; A220 Grade 90001	A220-60004; A220 Class 60004; A220 Grade 60004	A220-40010; A220 Class 40010; A220 Grade 40010
	BS (UK)		P 65-02; 6681 P 65-02; P 570/3	P 70-2; 6681 P 70-2; P 690/2	P 45-06; 6681 P 45-06				
	DIN (GERMANY)	EN-GJMB-600-3; EN-JM1170	EN-GJMB-650-2; EN-JM1180; GTS-65-02	EN-GJMB-700-2; EN-JM1190; GTS-70-02	EN-GJMD-450-6; EN-JM1140; GTS-45-06; GTS-45	EN-GJMB-800-1; EN-JM1200			
	Werkstoff (GERMANY)	5.421	0.8165; 5.4300	0.8170; 5.4301	0.8145; 5.4205	5.4302			
	EN (EUROPE)	EN-GJMB-600-3; EN-JM1170	EN-GJMB-650-2; EN-JM1180	EN-GJMB-700-2; EN-JM1190	EN-GJMD-450-6; EN-JM1140	EN-GJMB-800-1; EN-JM1200			
	GOST (RUSSIA)	KCh60-3	KCh 63-3; KCh 65-3	KCh 70-2	KCh 45-7	KCh 80-1.5			
	JIS (JAPAN)	FCMP 60-03	FCMP 65-02; FCMP 590	FCMP 70-02; FCMP 690	FCMP 45-06	FCMP 80-01; FCMP 70; FCMP 700			
	SS (SWEDEN)		0862-030	0862-03	0854-00				0852-00
	UNE (SPAIN)		Type B; 36116 Type B	36116 Type A	Type E; 36116 Type E				
	UNI (ITALY)		GMN 65; P 65-02	P 70-2; GMN 70	P 45-06				
	IS (INDIA)								
	KS (REP. OF KOREA)					PMC 490	PMC 590		
	GB/YB/JB/ SY/NB (PRC)		KTZ650-02	KTZ700-02	KTZ450-06	KTZ650-02	KTZ700-02	KTZ550-04	

Material Designation in Accordance with Selected Standards

Standards	Material Group No.			Material Group No.				
	20	20	20	21	21	21	21	22
 NF/AFNOR (FRANCE)	MB 400-5	MB 35-7	MB 380-12	A G0-6	A5	A4	A-G4.5MC	A-U4G
 AISI/ASM/ASTM/SAE/UNS/AA (US)				AA5005; AA5006; A95005; A95006; 5005; 5005A; 5006	AA1050; A91050; 1050; 1050A	AA1200; A91200; 1200; 1200A	AA5083; A95083; 5083	AA2017; A92017; 2017; 2017A
 BS (UK)	W 40-05	W 35-04		N41	1B	1C	N8	
 DIN (GERMANY)	EN-GJMW-400-5; GTW-40-05	EN-GJMW-350-4; GTW-35-04	GTW-S-38-12; EN-GJMW-360-12; EN-JM1020	AlMg1; AlMg1C	Al99,5; Al99,5	Al99,0; Al99,0; Al99	AlMg4,5Mn; AlMg4,5Mn	AlCu2,5Si(A); AlCu2,5Si(A); AlCuMg1
 Werkstoff (GERMANY)	0.8040; 5.4202	0.8035; 5.4200	0.8038; 5.4201	3.3315	3.0255	3.0205	3.355	3.1325; 3.1124
 EN (EUROPE)	EN-GJMW-400-5; EN-JM1030	EN-GJMW-350-4; EN-JM1010	EN-GJMW-360-12; EN-JM1020	AlMg1C; 5005A	Al99,5; Al99,5; 1050A	Al99,0; AL99,0; 1200	EN AW-5083; AlMg4,5Mn; AlMg4,5Mn	AlCu2,5Si(A); AlCu2,5Si(A); 2017A
 GOST (RUSSIA)				1510; AMg1	AD0	A0		V65
 JIS (JAPAN)	FCMW 40-05; FCMW 370	FCMW 35-04; FCMW 330	FCMW 38-12; FCMW 370	A5005		A1200	A5083	
 SS (SWEDEN)				144106	14407	144010	144140	
 UNE (SPAIN)	36113 Type A	36113 Type B		L-3350	L-3051	L-3001	L-3321	L-3120
 UNI (ITALY)	W 40-05	W 35-04		9005/1	9001/2	Al99,0	9005/5	
 IS (INDIA)				51000	19500	19000		24534
 KS (REP. OF KOREA)								
 GB/YB/JB/SY/NB (PRC)	KTB380-12	KTB350-04	KTB380-12	5005	1A50	1200; L50		2A11; LY11

Material Designation in Accordance with Selected Standards

Standards		Material Group No.							22
		22	22	22	22	22	22	22	
	NF/AFNOR (FRANCE)	A-SGM0.7		A-U5PbBi	A-Z5GU	A-U4G1	A-Z5G	A-GSUC	
	AISI/ASM/ASTM/SAE/UNS/AA (US)				AA7075; A97075; 7075	AA2024; A92024; 2024		AA6061; A96061; 6061	AA7010; A97010; 7010
	BS (UK)	H30		FC1	7075; L95; L96	2024; 2L97	H17	H20	5120 B; 5130 A
	DIN (GERMANY)	AlMgSi1	AlZnMgCu0.5; AlZnMgCu0.5	AlCu6BiPb; AlCuBiPb	AlZn5.5MgCu; AlZn5.5MgCu; AlZnMgCu1.5; AlZnMgCu1.5	AlCuMg2	AlZn4.5Mg1; AlZn4.5Mg1	AlMg1SiCu	AlZn6MgCu
	Werkstoff (GERMANY)	3.2315	3.4345	3.1655	3.4365; 3.4364	3.1355; 3.1354	3.4335	3.3211; 3.3214	3.4394
	EN (EUROPE)	AlSiMgMn; 6082; EN AW-6082	AlZnMgCu0.5; AlZnMgCu0.5; 7022	AlCu6BiPb; 2011	AlZn5.5MgCu; AlZn5.5MgCu; AW-7075; 7075	AlCu4Mg1; 2024	AlZn4.5Mg1; AlZn4.5Mg1; 7020	EN AW-6061; EN AW-AlMg1SiCu; AlMg1SiCu	EN AW-7010; AlZn6MgCu
	GOST (RUSSIA)	AD35			B95	D16		AD33	
	JIS (JAPAN)			A2011	A7075	A2024		A6061	
	SS (SWEDEN)	144312		144355			144425		
	UNE (SPAIN)	L-3453		L-3192	L-3710	L-3140	L-3741	L-3420	
	UNI (ITALY)	9006/4		9002/5	9007/2	9002/4; 3583	9007/1	9006/2	9007/4; P-AlZn6 2Mg2 3Cu 1.8Zr
	IS (INDIA)	64430			76528	24530	74530	65032	
	KS (REP. OF KOREA)				A7075P			A6061P	
	GB/YB/JB/SY/NB (PRC)		7022		7075	2A12	7020	6061	

Material Designation in Accordance with Selected Standards

Standards		Material Group No.								
		22	22	22	22	23	23	23	23	23
	NF/AFNOR (FRANCE)			A-U2GN; 2618A			A-S12U	A-G10S		
	AISI/ASM/ ASTM/SAE/ UNS/AA (US)	AA7050; A97050; 7050	AA6063; A96063; 6063	AA2618; A92618; A2618; 2618	AA7050; A97050; 7050			520.0; AA 520.0; A05200	222.0; AA 222.0; A02220	518.0; AA 518.0; A05180
	BS (UK)		H9	2618A; H16		LM5			LM12	
	DIN (GERMANY)	AlZn6CuMgZr	AlMg0.7Si	AlCu2Mg1.5Ni	AlZn6CuMgZr	G-AlMg5Si; GK-AlMg5Si; AlMg5Si; VDS 245	GD-AISI12(Cu); G-AISI12(Cu); AlSi12(Cu); VDS 231 D			G-AlMg9; GD-AlMg9; AlMg9; VDS 349
	Werkstoff (GERMANY)			3.192	3.4144	3.3261	3.2982			3.3292
	EN (EUROPE)	EN AW-7050; EN AW-AlZn6CuMgZr; AlZn6CuMgZr	EN AW-6063; AlMg0.7Si	EN AW-2618A; AlCu2Mg1.5Ni; 2618A	EN AW-7050; EN AW-AlZn6CuMgZr; AlZn6CuMgZr	EN AC-51400; EN AC-AlMg5Si; G-AlMg5Si; AlMg5Si	EN AC-47100; EN AC-AISI12C; G-AISI12Cu; AlSi12Cu; AlSi12Cu1(Fe)			EN AC-51200; EN AC-AlMg9; G-AlMg9; AlMg9
	GOST (RUSSIA)					AL13		A18		
	JIS (JAPAN)	A7050	A6063	A2618	A7050			AC7B		
	SS (SWEDEN)		144104			144163				
	UNE (SPAIN)		L-3441	L-3171; 2618A; Al-2CuMgNi				L-2310	L-2110	
	UNI (ITALY)			9002/6; 3578; P-AlCu2.3Mg1.5FeNi; 2618A			3048	3056	3041	
	IS (INDIA)						4685			
	KS (REP. OF KOREA)									
	GB/YB/JB/ SY/NB (PRC)			LD7	7050	ZL303		ZL301		















Material Designation in Accordance with Selected Standards

Standards		Material Group No.									
		23	23	23	23	23	23	23	23	24	24
	NF/AFNOR (FRANCE)	AU5NKZr		A-Z5GF	A-G6	A-S13			A-G3T		A-S9G
	AISI/ASM/ASTM/SAE/UNS/AA (US)	203.0; AA 203.0; A02030	ER4047; A94047	712.0; AA 712.0; A07120	514.0; 514.1; AA 514.0; AA 514.1; A05140; A05141	B413.0; AA B413.0; A24130; B213.0; AA 213.0; A22130		A444.0; AA A444.0; A14440		515.0; AA 515.0; A05150	
	BS (UK)		4047A; NG2			LM6			H20		
	DIN (GERMANY)	G-AlCu5Ni1,5; G-AlCu5Ni1.5	SG-AISI12	G-AlZn10Si8Mg; GK-AlZn10Si8Mg; AlZn10Si8Mg; VDS 108	G-AlMg5; GK-AlMg5; AlMg5; EN AC-51300; VDS 244	G-AISI12; GK-AISI12; GD-AISI12; AISI12	G-AISI11; GK-AISI11; AISI11		G-AlMg3; GK-AlMg3; GF-AlMg3; AlMg3; VDC 244	G-AlMg3Si; GK-AlMg3Si; GF-AlMg3Si; AlMg3Si; AlMg3Si1	G-AISI9Mg; GK-AISI9Mg; AISI9Mg
	Werkstoff (GERMANY)	3.1754	3.2585		3.3561	3.2581; 3.2582	3.2211		3.3541	3.3241	3.2373
	EN (EUROPE)		SG-AISI12; EL-AISI12	EN AC-71100; EN AC-AlZn10Si8Mg; G-AlZn10Si8Mg; AlZn10Si8Mg	EN AC-51300; EN AC-AlMg5; G-AlMg5; AlMg5	EN AC-44200; EN AC-AISI12; G-AISI12; GD-AISI12; AISI12	EN AC-44000; EN AC-AISI11; G-AISI11		EN AC-51100; EN AC-AlMg3; G-AlMg3; AlMg3	G-AlMg3Si1; AlMg3Si	G-AISI9Mg; AISI9Mg
	GOST (RUSSIA)				AL28; AMg5Mz;			AK7			AK9
	JIS (JAPAN)					AC3			ADC6		AC4A
	SS (SWEDEN)		144262			144261			144224		
	UNE (SPAIN)				L-2331	L-2520			L-2341		
	UNI (ITALY)			3602	3058	4514			3059		3051
	IS (INDIA)								53000		
	KS (REP. OF KOREA)										AC4A
	GB/YB/JB/SY/NB (PRC)		4047	ZL402	YI302	YL102			5754		ZL102



Material Designation in Accordance with Selected Standards

Standards		Material Group No.								
		24	24	24	24	24	24	24	24	
	NF/AFNOR (FRANCE)	A-S7G03	AU5GT		A-S9U3		A-S5UZ	A-S10UG	A-S10G	
	AISI/ASM/ASTM/SAE/UNS/AA (US)	A356.0; AA A356.0; A13560; A356.2; AA A356.2; A13562	204.0; AA 204.0; A02040	A333.0; AA A333.0; A13330	380.0; AA 380.0; A03800	365.0; AA 365.0; A03650	319.0; AA 319.0; A03190			
	BS (UK)	2L99			LM24		LM21			
	DIN (GERMANY)	G-AISI7Mg; GK-AISI7Mg; GF-AISI7Mg; AISI7Mg	G-AICu4TiMg; GK-AICu4TiMg; GF-AICu4TiMg; AICu4TiMg	G-AISI8Cu3; GK-AISI8Cu3	G-AISI9Cu3; GD-AISI9Cu3; AISI9Cu3; VDS 226	G-AISI10MnMg	G-AISI6Cu4; GK-AISI6Cu4; AISI6Cu4; VDS 225	G-AISI10MgCu; GK-AISI10MgCu; G-AISI10Mg(Cu); GK-AISI10Mg(Cu); AISI10MgCu; AISI10Mg(Cu)	G-AISI10Mg; GK-AISI10Mg; GD-AISI10Mg; AISI10Mg; VDS 239	G-AICu4Ti; AICu4Ti
	Werkstoff (GERMANY)	3.2371	3.1371	3.2161	3.2163		3.2151	3.2383	3.2381; 3.2385	3.1841
	EN (EUROPE)	G-AISI7Mg; AISI7Mg	EN AC-21000; EN AC-AICu4TiMg; G-AICu4TiMg	EN AC-AISI8Cu3; EN AC-AISI8Cu3; G-AISI8Cu3	EN AC-46200; EN AC-AISI8Cu3; G-AISI9Cu3; AISI8Cu3	EN AC-43500; EN AC-AISI10MnMg; G-AISI10MnMg	EN AC-45000; EN AC-AISI6Cu4; G-AISI6Cu4; AISI6Cu4		EN AC-43000; EN AC-AISI10Mg; G-AISI10Mg; AISI10Mg	EN AC-21100; EN AC-AICu4Ti; G-AICu4Ti; AICu4Ti
	GOST (RUSSIA)	AL9		AL13	AK8M3; AK8		AK5M			AL19
	JIS (JAPAN)	AC4CH	AC1B		AC4B		AC2B			
	SS (SWEDEN)			144163	144252		144230		144253	
	UNE (SPAIN)	L-2651	L-2140		L-2630		L-2620			
	UNI (ITALY)				3610		7369/4			
	IS (INDIA)									2280
	KS (REP. OF KOREA)									
	GB/YB/JB/SY/NB (PRC)	ZL101	ZL201		ZL105A		ZL107		YL104	ZL203

Material Designation in Accordance with Selected Standards

Standards		Material Group No.									
		24	25	25	25	26	26	26	26	26	26
	NF/AFNOR (FRANCE)						CuPb5Sn5Zn5; UE5; U-E 5 Pb 5 Z 5	CuSn7Pb6Zn4; UE7; U-E 7 Z 5 Pb 4	U-Pb15E8; U-Pb 15 E8	U-Pb10	CuZn36Pb3
	AISI/ASM/ASTM/SAE/UNS/AA (US)	A304	390.0; AA 390.0; A03900	393.0; AA 393.0; A03930		C83810	C83600	C93200	C93800	C93700	C36000
	BS (UK)		LM30	LM29	LM28	LG1	LG2	GC 493K	LB1	LB2	CZ124
	DIN (GERMANY)	G-AISI17Cu4Mg	G-AISI20CuMgNi; AISI20CuMgNi	G-AISI18Cu1MgNi; AISI18Cu1MgNi	CuSn3Zn8Pb5-C; G-CuSn2ZnPb	CuSn5Zn5Pb5-C; G-CuSn5ZnPb; Rg 5	CuSn7Zn4Pb7-C; G-CuSn7ZnPb; GC-CuSn7ZnPb; GZ-CuSn7ZnPb; Rg 7	CuSn7Pb15-C; G-CuPb15Sn; GC-CuPb15Sn; GZ-CuPb15Sn	CuSn10Pb10-C; G-CuPb10Sn; GC-CuPb10Sn; GZ-CuPb10Sn		CuZn36Pb3
	Werkstoff (GERMANY)				2.1098	2.1096; 2.1096.01	2.1090	2.1182	2.1176	2.0375	
	EN (EUROPE)		EN AB-48100; EN AC-48100; G-AISI17Cu4Mg; AISI17Cu4Mg			CuSn3Zn8Pb5-C	CuSn5Zn5Pb5-C	CuSn7Zn4Pb7-C	CuSn7Pb15-C; CC496K	CuSn10Pb10-C	CuZn36Pb3; CW603N
	GOST (RUSSIA)			AK21M2N2			Br05Ts5S5				
	JIS (JAPAN)		ADC14				H5111; H2203				C3600; C3601; C3602
	SS (SWEDEN)		4282				5204-15				
	UNE (SPAIN)								C-3300		
	UNI (ITALY)										12167
	IS (INDIA)										
	KS (REP. OF KOREA)										
	GB/YB/JB/SY/NB (PRC)						QSn4-0.3			ZCuPb10Sn10	HPb63-3















Material Designation in Accordance with Selected Standards

Standards		Material Group No.								
		26	26	27	27	27	27	27	27	27
	NF/AFNOR (FRANCE)	CuZn38Pb2		U-Z10; CuZn10	U-Z36N3; CuZn19Al6Y20	U-Z36; CuZn 36				U-Z15; CuZn15
	AISI/ASM/ ASTM/SAE/ UNS/AA (US)	C37000	C67300; J461; J463	C22000	C86200; SAE 430A	C27200	C27400	C86400	C46400	C23000; 85Cu-15Zn
	BS (UK)	CZ129		CZ101	HTB 1	CZ108	CZ108	HTB 1	CZ112	CZ102
	DIN (GERMANY)	CuZn38Pb2; CuZn38Pb1.5		CuZn10; Ms90	CuZn34Mn3Al2Fe1-C; G-CuZn34Al2; GK-CuZn34Al2; GZ-CuZn34Al2	CuZn36; Ms64	CuZn37; Ms63	CuZn35Mn2Al1Fe1-C; G-CuZn35Al1; GK-CuZn35Al1; GZ-CuZn35Al1; G-Ms60	CuZn38Sn1As; CuZn38Sn1	CuZn15 ; CuZn 15
	Werkstoff (GERMANY)	2.037		2.0230	2.0596	2.0335	2.0321	2.0592	2.0530	2.0240
	EN (EUROPE)	CuZn38Pb2; CW608N	CuZn35Mn3Pb2Si1	CuZn10; CW501L	CuZn34Mn3Al2Fe1-C; CC764S	CuZn36; CW507L	CuZn37; CW508L	CuZn35Mn2Al1Fe1-C; CC765S	CuZn38Sn1As; CW717R	CuZn15; CW502L
	GOST (RUSSIA)	LS59-1		L90	LTs23A; LTs23A6Zn3MTs2	L63	L63		LO60-1	
	JIS (JAPAN)	C3710		C2200	HBSC4; H5102/class 3; H5102/class 4		C2720	HBSC1; CAC301	C4640	C2300
	SS (SWEDEN)									5112-02; 5112-04; 5112-05
	UNE (SPAIN)									
	UNI (ITALY)			P-CuZn10; P-OT90		C 2700	P-CuZn37; P-OT63		P-CuZn39Sn1	
	IS (INDIA)									
	KS (REP. OF KOREA)									
	GB/YB/JB/ SY/NB (PRC)			H90	ZCuZn25Al6Fe3Mn3	H65	H63	ZCuZn35Al2Mn2Fe1	HSh60-1	H85















Material Designation in Accordance with Selected Standards

Standards		Material Group No.										
		27	27	27	27	27	27	27	28	28	28	28
	NF/AFNOR (FRANCE)	CuZn20	CuZn30					CuZn40	U-A10N; CuAl9Ni5Fe3	CuSn8	UE12P	CuAl10Fe5Ni5 Y70
	AISI/ASM/ ASTM/SAE/ UNS/AA (US)	C24000; 80Cu-20Zn	C26000; CA260	C27453			C85566	C28000	C63000	C90700	C90800; C91700	C95800; C95810
	BS (UK)	CZ103	CZ106					CZ109	CA 104	CT1	PB2	
	DIN (GERMANY)	CuZn20; CuZn 20; Ms80	CuZn30; CuZn 30					CuZn40	CuAl10Ni5Fe4; CuAl 10 Ni 5 Fe 4	CuSn10-C; G-CuSn 10; SnBz10	CuSn12-C; G-CuSn12; GZ-CuSn12; SnBz12, Gbz12	G-CuAl10Fe5Ni5-C; G-CuAl 10 Ni; NiAlBz-F60
	Werkstoff (GERMANY)	2.0250	2.0265					2.036	2.0966	2.1050	2.1052; 2.1052.01; 2.1052.04; 2.1052.03; 2.1056	2.0975
	EN (EUROPE)	CuZn20; CW503L	CuZn30; CW505L	CuZn38As; CW511L	CuZn36AlAsSb-B; CB771S	CuZn38AsSb-C; CC771S	CuZn40; CW509L	CuAl10Ni5Fe4; CW307G	CuSn10-C; CC480K	CuSn12-C; CC483K		CC333G
	GOST (RUSSIA)						L60		BrAD; BrAZhN10-4-4; N10-4-4			
	JIS (JAPAN)	C2400	C2600				C2801	C6301			CAC502C; PBC2C	CAC703C
	SS (SWEDEN)	5114-02; 5114-04; 5114-05										
	UNE (SPAIN)											
	UNI (ITALY)								P-CuAl10Ni5Fe5			
	IS (INDIA)											
	KS (REP. OF KOREA)											
	GB/YB/JB/ SY/NB (PRC)	H80	H70						QAI10-4-4			

Material Designation in Accordance with Selected Standards

Standards		Material Group No.										
		28	28	28	28	28	28	28	28	28	28	28
	NF/AFNOR (FRANCE)	Cu-B	U-Cr0.8Zr		Cl-c1; Cu-c2		U-C1Z; U-Cr0.8Zr	Cu-B	UA9	CuAl8	CuNi10Fe1Mn	CuZn16Si4-C
	AISI/ASM/ ASTM/SAE/ UNS/AA (US)	C11000	C81500	C10300	C10100; C10200	C86550	C18100; C18150	C11000; C12200	C95500	C61000	C70600; 90Cu-10Ni	C87500; C87400; C87800
	BS (UK)	C101	CC1-FF		C103; C110		CC102	C106			CN 102; CN102	ZCuZn16Si4
	DIN (GERMANY)	Cu-ETP; E-Cu57; E Cu 57	G-CuCrF 35	Cu-HCP; Cu-PHC; SE-Cu	Cu-OF; OF-Cu	G-CuZn40Fe; G-SoMsF30	CuCr1Zr; CuCrZr	Cu-DHP; E-Cu58; E Cu 58 SF-Cu	CuAl9Ni3Fe2	CuAl8; Cu Al 8	CuNi10Fe1Mn	G-CuZn15Si4; GD-CuZn15Si4; GK-CuZn15Si4
	Werkstoff (GERMANY)	2.0060	2.1292	2.0070	2.0040	2.0590	2.1293	2.0090	2.0971	2.0920	2.0872	2.0492; 2.0492-01; 2.0492-02; 2.0492-05
	EN (EUROPE)	Cu-ETP; E-Cu57; CW004A		Cu-HCP; CW020A; Cu-PHC; CW021A	Cu-OF; CW008A	G-CuZn40Fe	CuCr1Zr; CW106C	Cu-DHP; E-Cu58; CW024A		CuAl8	CW 352H; CuNi10Fe1Mn	CuZn16Si4-B; CuZn16Si4-C; CB761S; CC761S
	GOST (RUSSIA)	M1		LS60-2	M0b			M1f	BrA10Zn4N4L	BrA7	MNZhMtZ10-1-1	LTs16K4
	JIS (JAPAN)	C1100		C103	C1011; C1020			C1100; C1220			C7060; YCuNi-1	SzBC2; H5112/class 2; H5112/class 3
	SS (SWEDEN)										5667	
	UNE (SPAIN)	C11020			C-1120						CW 352H	
	UNI (ITALY)	Cu-DHP										
	IS (INDIA)											
	KS (REP. OF KOREA)											
	GB/YB/JB/ SY/NB (PRC)	T2			TU2		QCc0.6-0.4- 0.05	TP2		QA17	BFe10-1-1	

Material Designation in Accordance with Selected Standards

Standards		Material Group No.						Material Group No.				
		29	29	29	29	29	29	31	31	31	31	
	NF/AFNOR (FRANCE)							Z 20 NCS 33-16; Z 12 NCS 37-18; Z 12 NCS 35-16				
	AISI/ASM/ ASTM/SAE/ UNS/AA (US)							330; N08330	N08002; N08004; N08005; N08030			N08031
	BS (UK)							NA 17; INCOLOY alloy DS	330 C 11; 330 C 40; 331 C 40	NA 15		
	DIN (GERMANY)							X12NiCrSi35-16; X12NiCrSi36-16; X12 NiCrSi 36 16	GX40NiCrSi38-19 GX40NiCrSi38-18; G-X40 NiCrSi38 18	X2NiCrAlTi32-20; X2 NiCrAlTi 32 20	X1NiCrMoCu32-28-7; X1 NiCrMoCu 32 28 7	
	Werkstoff (GERMANY)							1.486	1.487	1.456		1.456
	EN (EUROPE)							X12NiCrSi35-16	GX40NiCrSi38-18	X2NiCrAlTi32-20	X1NiCrMoCu32-28-7	
	GOST (RUSSIA)	Capron; Nylon	Polymethylmetakrylat; orgsteklo; SOL; ST-1; 2-55	PVCh	Polystyrol	Teflon; PTFE; Ftoroplast-4	RST; RST-250; RST-275; RST-320; RST-410					
	JIS (JAPAN)							SUH 330	SCH 15; SCH 16	NCF 800		
	SS (SWEDEN)											
	UNE (SPAIN)							F.3313; X 12 CrNiSi 36-16				
	UNI (ITALY)								GX 50 NiCr 39 19			
	IS (INDIA)											
	KS (REP. OF KOREA)							STR 330	HRSC 15			
	GB/YB/JB/ SY/NB (PRC)							1Cr16Ni35		NS111		NS1404













Material Designation in Accordance with Selected Standards

Standards		Material Group No.							
		31	31	31	31	31	31	31	31
	NF/AFNOR (FRANCE)		Z 8 NC 33-21; Z 10 NC 32-21	Z 2 NCDU 31-27; Z 1 NCDU 31-27-03	Z 10 NC 32-21; Z 8 NC 33-21				
	AISI/ASM/ ASTM/SAE/ UNS/AA (US)		N08811	N08028	B 163; N08800; N08810; N08332; N08811				
	BS (UK)	NA 15	NA 15; NA 15 H		NA 15; NA 15 H				
	DIN (GERMANY)	X5NiCrAlTi31-20; X5 NiCrAlTi 31 20	X8NiCrAlTi32-21; X8 NiCrAlTi 32 21	X1NiCrMoCu31-27-4; X1 NiCrMoCu 31 27 4	X10NiCrAlTi32-21; X10NiCrAlTi32-20; X10 NiCrAlTi 32 20				
	Werkstoff (GERMANY)	1.496	1.496	1.456	1.488				
	EN (EUROPE)	X5NiCrAlTi31-20	X8NiCrAlTi32-21	X1NiCrMoCu31-27-4	X10NiCrAlTi32-21				
	GOST (RUSSIA)			EK77; ChN30MDB		08Ch15N25M3TYuB	06Ch16N15M3B; E1 847	08Ch15N24VTR; Ch15N24VT; EP 164	08Ch16N9M2
	JIS (JAPAN)	NCF 800 H; NCF 718			NCF 800; NCF 800 TB; NCF 800 TP				
	SS (SWEDEN)			2584					
	UNE (SPAIN)				F.3314; F.3545				
	UNI (ITALY)								
	IS (INDIA)								
	KS (REP. OF KOREA)								
	GB/YB/JB/ SY/NB (PRC)				NS112				















Material Designation in Accordance with Selected Standards

		Material Group No.									
Standards		31	31	31	31	32	32	32	32	32	32
	NF/AFNOR (FRANCE)		A54-301			Z 42 CNKDOWNb	Z 3 NCT 25; Z 6 NCTDV 25.15 B	Z 6 NCTDV 25-15 B			
	AISI/ASM/ ASTM/SAE/ UNS/AA (US)		K94610; AMS 7726; F15	K93600; K93601; B388; F1684	K93500; AMS 1-23011	S590; J 467	660; S66286; AMS 5731; AMS 5732; AMS 5737; AMS 5525		661; R30155	R30556	S41880; AMS 5508; AMS 5616; A565 Grade 615; J467
	BS (UK)			4J36			HR 51; HR 52; 286 S 31	HR 51			
	DIN (GERMANY)		NiCo 29 18; X3NiCo29-18	Ni36; Ni 36		X40CoCrNi20-20; X40 CoCrNi 20 20	X6NiCrTiMoVB25-15-2; X5NiCrTi26-15 X6 NiCrTiMoVB 25 15 2; X5 NiCrTi 26 15	X4NiCrTi25-15; X5NiCrTi26-15	X12CrCoNi21-20; X12 CrCoNi 21 20		
	Werkstoff (GERMANY)		1.398	1.391		1.4977	1.4980	1.4943; 1.4944	1.4971		
	EN (EUROPE)						X6NiCrTiMoVB25-15-2; X5NiCrTi26-15	X4NiCrTi25-15; X5NiCrTi26-15	X12CrCoNi21-20		
	GOST (RUSSIA)	20Ch12N2V2MF		36N; 36N-VI				36NChTyu			
	JIS (JAPAN)										
	SS (SWEDEN)							2570			
	UNE (SPAIN)										
	UNI (ITALY)										
	IS (INDIA)										
	KS (REP. OF KOREA)										
	GB/YB/JB/ SY/NB (PRC)						0Cr15Ni25Ti2MoA	GH2132	GH19		

Material Designation in Accordance with Selected Standards

Standards		Material Group No.							
		32	32	32	32	32	32	32	32
	NF/AFNOR (FRANCE)								
	AISI/ASM/ ASTM/SAE/ UNS/AA (US)	651; S63198; AMS 5579; AMS 5526	AMS 5725	662; S66220; AMS 5733	R30590; S-590			S38100; XM-15; A249 Grade TPXM-15	S66009
	BS (UK)								
	DIN (GERMANY)			X4NiCrMoTiMnSiB26-14-3-2			X5NiCrTiMoV26-15		
	Werkstoff (GERMANY)			1.464			1.3980		
	EN (EUROPE)								
	GOST (RUSSIA)					36NChTYu	08Ch15N25T2MFR	08Ch20N14S2; 08Ch20N14S2; EI 732	37Ch12N8G8MFB 45Ch14N14B2M
	JIS (JAPAN)								
	SS (SWEDEN)								
	UNE (SPAIN)								
	UNI (ITALY)								
	IS (INDIA)								
	KS (REP. OF KOREA)								
	GB/YB/JB/ SY/NB (PRC)								















Material Designation in Accordance with Selected Standards

Standards		Material Group No.										
		32	32	32	33	33	33	33	33	33	33	
	NF/AFNOR (FRANCE)				KC 20 WN	K 13 C 20 N16 Fe 15 D 7			NC 21 Fe DU		NC 20 T	NC 22 FeDNb
	AISI/ASM/ASTM/SAE/UNS/AA (US)			S66315	R30605; 670; 5537C; AMS 5759	R30003; R30008; F1058; F1058 Grade 1; F1058 Grade 2		R31233; B815; B818	Incoloy 825; N08825;	Hastelloy C-4; N06455	Nimonic 75; N06075; AMS 5715	Inconel 625; N06625; AMS 5666
	BS (UK)								NA 16		HR 5; HR 203-4	NA 21
	DIN (GERMANY)				CoCr20W15Ni	CoCr20Ni15Mo7; CoCr 20 Ni 15 Mo		CoCr26Ni9Mo5W; CoCr 26 Ni 9 Mo 5 W	NiCr21Mo	NiMo16Cr16Ti	NiCr20Ti	NiCr22Mo9Nb
	Werkstoff (GERMANY)				2.4964	2.471		2.468	2.4858	2.4610	2.4630; 2.4951	2.4856
	EN (EUROPE)				CoCr20W15Ni							
	GOST (RUSSIA)	40Ch15N7GF2MS; EI 388	ChN35VTYu; EI 787						ChN38VT			
	JIS (JAPAN)											
	SS (SWEDEN)											
	UNE (SPAIN)											
	UNI (ITALY)											
	IS (INDIA)											
	KS (REP. OF KOREA)											
	GB/YB/JB/SY/NB (PRC)				GH25				NS142	GH182		GH984













Material Designation in Accordance with Selected Standards

Standards		Material Group No.									
		33	33	33	33	33	33	33	33	33	33
	NF/AFNOR (FRANCE)	NC 30 Fe	NU 30	NC 22 FeD	NC 14 K 9 T 5 DWA	Z 8 NCDT 42		NC 19 KDT		NU 30	NC 16 FeT
	AISI/ASM/ASTM/SAE/UNS/AA (US)	Inconel 690; N06690	Monel 400; N04400	Hastelloy X; Inconel HX; N06002; 5390A; AMS 5754; AMS 5536	Inconel 617; N06617; AMS 5887	Nimonic 90; N07090; AMS 5829	Haynes 214; N07214	Rene 41; N07041; AMS 5712; AMS 5713; AMS 5800	Hastelloy B2; N10665	Monel R-405; N04405	Inconel 600; N06600; AMS 5665
	BS (UK)		NA 13; ANC 18	HR 6; HR 204		HR 2; HR202; HR 402; HR 501; HR 502; HR 503				NA 13	NA 14
	DIN (GERMANY)	NiCr29Fe	NiCu30Fe	NiCr30FeMo; NiCr22Fe18Mo; NiCr21Fe18Mo9	NiCr23Co12Mo	NiCr20Co18Ti; NiCr 20 Co 18 Ti	NiCr16Al	NiCr19Co11MoTi; NiCr 19 CoMo	NiMo28; EL-NiMo29; SG(UP)-NiMo27	NiCu30Fe	NiCr15Fe8; NiCr 15 Fe
	Werkstoff (GERMANY)	2.464	2.4360; 2.4361	2.4603; 2.4665	2.4663a	2.4632; 2.4969	2.4646	2.4973	2.4617; 2.4616; 2.4615	2.4360; 2.4361	2.4816
	EN (EUROPE)					NiCr20Co18Ti			NiMo28		NiCr15Fe8
	GOST (RUSSIA)										ChN78T
	JIS (JAPAN)								YNiMo-7		
	SS (SWEDEN)										
	UNE (SPAIN)										
	UNI (ITALY)										
	IS (INDIA)										
	KS (REP. OF KOREA)										
	GB/YB/ JB/ SY/NB (PRC)	NS315		GH22; GH334; GH536GH739; SG-5		GH4037		GH141	NS322		NS312















Material Designation in Accordance with Selected Standards

Standards		Material Group No.									
		33	33	33	33	33	33	33	33	33	33
	NF/AFNOR (FRANCE)	N C 23 FeA	NCK 20 D		NC 17 D			A54-301; Fe-Ni48	NW 11 AC		
	AISI/ASM/ASTM/SAE/UNS/AA (US)	Inconel 601; N06601	Nimonic 263; N07263; AMS 5872; AMS 5886	Hastelloy C-22; N06022	Hastelloy C-276; N10276	N06025	K94800; F 30	Nimonic PE 16	Haynes HR-120; N08120; B408; B409	Haynes HR-160; N12160	Udimet 520
	BS (UK)		HR 10; HR 206; HR 404					HR 55; HR 207			
	DIN (GERMANY)	NiCr23Fe15A; NiCr 23 Fe	NiCo20Cr20MoTi; NiCo 20 Cr 20 MoTi MoTi	NiCr21Mo14W	NiMo16Cr15W; NiMo 16 Cr 15 W	NiCr25FeAlY	Ni 48; RNi 12; RNi 8			NiCo29Cr28Si	
	Werkstoff (GERMANY)	2.4851	2.4650	2.4602	2.482	2.463	1.3922; 1.3926; 1.3927			2.488	
	EN (EUROPE)	NiCr23Fe15A	NiCo20Cr20MoTi			NiCr25FeAlY					
	GOST (RUSSIA)	ChN60Yu									
	JIS (JAPAN)			NW 6022		NCF 625					
	SS (SWEDEN)										
	UNE (SPAIN)										
	UNI (ITALY)										
	IS (INDIA)										
	KS (REP. OF KOREA)										
	GB/YB/JB/SY/NB (PRC)	NS313	GH163		NS334						













Material Designation in Accordance with Selected Standards

Standards		Material Group No.								34		
		33	33	34	34	34	34	34	34			
	NF/AFNOR (FRANCE)			KC 22 WN						NU 30 AT	NC 19 Fe Nb	NiFe25Cr20NbTi
	AISI/ASM/ASTM/SAE/UNS/AA (US)	Incoloy 840	N08020	R30188; AMS 5608; AMS 5772	R30816; S-816; B639; Grade 671 Cobalt			R30600		Monel K-500; N05500	Inconel 718; N07718; AMS 5596; AMS 5589	
	BS (UK)		GH 1015; NS 1403; NS 143							NA 18	HR 8	
	DIN (GERMANY)	X8CrNiAlTi20-20	NiCr20CuMo	CoCr22W14Ni	CoCr20Ni20W					NiCu30Al3Ti; NiCu 30 Al	NiCr19Nb5Mo3; NiCr 19 NbMo; NiCr19Fe19Nb5Mo3	NiFe25Cr20NbTi; NiFe 25 Cr 20 NbTi
	Werkstoff (GERMANY)	1.485	2.466	2.4964	2.4989			2.478		2.438	2.467	2.496
	EN (EUROPE)		NiCr20CuMo	CoCr22W14Ni	CoCr20Ni20W					NiCu30Al3Ti	NiCr19Nb5Mo3	NiFe25Cr20NbTi
	GOST (RUSSIA)		ChN28VMAB		Altemp S-816							
	JIS (JAPAN)											
	SS (SWEDEN)											
	UNE (SPAIN)											
	UNI (ITALY)											
	IS (INDIA)											
	KS (REP. OF KOREA)											
	GB/YB/ JB/ SY/NB (PRC)			GH25		GH4169	GH901; GH109	GH146				















Material Designation in Accordance with Selected Standards

Standards		Material Group No.									
		34	34	34	34	34	34	34	34	34	34
	NF/AFNOR (FRANCE)		Z 8 NCDT 42	NCK 19 DAT	NC 20 TA			NC 20 K 14		NC 19 KDT	NC 14 K8
	AISI/ASM/ ASTM/SAE/ UNS/AA (US)	Incoloy 925; N09925	Nimonic 901; N09901; AMS 5660; AMS 5661	Udimet 500; N07500; AISI 684	Nimonic 80A; N07080	MAR-M 246	Inconel 722; N07722; AMS 5411	Waspaloy; N07001; AISI 685; AMS 5704; AMS 5706; AMS 5708; AMS 5544		Rene 41; N07041; AMS 5712; AMS 5713; AMS 5800	Rene 95
	BS (UK)				HR 401; HR 601						
	DIN (GERMANY)		NiFe35Cr14MoTi; NiCr13Mo6Ti3; NiCr 13 Mo 6 Ti 3	NiCr18Co18MoAlTi	NiCr20TiAl; NiCr 20 TiAl	NiCr23Mo16Cu; NiCr 23 Mo 16 Cu		NiCr20Co13Mo4Ti3AL; NiCr 19 Co 14 Mo 4 Ti		NiCr19Co11MoTi; NiCr 19 CoMo	
	Werkstoff (GERMANY)		2.4662	2.4983	2.4631; 2.4952	2.4675		2.4654		2.4973	
	EN (EUROPE)			NiCr18Co18MoAlTi	NiCr20TiAl	NiCr23Mo16Cu		NiCr20Co13Mo4Ti3AL			
	GOST (RUSSIA)				ChN77TYuR; ChN56VMTYu				ChN75VMYU; Ei 827		
	JIS (JAPAN)				NCF 80 A						
	SS (SWEDEN)										
	UNE (SPAIN)										
	UNI (ITALY)										
	IS (INDIA)										
	KS (REP. OF KOREA)										
	GB/YB/JB/ SY/NB (PRC)				GH80A		GH141	GH738			















Material Designation in Accordance with Selected Standards

Standards		Material Group No.									
		34	34	34	34	34	34	34	34	34	
	NF/AFNOR (FRANCE)					NK 20 CDA; NCK 20 Atv	NCK 15 ATD	NC 19 KDu/v	NC 16 FeTNb		Z 3 NK 28; Z 3 NK 38
	AISI/ASM/ ASTM/SAE/ UNS/AA (US)	N06230; AMS 5891; AMS 5878			Udimet 700; 687; AMS 5846; J467; GE C50T67	Nimonic 105; N13021; C565	Nimonic 115; N06115; AMS 5666	Nimonic PK 33	Inconel X-750; N07750; AMS 5542; AMS 5582; AMS 5670; AMS 5667	Astrolloy; N13017; AMS 5851; AMS 5852; AMS 5882	Incoloy 903; N19903; AMS 5803; AMS 5884; AMS 5892; AMS 5893
	BS (UK)					HR 3	HR 4				
	DIN (GERMANY)	NiCr22W14Mo				NiCo20Cr15MoAlTi; NiCo 20 Cr 5 MoAlTi	NiCo15Cr15MoAlTi; NiCo 15 Cr 5 MoAlTi		NiCr15Fe7TiAl; NiCr15Fe7Ti2Al		
	Werkstoff (GERMANY)	2.473				2.463	2.464		2.467		
	EN (EUROPE)								NiCr15Fe7TiAl; NiCr15Fe7Ti2Al		
	GOST (RUSSIA)		ChN72MVKYu	ChN60MVTYu							
	JIS (JAPAN)										
	SS (SWEDEN)										
	UNE (SPAIN)										
	UNI (ITALY)										
	IS (INDIA)										
	KS (REP. OF KOREA)										
	GB/YB/JB/ SY/NB (PRC)										















Material Designation in Accordance with Selected Standards

Standards		Material Group No.								
		34	34	35	35	35	35	35	35	35
	NF/AFNOR (FRANCE)				ND 30 M		NK 15 CAT		NC 13 AD	
	AISI/ASM/ASTM/SAE/UNS/AA (US)		Inconel 740H; N07740	5388C; N30002; CW-12MW;	N7M; N-7M; N30007	N12MV; N-12MV; N30012	Nimocast PK24; N13100; AMS 5397	Jethete M-252; N07252; AMS 5551	Nimocast 713; N07713; AMS 5391; Inconel 713LC	M-35-1; N214135
	BS (UK)						HC 204		HC 203	
	DIN (GERMANY)	NoCr25Co20TiMo		G-NiM16CrW	G-NiMo28	G-NiMo30	G-NiCo15Cr10AlTiMo	G-NiCr19Co; G-NiCr 19 Co	G-NiCr13Al6MoNb	G-NiCu40Nb
	Werkstoff (GERMANY)	2.488		2.4883	2.4685	2.4882; 9.4810; 2.4810/9.4810	2.4674	2.4916	2.467	2.4365; 2.4365/9.4365
	EN (EUROPE)	NoCr25Co20TiMo								
	GOST (RUSSIA)									
	JIS (JAPAN)									NiCuC
	SS (SWEDEN)									
	UNE (SPAIN)									
	UNI (ITALY)									
	IS (INDIA)									
	KS (REP. OF KOREA)									
	GB/YB/JB/SY/NB (PRC)									













Material Designation in Accordance with Selected Standards

Standards		Material Group No.										
		35	35	35	35	35	35	35	35	35	35	
	NF/AFNOR (FRANCE)			NC14 K9 T5 DWA								
	AISI/ASM/ASTM/SAE/UNS/AA (US)		Rene 77	Rene 80					MAR-M 247	MAR-M 421	MAR-M 432	Rene 125
	BS (UK)											
	DIN (GERMANY)	G-NiCr28W			G-NiCr15					G-NiCo10W10CrAINb		
	Werkstoff (GERMANY)	2.488			2.482					2.468		
	EN (EUROPE)	G-NiCr28W			G-NiCr15							
	GOST (RUSSIA)					ChN62MVKYuL	ChN65VMTYuL	ChN67VMTYuL				
	JIS (JAPAN)											
	SS (SWEDEN)											
	UNE (SPAIN)											
	UNI (ITALY)											
	IS (INDIA)											
	KS (REP. OF KOREA)											
	GB/YB/JB/SY/NB (PRC)											





Material Designation in Accordance with Selected Standards

		Material Group No.								
Standards		35	35	35	35	35	35	36	36	36
	NF/AFNOR (FRANCE)			KD 27 DN	KC 25 NW; KC 25 N 10 W 7 Fe			T-35	T-40	T-50
	AISI/ASM/ ASTM/SAE/ UNS/AA (US)	Rene 220C	Udimet 700B	F75; AMS 5385D	A567; AMS 5382E; Cobalt Alloy 31; Cobalt #31			R50250; Titanium Grade 1; ASTM GR. 1	R50400; Titanium Grade 2; AMS 4902; AMS 4941; ASTM Gr. 2	R50500; R50550; Titanium Grade 3; AMS 4900
	BS (UK)			ANC 14	ANC 13; 3146.2			TA1	TA2; TA3; TA4; TA5	DTD 5023, DTD 5273
	DIN (GERMANY)			CoCr28MoNi	CoCr25NiW	G-CoCr28	G-CoCr28Nb	Ti 1; Ti 99.8; Titan Grade 1	Ti 2; Ti 99.7	Ti 3; Ti 99.6; Titan Grade 3
	Werkstoff (GERMANY)			2.498	2.497	2.478	2.478	3.7024; 3.7025	3.7034; 3.7035; 3.7036	3.7055; 3.7056
	EN (EUROPE)					G-CoCr28		Ti 99.8	Ti 99.7	Ti 99.6
	GOST (RUSSIA)							VT1-00	VT1-0	
	JIS (JAPAN)							Class 2; Gr-1	Class 2; Gr-2	Class 3; Gr-3
	SS (SWEDEN)									
	UNE (SPAIN)							Ti-PO1	Ti-PO2; 38-711L-7001; 38-712L-7002	
	UNI (ITALY)							Ti1-Type 1	Ti1-Type 2	Ti1-Type 3
	IS (INDIA)									
	KS (REP. OF KOREA)									
	GB/YB/JB/ SY/NB (PRC)							TA0	TA1	TA2

Material Designation in Accordance with Selected Standards

Standards		Material Group No.							
		36	36	36	36	36	36	36	36
	NF/AFNOR (FRANCE)	T-60							
	AISI/ASM/ASTM/SAE/UNS/AA (US)	R50700; Titanium Grade 4; AMS 4901; AMS 4921	R52400; Titanium Grade 7; Ti-0.15Pd	R52250; Titanium Grade 11; Ti-0.15Pd	R52402; Titanium Grade 16; Ti-0.05Pd	R52252; Titanium Grade 17; Ti-0.05Pd	R52404; Titanium Grade 26; Ti-0.1Ru	R52254; Titanium Grade 27; Ti-0.1Ru	R53400; Titanium Grade 12; Ti-0.3Mo-0.8Ni; AMS 4902
	BS (UK)	TA7; TA8; TA9							
	DIN (GERMANY)	Ti 4; Ti 99.5; Titan Grade 4							TiNi0.8Mo0.3
	Werkstoff (GERMANY)	3.7064; 3.7065; 3.7066	3.724	3.723					3.711
	EN (EUROPE)	Ti 99.5							TiNi0.8Mo0.3
	GOST (RUSSIA)								
	JIS (JAPAN)	Class 4; Gr-4	Class 13; Gr-13	Class 13; Gr-13					
	SS (SWEDEN)								
	UNE (SPAIN)	38-714L-7004	38-715L-7021	38-715L-7021					
	UNI (ITALY)	Ti1-Type 4	Ti2Pd-Type 7	Ti2Pd-Type 7					
	IS (INDIA)								
	KS (REP. OF KOREA)								
	GB/YB/JB/SY/NB (PRC)	TA3	TA9						

Material Designation in Accordance with Selected Standards

Standards		Material Group No.						
		37	37	37	37	37	37	37
	NF/AFNOR (FRANCE)	TA6V; T-A6V; Ti-P.63	TA6ZR4DE; T-A6ZR4DE		TA6V6E2; T-A6V6E2		TU2; T-U2	TA4DE; T-A4DE
	AISI/ASM/ ASTM/SAE/ UNS/AA (US)	R56400; Titanium Grade 5; Ti-6Al-4V; AMS 4911; AMS 4928	R54620; Titanium Grade 6Al-2Sn-4Zr-2Mo; 6Al-2Sn-4Zr-2Mo; AMS 4975; AMS 4976; AMS 4919	R54790; Ti-679; AMS 4974	R56620; Titanium Grade 6Al-6V-2Sn; Ti-6Al-6V-2Sn; AMS 4918; AMS 4936; AMS 4971; AMS 4978	R56320; Titanium Grade 9; Ti-3Al-2.5V; AMS 4943; AMS 4944		
	BS (UK)	TA10; TA11; TA12; TA13; TA 28; TA56; Ti-Al-V	TA18; TA19; TA20; TA25; TA26; TA27	TA18; TA19; TA20; TA25; TA26; TA27			TA21; TA22; TA23; TA24	TA45; TA46; TA47; TA48; TA49; TA50; TA51; TA57
	DIN (GERMANY)	Ti6Al4V; Titan Grade 5; Titan 6 Al 4V	TiAl6Sn2Zr4Mo2		Ti-6Al-2Sn-4Zr-6Mo	Ti6Al2.5V; Titan Grade 9; Titan 3Al 2,5V	TiCu2	Ti4Al4Mo2Sn; TiAl4Mo4Sn4Si0.5
	Werkstoff (GERMANY)	3.7165; 3.7164	3.7145; 3.7144		3.7175; 3.7174	3.7195; 3.7194	3.712	3.7185; 3.7184
	EN (EUROPE)	Ti6Al4V	TiAl6Sn2Zr4Mo2		Ti-6Al-6V-2Sn	Ti6Al2.5V		
	GOST (RUSSIA)	VT6; VT6L	VT25			PT-3V		
	JIS (JAPAN)	Class 6 0; Gr 6 0; SAT-64; TAB 6400E; TAF 6400				Class 6 1; Gr 6 1		
	SS (SWEDEN)							
	UNE (SPAIN)	Ti-P63; 38-723L-7301			38-725L-7303		Ti-P11	Ti-P68
	UNI (ITALY)	TiAl6V4-Type 5				TiAl3V2.5-Type 9		
	IS (INDIA)							
	KS (REP. OF KOREA)							
	GB/YB/JB/ SY/NB (PRC)				TC4	TC2		

Material Designation in Accordance with Selected Standards

Standards		Material Group No.							
		37	37	37	37	37	37	37	
	NF/AFNOR (FRANCE)	TA5E; T-A5E; Ti-P.65				TA6VE; T-A6VE	TA4D3V; T-A4D3V		TA8DV; T-A8DV
	AISI/ASM/ ASTM/SAE/ UNS/AA (US)	R54520; Titanium Grade 6; Ti-5Al-2.5Sn; Gr6; AMS 4910; AMS 4926	R54521; Titanium Grade Ti-5Al-2.5Sn-ELI; Ti-5Al-2.5Sn-ELI; AMS 4909; AMS 4924	R56410; Titanium Grade Ti-10V-2Fe-3Al	R56401; R56407; Titanium Grade 23; Ti-6Al-4V-ELI; AMS 4907; AMS 4930; AMS 4956	Ti-4Al-3Mo-1V		R54810; Titanium Grade Ti-8Al-1Mo-1V; Ti-8Al-1Mo-1V; AMS 4915; AMS 4916; AMS 4972; AMS 4973	
	BS (UK)	TA14; TA17	TA32		TA11			TA40	
	DIN (GERMANY)	TiAl5Sn2.5; TiAl 5 Sn 22; Titan 5Al2.5Sn; Ti6Al2,5Sn	TiAl5Sn2.5 ELI		Ti6Al4V ELI				
	Werkstoff (GERMANY)	3.7115.1; 3.7115; 3.7114							
	EN (EUROPE)	TiAl5Sn2.5							
	GOST (RUSSIA)	VT5-1	VT5-1		VT6S	VT14	VT22		
	JIS (JAPAN)	SAT-525			Class 6 1; Gr 6 1				
	SS (SWEDEN)								
	UNE (SPAIN)	38-716L-7101							
	UNI (ITALY)				TiAl6V4ELI-Type 5.1				
	IS (INDIA)								
	KS (REP. OF KOREA)								
	GB/YB/JB/ SY/NB (PRC)	TA7							











Material Designation in Accordance with Selected Standards

Standards		Material Group No.					
		37	37	37	37	37	37
	NF/AFNOR (FRANCE)						
	AISI/ASM/ ASTM/SAE/ UNS/AA (US)	R56322; Titanium Grade 18; Ti-3Al-2.5V-0.05Pd; Ti-Pd18; F18	R56323; Titanium Grade 28; Ti-3Al-2.5V-0.1Ru	R54250; Titanium Grade 38; Ti-4Al-2.5V; AMS 6946B	R56260; Titanium Grade 6Al-2Sn-4Zr-6Mo; Ti-6Al-2Sn-4Zr-6Mo; AMS 4981B	R58650; Titanium Grade Ti-5Al-2Sn-2Zr-4Cr-4Mo; AMS 4995; AMS 4997	Ti-6Al-2Sn-2Zr-2Mo-2Cr-0.15Si; AMS 4898
	BS (UK)						
	DIN (GERMANY)				Ti6Al2Sn4Zr6Mo	Ti5Al2Sn2Zr4Mo4Cr	
	Werkstoff (GERMANY)						
	EN (EUROPE)				Ti6Al2Sn4Zr6Mo	Ti5Al2Sn2Zr4Mo4Cr	
	GOST (RUSSIA)						
	JIS (JAPAN)		TAT 3250 Class 61				
	SS (SWEDEN)						
	UNE (SPAIN)						
	UNI (ITALY)						
	IS (INDIA)						
	KS (REP. OF KOREA)						
	GB/YB/JB/ SY/NB (PRC)						

Material Designation in Accordance with Selected Standards

Standards		Material Group No.							
		37	37	37	37	37	37	37	37
	NF/AFNOR (FRANCE)								
	AISI/ASM/ ASTM/SAE/ UNS/AA (US)	Ti-4.5Al-3V-2Mo-2Fe; AMS 4899	R56700; Titanium Grade Ti-6Al-7Nb; F1295			R56410; Ti-10V-2Fe-3Al; AMS 4983; AMS 4984; AMS 4986; AMS 4987	R58010; Ti-13V-11Cr-3Al; AMS 4917; AMS 4959; B120VCA; B-1; 3Al-13V-11Cr	R58030; Titanium Grade 10; Ti-11.5Mo-6Zr-4.5Sn; AMS 4977; AMS 4980	R58153; Ti-15V-3Cr-3Al-3Sn; AMS 4914
	BS (UK)						TA3	TA5	
	DIN (GERMANY)								
	Werkstoff (GERMANY)								
	EN (EUROPE)				Ti5Al5V5Mo3Cr				
	GOST (RUSSIA)			OT4-1	VST 5553				
	JIS (JAPAN)			ST-A90					
	SS (SWEDEN)								
	UNE (SPAIN)						38-729L-7701		
	UNI (ITALY)								
	IS (INDIA)								
	KS (REP. OF KOREA)								
	GB/YB/JB/ SY/NB (PRC)								

Material Designation in Accordance with Selected Standards

Standards		Material Group No.						Material Group No.	
		37	37	37	37	37	37	38	
	NF/AFNOR (FRANCE)							C 105 E 2 U; Y1 105; C105E2U	
	AISI/ASM/ ASTM/SAE/ UNS/AA (US)	R58210; Titanium Grade 21; Ti-15Mo-2.7Nb-3Al-0.2Si; B265	R58640; Titanium Grade 19; Ti-3Al-8V-6Cr-4Mo-4Zr	R58645; Titanium Grade 20; Ti-3Al-8V-6Cr-4Mo-4Zr	R58820; Titanium Grade 8Mo-8V-2Fe-3Al; Ti-8Mo-8V-2Fe-3Al			W110; T72301	
	BS (UK)		TA38						
	DIN (GERMANY)							C105U; C 105 W 1; C 105 U	
	Werkstoff (GERMANY)							1.1545	
	EN (EUROPE)							C105U	
	GOST (RUSSIA)					VT15	VT15-1	VT19	U10A-1; U10A-2; U11-1
	JIS (JAPAN)								SK 105; SK 3; TC 105
	SS (SWEDEN)								1880
	UNE (SPAIN)								F.515; F.516
	UNI (ITALY)								C 100 KU
	IS (INDIA)								
	KS (REP. OF KOREA)								STC 105; STC 3
	GB/YB/JB/ SY/NB (PRC)								T10

Material Designation in Accordance with Selected Standards

Standards		Material Group No.									
		38	38	38	38	38	38	38	38	38	38
	NF/AFNOR (FRANCE)	35 NCD 14	C 105 E 2 UV 1; Y1 105 V; 100 V 2	50CrV4RR; 50 CV 4; 51 CV 4	34 CD 4		X40Cr14; Z 40 C 14			Z 30 WCV 9	
	AISI/ASM/ ASTM/SAE/ UNS/AA (US)		W210; T72302	6145; 6150; 6150 H; G61500; H61500	P20; T51620			300M; 4340M; K44220		H21; T20821	S7; T41907
	BS (UK)	832 M 31	BW 2	735 A 50; 735 A 51; 735 H 51; 735 M 50; En 47	708 A 37					BH 21	
	DIN (GERMANY)	32NiCrMo14-5; 32 NiCrMo 14-5	100V1; 100 V 1	51CrV4; 50CrV4; 50 CrV 4	35CrMo4; 35 CrMo 4	26MnCr6-3	X40Cr14; X 42 Cr 13	41SiNiCrMoV7-6		X30WCrV9-3; X30WCrV9 3	50CrMoV13-4; 50 CrMoV 13 4; 50CrMoV13-15
	Werkstoff (GERMANY)	1.6746	1.2833	1.8159	1.2330	1.8721	1.2083; 1.2083 ESR	1.6928		1.2581	
	EN (EUROPE)	32NiCrMo14-5	100V1	51CrV4	35CrMo4	26MnCr6-3	X40Cr14	S 155		X30WCrV9-3; X30WCrV9 3	50CrMoV13-15
	GOST (RUSSIA)			50ChFA; 50ChGFA					30ChGSA	3Ch2W8F	
	JIS (JAPAN)		SKS 43	SUP 10; SUP 10-CSP; SUP 10 M			SUS 420 J 2			SKD 5	
	SS (SWEDEN)			2230	2234		2314				
	UNE (SPAIN)	F.1262-32 NiCrMo 12		F.143; F.143.A; 51 CrV 4; F.1430			F.5263; X 40 Cr 13			F.5323; X 30 WCV 9	1.2357; 1.2355
	UNI (ITALY)		102 V 2 KU	50 CrV 4	35 CrMo 4		X 41 Cr 13 KU			X 30 WCV 9 3 KU	
	IS (INDIA)										
	KS (REP. OF KOREA)		SPS 4	SPS 10	SCM 435TK		STS 420J2				
	GB/YB/JB/ SY/NB (PRC)		T9; V	50CrVA	3CrMo		3Cr13				

Material Designation in Accordance with Selected Standards

Standards		Material Group No.										
		38	38	38	38	38	38	38	38	38	39	
	NF/AFNOR (FRANCE)			Z 40 C 13		55WC20; 55 WC 20	Z 2 CN 18-10 M					X 160 CrMoV 12; Z 160 CDV 12
	AISI/ASM/ ASTM/SAE/ UNS/AA (US)	A9; T30109	S6; T41906	420 C	414; S41400; AMS 5615	S1; T41901	K92710	K92890; AMS 6512	K93120; AMS 6514	K93540; AMS 6515		D2; T30402
	BS (UK)			420 S 45		BS 1		BS S162				BD 2
	DIN (GERMANY)			X39Cr13; X 38 Cr 13		60WCrV8; 60 WCrV 7	X2NiCoMo18-8-5	X2NiCoMo18-9-5; X2NiCoMo18-8-5	X2NiCoMo18-8-5	X2NiCoMo18-12-; X2NiCoMoTi18-12-4		X153CrMoV12; X155CrVMo12-1; X155 CrVMo 12 1
	Werkstoff (GERMANY)			1.4031		1.2550	1.6359	1.6358; 1.6359	1.6354; 1.6359	1.6355; 1.6356		1.238
	EN (EUROPE)			X39Cr13		60WCrV8	X2NiCoMo18-8-5	X2NiCoMo18-8-5	X2NiCoMo18-8-5			X153CrMoV12
	GOST (RUSSIA)			40Ch13		6ChV2S; 5ChV2S						
	JIS (JAPAN)											SKD 10; SKD 11
	SS (SWEDEN)											2310
	UNE (SPAIN)											F.520.A
	UNI (ITALY)			X 40 Cr 14		55 WCrV 8 KU						X 155 CrVMo 12 1 KU
	IS (INDIA)											
	KS (REP. OF KOREA)											
	GB/YB/JB/ SY/NB (PRC)											Cr12MoV







Material Designation in Accordance with Selected Standards

Standards		Material Group No.									
		39	39	39	39	39	39	39	39	39	39
	NF/AFNOR (FRANCE)	X200Cr12; Z 200 C 12	100Cr6RR; 100 C 6; 100Cr6; Y 100 C 6	90 MnV 8; 90 MV 8	X 40 CrMoV 5; Z 40 CDV 5		Z 100 CD 17 Cl; Z 100 CD 17			100 C 3	55 NCDV 7; 55 NiCrMoV7
	AISI/ASM/ ASTM/SAE/ UNS/AA (US)	D3; T30403	L3; T61203	O2; T31502	H13; T20813		440C; S44004; S44025	440A; S44002; J91606		L2; T61202	L6; T61206
	BS (UK)	BD 3	BL 3; BL3	BO 2; BO2	BH 13						
	DIN (GERMANY)	X210Cr12; X 210 Cr 12	102Cr6; 102 Cr 6; 100 Cr 6	90MnCrV8; 90 MnCrV 8	X40CrMoV5-1; X40 CrMoV 5 1		X105CrMo17; X105 CrMo 17	X70CrMo15; X 65 CrMo 14	62SiMnCr4; 62 SiMnCr 4	115CrV3; 115 CrV 3	55NiCrMoV7; 56 NiCrMoV 7
	Werkstoff (GERMANY)	1.2080	1.2067	1.284	1.2344		1.4125	1.411	1.2101	1.2210	1.2714
	EN (EUROPE)	X210Cr12	102Cr6	90MnCrV8	X40CrMoV5-1		X105CrMo17	X70CrMo15		115CrV3	55NiCrMoV7
	GOST (RUSSIA)	Ch12	Ch		4Ch5MF1S		95Ch18; 110Ch18M-SchD				5ChGNM
	JIS (JAPAN)	SKD 1	SUJ 2		SKD 61		SUS 440 C				SKT 4
	SS (SWEDEN)				2242						
	UNE (SPAIN)	F.521; F.5212; X 210 Cr 12	F.5230; 100 Cr 6	90 MnCrV 8; F.5229	F.5318; X 40 CrMoV 5					F.520.L; F.5125	F.520.B; 55 NiCrMoV 7; F.5307
	UNI (ITALY)	X 205 Cr 12 KU	102 Cr 6 KU	90 MoVCr 8 KU	X 40 CrMoV 5 1 1 KU					107 CrV 3 KU	55 NiCrMoV 7 KU; 56 NiCrMoV 7 KU
	IS (INDIA)	T215Cr12									
	KS (REP. OF KOREA)	STR 3	STB 2		STD 61	STF 4					
	GB/YB/JB/ SY/NB (PRC)	Cr12	Cr2	9Mn2V	40CrMoV5	5CrNiMo	9Cr18				















Material Designation in Accordance with Selected Standards

Standards		Material Group No.												
		39	39	39	39	39	39	39	39	39	39	39		
	NF/AFNOR (FRANCE)										C 105 E 2 U; Y1 105; C105E2U	X200Cr12; Z 200 C 12	HS 2-8-1; Z 85 DCWV 08-04-02-01	18-0-1; HS 18-0-1; Z 80 WCV 18-04-01
	AISI/ASM/ ASTM/SAE/ UNS/AA (US)	S2; T41902	S5; T41905	D7; T30407	A6; T30106	A8; T30108	440F; S44020	K93540; AMS 6515		W1; T72301	W110; T72301	D3; T30403	M1; H41; T11301; T20841	T1; T12001
	BS (UK)									BW 18		BD 3	BM 1	BT 1
	DIN (GERMANY)							X2NiCoMo18-12; X2NiCoMoTi18-12-4		C80W2; C 80 W2	C105U; C 105 W 1; C 105 U	X210Cr12; X 210 Cr 12	HS2-9-1; S 2-9-1	HS18-0-1; S 18-0-1
	Werkstoff (GERMANY)							1.6355; 1.6356		1.1625	1.1545	1.2080	1.3346	1.336
	EN (EUROPE)									C80W2	C105U	X210Cr12	HS2-9-1	HS18-0-1
	GOST (RUSSIA)									U8-1	U10A-1; U10A-2; U11-1	Ch12		R18
	JIS (JAPAN)									SK 75; SK 85; SK 85 M; SK 5; SK 5 M; SK 6	SK 105; SK 3; TC 105	SKD 1		SKH 2
	SS (SWEDEN)										1880			2750
	UNE (SPAIN)									F.520.U; F.5107; C 80	F.515; F.516	F.521; F.5212; X 210 Cr 12		F.5520; HS 18-0-1
	UNI (ITALY)										C 100 KU	X 205 Cr 12 KU		HS 18-0-1
	IS (INDIA)													
	KS (REP. OF KOREA)										STC 105; STC 3			
	GB/YB/JB/ SY/NB (PRC)									T7	T10			W18Cr4V















Material Designation in Accordance with Selected Standards

Standards		Material Group No.											
		39	39	39	39	39	39	39	39	39	40		
	NF/AFNOR (FRANCE)	90 MnV 8; 90 MV 8	Z 85 WDCV 06-05-04-02; 6-5-2; HS6-5-2							Z 80 WKC 19-05-04-01; HS 18-1-1-5	Z 120 WDCV 06-05-04-03; HS6-5-3; Z 120 WDCV 06-05-04-04; HS6-5-4		
	AISI/ASM/ ASTM/SAE/ UNS/AA (US)	O2; T31502	M2; T11302	D7; T30407	A3; T30103	A7; T30107	W5; T72305	P4; T51604	T4; T12004	M3 Class 2; T11323		A532 IB; Ni-Hard 2; Ni-Cr-Lc; F45001	
	BS (UK)	BO 2; BO2	BM 2; BM2						BT 4			Grade 2 A	
	DIN (GERMANY)	90MnCrV8; 90 MnCrV 8	HS6-5-2; HS 6-5-2; S 6-5-2					6CrMo15-5; X 6 CrMo 4	HS18-1-2-5; S 18-1-2-5	HS6-5-3; HS 6-5-3; S 6-5-3	HS6-5-3C	G-X 260 NiCr 4 2; EN-GJN-HV520; EN-GJN-HB480; EN-JN2029	
	Werkstoff (GERMANY)	1.284	1.3343					1.234	1.3255	1.334	1.335	0.9620; 5.5602	
	EN (EUROPE)	90MnCrV8	HS6-5-2						HS18-1-2-5	HS6-5-3	HS6-5-3C	EN-GJN-HB480; EN-JN2029	
	GOST (RUSSIA)		R6M5										
	JIS (JAPAN)		SKH 51						SKH 3	SKH 52; SKH 53			
	SS (SWEDEN)		2722							2725		0512-00	
	UNE (SPAIN)	90 MnCrV 8; F.5229	F.550.A; F.5604						F.5530; HS 18-1-1-5	F.5605; 6-5-3			
	UNI (ITALY)	90 MoVCr 8 KU							HS 18-1-1-5				
	IS (INDIA)		T83MoW6Cr4V2										
	KS (REP. OF KOREA)		SKH 51										
	GB/YB/JB/ SY/NB (PRC)	9Mn2V	W6Mo5Cr4V2										

Material Designation in Accordance with Selected Standards

Standards		Material Group No.												
		40	40	40	40	40	40	40	40	40	40			
	NF/AFNOR (FRANCE)													
	AISI/ASM/ ASTM/SAE/ UNS/AA (US)				SAE J2477 AD 1400			F37006; A897 230-185-01; A897 (230/185/01); A897M 1600-1300-01; A897M (1600/1300/01); A897 Grade 5; SAE J2477 AD 1600						
	BS (UK)	Grade 1 A; Grade 1 B; Grade 1 C												
	DIN (GERMANY)	EN-GJN-HV350; EN-GJN-HB340; EN-JN2019	EN-GJN-HB400; EN-JN2059	EN-GJN-HB500	EN-GJS-HB400	EN-GJS-HB450	G-X 250 CrMoV 25							
	Werkstoff (GERMANY)	0.9610; 5.5600	5.5601	5.560	5.3406	5.3407	1.4192							
	EN (EUROPE)	EN-GJN-HB340; EN-JN2019	EN-GJN-HB400; EN-JN2059	EN-GJN-HB500	EN-GJS-HB400	EN-GJS-HB450								
	GOST (RUSSIA)							ChS15M4	ChS17	ChS17M3	ChKh16	ChKh22		
	JIS (JAPAN)													
	SS (SWEDEN)													
	UNE (SPAIN)													
	UNI (ITALY)													
	IS (INDIA)													
	KS (REP. OF KOREA)													
	GB/YB/JB/ SY/NB (PRC)													

Material Designation in Accordance with Selected Standards

Standards		Material Group No.							
		40	40	40	40	41	41	41	41
	NF/AFNOR (FRANCE)								
	AISI/ASM/ ASTM/SAE/ UNS/AA (US)					A532 IID 20% CrMo-LC; A532 Class II Type D; F45007	A532 IIC 15% CrMo-HC; A532 Class II Type C; 15% CrMo; F45005	A532 IIIA 25% Cr; A532 Class III Type A	A532 ID; Ni-Hard 4; Ni-HiCr; F45003
	BS (UK)					Grade 3 C	Grade 3 A; Grade 3 B	Grade 3 D	Grade 2 C; Grade 2 D; Grade 2 E
	DIN (GERMANY)					G-X 260 CrMoNi 20 2 1; EN-GJN-HV600(XCr23); EN-GJN-HB555(XCr18); EN-JN3039	G-X 300 CrMo 15 3; G-X 300 CrMoNi 15 2 1; EN-GJN-HV600(XCr14)	G-X 260 Cr 27; EN-GJN-HB555(XCr23); EN-JN3049	G-X 300 CrNiSi 9 5 2; EN-GJN-HV600;
	Werkstoff (GERMANY)					0.9645; 5.5609	0.9635; 0.9640; 5.5608	0.9650; 5.5610	0.9630; 5.5605
	EN (EUROPE)					EN-GJN-HB555(XCr18); EN-JN3039	EN-GJN-HB555(XCr14)	EN-GJN-HB555(XCr23); EN-JN3049	EN-GJN-HB555; EN-JN2049
	GOST (RUSSIA)	ChKh28D2	ChG7Kh4	ChYu30	ChN3KhMDSHa			ChWG	
	JIS (JAPAN)								
	SS (SWEDEN)							0466-00	0457-00
	UNE (SPAIN)								
	UNI (ITALY)								
	IS (INDIA)								
	KS (REP. OF KOREA)								
	GB/YB/JB/ SY/NB (PRC)								

Material Designation in Accordance with Selected Standards

Standards		Material Group No.								
		41	41	41	41	41	41	41	41	41
	NF/AFNOR (FRANCE)									
	AISI/ASM/ ASTM/SAE/ UNS/AA (US)	A532 IA; Ni-Hard; F45000; Ni-Cr-Hc	A532 IIIA 25% Cr							
	BS (UK)	Grade 2 B	Grade 3 E							
	DIN (GERMANY)	G-X 330 NiCr 4 2; EN-GJN-HV550; EN-GJN-HB510; EN-JN2039	G-X 300 CrMo 27 1; EN-GJN-HB555(XCr23)	G-X 250 CrMoV 25						
	Werkstoff (GERMANY)	0.9625; 5.5604	0.9655; 5.5610	1.419						
	EN (EUROPE)	EN-GJN-HB510; EN-JN2039	EN-GJN-HB555(XCr23)							
	GOST (RUSSIA)		20Ch25N20S2		ChKh9N5	ChKh16M2	ChKh22	ChKh28D2	ChYu30	ChN3KhMDSHa
	JIS (JAPAN)									
	SS (SWEDEN)	0513-00								
	UNE (SPAIN)									
	UNI (ITALY)									
	IS (INDIA)									
	KS (REP. OF KOREA)									
	GB/YB/JB/ SY/NB (PRC)									

ALPHABETICAL INDEX

	60° PARTIAL PROFILE THREADING FLT	730
	60° PARTIAL PROFILE THREADING FLT-CB	729
	60° PARTIAL PROFILE THREADING FLTF	728
	60° PARTIAL PROFILE THREADING FLTK	729
	60° PARTIAL PROFILE THREADING FLTP	730
A	ABC MAHDR-#-XL-JHP	884
	ACME THREADING FLA	773
	ACME THREADING FLA-PT-E	773
	ACME THREADING FLA-PT-I	774
	ACME THREADING FLAS	774
	AD-CCLNX	114
	AD-CRSNX	114
	ADMP D22	585
	ADMP D45	586
	AD-SET	113
	A/E-SCLXR/L-06X	130
	A/E-SDXNR/L-07	140
	A/E-SDZNR/L-07	141
	A/E-SEXPR/L-03	147
	A/E/S-SCLCR/L	146
	A/E/S-SDUCR/L	148
	A/E/S-STFPR/L	154
	A/E-STFPR-X	154
	A/E-SWLNR/L-04	135
	A/E-SWUCR	156
	AMERICAN STANDARD BUTTRESS THREADING FLT-B-A	785
	AMERICAN STANDARD BUTTRESS THREADING FLT-B-B	785
	Anti-Vibration Blades	312
	A-PCLXR/L	129
	API BUTTRESS THREADING FLDC-B-E	790
	API BUTTRESS THREADING FLDC-B-I	791
	API PARTIAL PROFILE THREADING FLD	789
	API ROUND THREADING FLDC-RD-75	787
	API ROUND THREADING FLDC-RD-75-CB	787
	API ROUND THREADING FLDC-RD-75M	787
	API THREADING FLDC-E	789
	API THREADING FLDC-I	789
	A-PSKNR/L-09	152
	A-PTFNR/L-X/G	142

A-PWLNRL/L-X/G	138
A-SDUCR/L-13-SL	147
A/S-MWLNRL/L-W	136
A/S-PCLNR/L	133
A/S-PCLNR/L-X/G	134
A/S-PDUNR/L	140
A/S-PWLNRL/L	137
A/S-STLPR/L	155
A/S-SVLBCR/L	150
A/S-SVLBCR/L	513
A/S-SVLFCR/L; A-SVUCR/L	149, 513
A/S-SVQCR/L	149, 512
A-SVLFNRL-AL-JHP	141
A-SVQNR/L-AL-JHP	142, 516
A-SVUNR/L	141
A-SXFOR-DR	157
A-SXFOR/L	157
AV-BUSH	844
AVC-D80-VH	129
AVC-DDMNR/L	126
AVC-DDUNR/L	126
AVC-DDUNR/L-VH	128
AVC-D-SIR/L	805
AVC-DVUNR/L	127
AVC-GAIC	390
AVC-GAIR/L	390, 806
AVC-GEAIR/L	389, 806
AVC-PCLNR/L	124
AVC-PCLXR/L	124
AVC-PTLNR/L	125
AVC-PXJNR/L	125
AVC-SCLCR/L	121
AVC-SCLXR/L-06X	121
AVC-SDJCN-Y	101
AVC-SDUCR/L	122
AVC-SDUCR/L-VH	128
AVC-SET	119
AVC-SET-LEV	120
AVC-SRDCN-Y	103
AVC-SVLCR/L	123
AVC-SVLCR/L-VH	128
AVC-SVMCR/L	124
AVC-SVPCR/L	123
AVC-SVQCR/L	123
AVC-SVUCR/L	122
AV-D	117

	AV-D-VH	127
	AV FLEX-SLEEVE	844
B	BGM N-J	553
	BGM R/L-J	553
	BGTR/L-B-JHP	553
	BHDN	499
	BI## V##-JHP	879
	BLKT AV-JHP	117, 844
	BMT## V85-JHP	877
C	C#-ABB	833
	C#-ADE	831
	C#-ADES	832
	C#-ADI	832
	CAMFIX ISO 26623-1	694
	CAMFIX - ISO 26623-1 Standard Quick Change Shanks	695
	C#-ASHA	830
	C#-ASHA-HPMC	834
	C#-ASHR/L	830
	C#-ASHR/L-45-HPMC	834
	C#-ASHR/L-HPMC	834
	C#-AV-C	118
	C#-AV-C-VH	119
	C#-AV-JHP	833
	CC95MT-SM	265
	CCET-WF	238
	CCGT-AF	270
	CCGT-AS	270
	CCGT-F1M-12P	232
	CCGT-F1M-20P	233
	CCGT-F1P	232
	CCMT-14	237
	CCMT/CCGT	237
	CCMT/CCGT-SM	236
	CCMT-CERMET	235
	CCMT-F3M	234
	CCMT-F3P	233
	CCMT-F3PW	233
	CCMT-M3M	235
	CCMT-M3P	234
	CCMT-PF	236
	CCMT-WG	238
	C# CXXNR/L-AD-JHP	114
	C#-DDJNR/L	40
	C#-DT##/2-L23	860
	C#-DTGNR/L	50
	CGFG 51-P8	661

C#-GHAD-8	699
C#-GHAD-JHP	699
C#-GHAIR/L	703
C#-GHAPR/L-8	700
C#-GHDR/L	301
C#-GHIC	702
CGHN-8-10D	315
CGHN 26-M	399
CGHN 32-DGM	400
CGHN 32-M	400
CGHN-D	310
CGHN-DG	310
CGHN-P8	311
CGHN-S	309
CGHR/L-12-14D	375
CGHR/L-P8DG	311
CGIN 26	391
CGPAD	308
CGPAD-JHP	309
C#-HAD	700
C#-HAPR/L	700
C#-HATA	701
C#-HELIR/L	289
C#-HFIR/L-MC	653
CKJNR/L	41
CKNNR/L	42
C#-MAHD	697
C#-MAHD-JHP	697
C#-MAHDR-45	696
C#-MAHPD	698
C#-MAHPD-JHP	698
C#-MULNR/L-MW	20
CNGG-F3N	266
CNGX-M3N	267
CNMA	188
CNMG-CERMET	183
CNMG/CNGG-PP	189
CNMG/CNGG-SF	187
CNMG/CNGG-TF	189
CNMG-F3M	185
CNMG-F3P	181
CNMG-F3S	186
CNMG-GN	190
CNMG-M3M	185
CNMG-M3P	182
CNMG-MR	191

CNMG-NF	187
CNMG-NR	190
CNMG-R3M	186
CNMG-R3P	182
CNMG-VL	186
CNMG-WF	187
CNMG-WG/NRW	188
CNMM-H3P	193
CNMM-H4P	193
CNMM-H5P	193
CNMM-M4PW	192
CNMM-NR	194
CNMM-R3P	192
CNMS-12	272
CNMX-M3/4MW	191
CNMX-M3/4PW	191
COMG-R3P-IQ	184
COMM-R3P-IQ	184
C#-PCLNR/L-12-JHP	26
C#-PCLNR/L-X	30
C#-PCLNR/L-X-JHP	31
C#-PCLOR/L-IQ	34
C#-PDJNR/L-JHP	38
CPGT-SM	239
CPMT-PF	239
C#-PWLNR/L-08-JHP	13
C#-PWLNR/L-X	17
C#-PWLNR/L-X-JHP	18
C#-PWLOR/L-IQ	23
C#-Q3-SMXCN-SL-Y	10
C#-Q3-SMXCR/L-SL	10
C#-Q6-DMXNN-SL-Y	8
CR HFIR-M	655
CROWN (ECD)	582
CR THDN-IQ	371
C#-SCLCR/L-JHP	71
C#-SDJCN-13-Y	100
C#-SDJCR-JHP	78
C#-SDJCR/L	77
C#-SDJCR/L-13-SL-JHP	75
C#-SDNCN	84
C#-SDNCN-13-SL-JHP	83
CSDPN	97
C#-SER/L	799
C#-SH-E-JHP	704
C#-SH-JHP	704

C#-SIR/L	803
C#-SLANR/L-TANG	60
C#-SRDCN-16-Y	103
C#-SRGCR-12-JHP	94
C#-SRGCR/L	94
CSSPR/L	97
C#-SVJCR/L	87
C#-SVJCR/L-JHP	87
C#-SVJNR/L-F	42
C#-SVVCN	91
C#-TBK-R/L	695
C#-TBU	696
CTFPR/L	98
CTGPR/L	97
C#-V60-JHP	878
CXGG-M3N-P	230
CXMG-F3M	230
CXMG-F3P	229
CXMG-M3M	230
CXMG-M3P	229
CXMU-F3M	231
CXMU-F3P	231
D D6NMG-F3P	209
D6NMG-M3M	209
D6NMG-M3P	209
DCBNR/L	33
DCET-WF	247
DCGT-AF	271
DCGT-AS	270
DCGT-F1M-12P	243
DCGT-F1M-20P	244
DCLNR/L	32
DCLNR/L-JHP-MC	32
DCMT-14	247
DCMT-CERMET	243
DCMT/DCGT	246
DCMT/DCGT-PF	245
DCMT/DCGT-SM	246
DCMT-F3P	240
DCMT-F3P-SL	240
DCMT-M3M	241
DCMT-M3M-SL	242
DCMT-M3P	241
DCMT-PF-SL	244
DCMT-SM-SL	245
DDJNR/L	39

DDJNR/L-JHP-MC	39
DGAD-B-D	538
DGAD/HGAD	537
DGAQ	580
DGAQ-JHP	580
DGFH	293, 525
DGFH-JHP	294, 526
DGFHL-26B-TR-D	528
DGFHR/L	526
DGFHR/L-BC-JHP	527
DGFHR/L-B-D..(R/L)	528
DGFS	527
DGHAL-DECO	536
DGN-B	542
DGN-C-XL	551
DGN/DGNC/DGNM-C	539
DGN/DGNM-J/JS/JT	544
DGN-J/JS-D	543
DGN-J-XL	552
DGN-LF/LFT	546
DGN-MF	541
DGN-P	548
DGN-T	541
DGN-UT/UA	547
DGN-W	540
DGN-WP	549
DGN-Z	546
DGPAD-D12/22-JHP	539
DGPAD-JHP	538
DGPAD-XL-JHP	538
DGR/L-B	542
DGR/L-C DGRC/LC-C	540
DGR/L-C-XL	551
DGR/L-J/JS	545
DGR/L-J/JS-D	543
DGR/L-J-XL	552
DGR-P	548
DGR-WP	549
DGR-Z/ZS	547
DGTR/L	534
DGTR/L-B/BC-D	533
DGTR/L-BC-T	535
DGTR/L-B-D-JHP-SL	531
DGTR/L-B-D-JHP-SL-MC	532
DGTR/L-B-D-SH	529
DGTR/L-B-D-SH (NARROW CUT)	530

DGTR/L-B-D-TR	535
DGTR/L-B-T-SH	534
DGTR/L-XL	536
D/HGAD RE/LE-JHP	561
DIN69880-HYDRO	843
DNGG-M3N	267
DNGP-F2M	197
DNGP-F2P	195
DNMA	203
DNMG-CERMET	199
DNMG/DNGG-PP	201
DNMG/DNGG-SF	199
DNMG/DNGG-TF	202
DNMG-F3M	197
DNMG-F3P	196
DNMG-F3S	198
DNMG-GN	202
DNMG-M3M	198
DNMG-M3P	196
DNMG-NF	200
DNMG-NR	202
DNMG-PF	200
DNMG-VL	201
DNMG-WG	200
DNMM-NM	203
DNMM-R3P	203
DNMS-12	272
DNMX-M3P	204
DSBNR/L	52
DSDNN	50
DSKNR/L	51
DSSNR/L	51
DT##/2 MAHD#-#-XL-JHP	860
DT30/2 ADR-##-20-55	860
DT30/2 ASH# 16/20-1-35080	861
DT30/2 ##L70WN	860
DTF50 FSHDR-8	508
DTF50 FSHIUR	509
DTF50 SVXCR-16X2	510
DTF50 SVXCR-22	509
DTGNR/L	50
DWLNR/L	13
DWLNR/L-JHP-MC	14
DXJNR/L-X-JHP-MC	35
E E-GEHIR / E-GHIR	383
EIR/L U	722

EPGT-F1P	238
E-PWLNLR/L-HEAD	138
ER-BUT	790
ER-EL	791
ER-ISO 3M-Q	733
ER/L-55°	715
ER/L-60°	721
ER/L-60°	722
ER/L-ABUT	784
ER/L-ACME	771
ER/L-API	788
ER/L-API RD	786
ER/L-BSPT	766
ER/L-ISO	734-736
ER/L-NPT	761
ER/L-RND	792
ER/L-SAGE	783
ER/L-STACME	768
ER/L-TR	780
ER/L-UN	745-748
ER/L-UNJ	775
ER/L-W	755, 756
ER-MJ	779
ER-NPT 3M-Q	760
ER-NPTF	765
ER-PG	782
ER-W 3M-Q	755
E-SCLCR/L-HEAD	145
E-SDUCR/L-HEAD	148
E/S-SWUBR/L	155
E-STFCR-HEAD	151
E-STFPR-HEAD	153
EX C# (CAMFIX extension)	701
F FGHDUR	508
FGPAM	508
FLASR/L	807
FLSR/L	807
FSHDR	507
FSHIUR	506
FSPA/FSMA	507
FTB	402
FTHN	402
G GADR/L-8	314
GADR/L-JHP	315
GAFG-R/L-8	661
GAIR/L	389

GDK	336
GDMA	332, 506
GDMF	317
GDMM-CC	664
GDMN	319
GDMT	317
GDMU	319
GDMW 2.4	339, 590
GDMY	318, 663
GDMY-F	321, 663
GDMY (full radius)	320, 663
GDP	336
GDPY	323
GEAIR/L	383
GEHIMR/L	380
GEHIMR/L-SC	380
GEHIR/L	381
GEHIR/L-SC	382
GEHIUR/L	382
GEHSR	427
GEHSR/L-SL	426
GEMI	384
GEMI (full radius)	384
GEPI	385
GEPI (full radius)	386
GEPI-MT	727
GEPI-RX/LX	386
GEPI-UN/UR/UL	386
GEPI (W<M)	385
GEPI-WT	718
GFF-N	673
GFF-R/L	673
GFHR/L-JHP	660
GFI ST-ER	848
GFQR	633
GFT-C	586
GFT-J	585
GHAIR/L-GE	382
GHAIR/L-GI	388
GHAIR/L-SC-GE	383
GHAPR/L-8	314, 660
GHAR/L-8	314, 660
GHAR/L-JHP	315
GHDKR/L	503
GHDR/L-8A	503
GHDR/L-JHP (long pocket)	313

GHDR/L-JHP-MC (short pocket)	304
GHDR/L-JHP (short pocket)	303
GHDR/L (long pocket)	313
GHDR/L/N 12/14	375
GHDR/L (short pocket)	302
GHFG-R/L-8	659
GHFGR/L-8	659
GHGR/L	305
GHIC-50	389
GHIC-70	398
GHIC-85	398
GHIFR/L-A	503
GHIR/L-C (W=4-6.4)	387
GHIR/L-SC (W=2-4.8)	388
GHIR/L (W=1.9-6.4)	387
GHIR/L (W=7.0-8.3)	398
GHIUR/L	388
GHIUR/L-C-22.5A-8V	502
GHIUR/L-C-A (15° & 27.5°) Bars	502
GHIUR/L-UC	502
GHMPR/L	300
GHMR/L	300
GHMUR/L	335
GHSR/L	428
GHSR/L-JHP-SL	429
GHVR/L	503
GIA-K (long pocket)	330, 662
GIA-K (W=3-6)	329
GIF	328
GIF-E (W=4-6)	322
GIF-E (W=4-6 full radius)	324
GIF-E (W=8,10)	322, 662
GIF-E (W=8,10 full radius)	324
GIF (full radius)	329
GIFG-E (W=8)	661
GIFI	395
GIFI-E	392
GIFI-E (full radius)	392
GIF (long pocket)	328
GIG	326
GIM-C	587
GIMF	317
GIMIY	391
GIM-J	587
GIM-J-RA/LA	588

GIMM 8CC	664
GIMN	319
GIMT	316
GIM-UT	589
GIM-UT-RA/LA	590
GIM-W	588
GIM-W-RA/LA	589
GIMY	318
GIMY 1260	320
GIMY-F	321
GIMY (full radius)	320
GIMY-UN	335
GINI-E	393
GIP	327
GIPA 8-35V (V-shape)	505
GIPA (full radius W=3-6)	333, 504
GIPA/GIDA 8 (full radius)	334, 505
GIPA (W=3-6)	332
GIP-E	323
GIP-E (full radius)	325
GIP (flat top CW<BW)	325
GIP (full radius)	327
GIP (full radius CW<BW)	326
GIPI	394
GIPI (CW<BW)	393
GIPI-E	392
GIPI (full radius)	395
GIPI (full radius CW<BW)	394
GIPI-RX/LX	395
GIPI-UR/UL	396
GIPM-A46 / GIP-1250	430
GIP-RX/LX	334
GIP-UN	335
GIPY	331
GIQR/L 8	471
GIQR/L 8-R	471
GIQR/L 11	472
GIQR/L 11-15	473
GIQR/L 11-15-R	473
GIQR/L 11-R	472
GIQR/L-A18	473
GIQR/L-B18	474
GIQR/L-MT	474, 731
GIQR/L-WT	474, 719
GITM	330
GITM (full radius)	331

H

GIVR/L	316
GPV	336
GQHINR/L	379
GQIN	379
GRIP	294, 657
GRIPA	296
GRIPA (full radius)	296
GRIP (full radius)	295, 658
GRIP-T	295
GTGA	365
GTMA	366
HAI-C	651
HAPR/L	645
HAR/L	645
HELIIR/L	397
HELIR/L	290
HFAER/L-4	646
HFAER/L-5T, 6T	647
HFAIR/L-4	651
HFAIR/L-DG	652
HFFA	637
HFFH	637
HFFR/L-T	645
HFHPR/L-M	648
HFHR/L-3T	638
HFHR/L-4T	639
HFHR/L-5T	640
HFHR/L-6T	641
HFHR/L-M	647
HFIR/L-MC	654
HFPAD-3	643
HFPAD-4	643
HFPAD-5	644
HFPAD-6	644
HFPAD-JHP	642
HFPN	655
HFPR/L	656
HFPR/L (full radius)	656
HGAER/L-3	646
HGAIR/L-3	648
HGFH	292
HGHR/L-3	638
HGN-C	549
HGN-J	550
HGN-UT	551
HGPAD	291

HGPAD-JHP	291
HGPL	658
HGR/L-C	550
HGR/L-J/JS	550
HLPGR/L	337
HMSN-New Britain	537
HSK 63 HATA	706
HSK A63TM ABB	839
HSK A63TM-ASHN-45-HPMC	839
HSK A63TM-ASHR/L-45-HPMC	839
HSK A63WH-ASHR/L-2	837
HSK A63WH-ASHR/L-3	837
HSK A63WH-ASHR/L-45	836
HSK A63WH-ASHR/L-45-HPMC	838
HSK A63WH-ASHR/L-HPMC	838
HSK A63WH-DDJNR/L	40
HSK A63WH-DDNNN	41
HSK A63WH-MAHDOR	705
HSK A63WH-MAHDR-45	705
HSK A63WH-MAHUR/L	706
HSK A63WH-MULNR-J12MWX2	21
HSK A63WH-MULNR/L-MW	20
HSK A63WH-MUMNN-MW	21
HSK A63WH-SDJCN-13-Y	99
HSK A63WH-SRDCN-Y	102
HSK A63WH-SVJCR/L	87
HSK A63WH-SVNNN-F	44
HSK A-TM-ASHR/L-1-HPMC	838
HSK A-WH ABB	837
HSK A-WH-ASHN-45	836
HSK A-WH-ASHR/L-1	836
HSK A-WH-TBK-R/L	706
HSK-C#	835
HSK T ## V60-JHP	878
I IH-HFAIR	649
IH-HFPAD	650
IHSR-MIFR	634
IH-TNFPAD	669
IM-GHAD-8	708
IM-HAD	708
IM-HAPR/L	708
IM-HFIR-MC	653
IM-MAHD	707
IM-MAHPD	707
IM-TBU	707
IR-BUT	790

IR-EL	791
IR/L-55°	716
IR/L-60°	723
IR/L-60°	724
IR/L-ABUT	784
IR/L-ACME	772
IR/L-API	788
IR/L-API RD	786
IR/L-BSPT	767
IR/L-ISO	737-741
IR/L-NPT	762
IR/L-NPTF	765
IR/L-PG	782
IR/L-RND	792
IR/L-SAGE	783
IR/L-STACME	769
IR/L-TR	781
IR/L-UN	749-752
IR/L-UNJ	776
IR/L-W	757, 758
IR-MJ	778
J JHP CONNECTOR	112, 496
JHP COPPER SEAL	112, 496
JHP ELBOW	111, 495
JHP HOSE	111, 495
JHP NIPPLE	111, 495
JHP QC CONNECTOR	494
JHP QC ELBOW	494
JHP QC HOSE	494
JHP QC KIT	493
K KIT PICCO Face	632
KIT PICCO SET	463
KNMX	204
KNUX	204
L LNMX 19/30	227
LNMX-HF	227
LNMX-HM	226
LNMX-HT	226
LNMX-WG	227
LOMX-H6P	225
LPGIR/L	337
M MAHPR/L	307
MAHPR/L-JHP	308
MAHPR/L-XL-JHP	642
MAHR/L	306
MAHR/L-JHP	306

MAHR/L-JHP-MC	307
MAHR/L-MG-XL-JHP	563
MAHR/L-MG-XL-JHP-MC	563
MA##### V##-JHP	878
MCLNR/L	26
MEFL	635
MFHR-JHP	633
MG	470
MGCH	470
MGCH-C (face)	632
MGSIR/L	156, 805
MG STFPR-X	154
MG-SWUBR/L	156
MG-SWUCR	157
MGUHR	467
MIFHR	468, 633
MIFR	634
MIGR 8	469
MINCUT KIT	635
MITR 8-MT	731
MIUR 8	469
MI## V60-JHP	879
MORI## V85-JHP	878
MS-ES#####-GWS-MG-JHP	861
MS##-##-MG-JHP	859
MTENN-W	49
MTJNR/L-W	49
MULNR/L-12MW	19
MVJNR/L	43
MVVNN	45
MWLNR/L-13W	22
MWLNR/L-W	22
N NMAHR/L-JHP	560
NPT THREADING FLDC-NPT-E	764
NPT THREADING FLDC-NPT-I	764
NPT THREADING FLDC-V-75	764
NQCH-DGTR/L-D22-SH-JHP	530
NQCH FIXTURE	425
NQCH-GHSR/L-JHP	428
NQCH-JHP	80, 424
NQCH-PCHR/L-24-JHP	348
NQCH-PCHR/L-S-JHP	433
NQCH-PCLXR/L-S-JHP	67
NQCH-PTJNR/L-S-JHP	48
NQCH-SCACR/L-S-JHP	72
NQCH-SCHR/L-BF-JHP	408

NQCH-SCLXR/L-JHP	69
NQCH-SDACR/L-S-JHP	79
NQCH-SDJCR/L-S-JHP	76
NQCH-SDJNR/L-S-JHP	36
NQCH-SDNCN-S-JHP	84
NQCH-SER/L-JHP	800
NQCH-SVACR/L-S-JHP	89
NQCH-SVJCR/L-S-JHP	85
NQCH-SVVCN-S-JHP	91, 512
NQCH-SWLNLR/L-S-JHP	11
NQCH-TGVR/L-JHP	405
NQCH-Y-SCHR-BF-JHP	408
NQCH-Y-SDJCR-S-JHP	77
NQCH-Y-SVJCR-S-JHP	86
NT## V60-JHP	879
O OKUMA # V60-JHP	879
P PADR/L	338
PCAD RE/LE-JHP	561
PCADR/L	353
PCADR/L 34N-RE	354
PCADR/L-JHP	353
PCADRS/LS-JHP	354
PCBNR/L	27
PCBOR/L-IQ	34
PCHBR/L	355
PCHPR/L	352, 674
PCHPRS/LS	675
PCHR/L-24	346
PCHR/L-24-JHP	347
PCHR/L-24-JHP-MC	348
PCHR/L-24-JHP-QC/MC	349
PCHR/L-27-JHP-MC	350, 377
PCHR/L-34	351
PCHR/L-34-JHP	351
PCHR/L-34-JHP-MC	352
PCHR/L-D-IQ	591
PCHR/L-D-JHP	592
PCHRS-24 JHP-QC/MC	349
PCHRS/LS	350
PCHRS/LS-17	339, 431
PCHRS/LS-17-JHP	340, 432
PCLCR/L-S	72
PCLCR/L-S-JHP	73
PCLCR/L-S-JHP-MC	73
PCLNR/L	24
PCLNR/L-12-JHP	25

PCLNR/L-PAD-JHP	25
PCLNR/L-X	27
PCLNR/L-X-JHP	28
PCLNR/L-X-JHP-MC	29
PCLOR/L-IQ	33
PCLXR/L	65
PCLXR/L-JHP	65
PCLXR/L-JHP-MC	67
PCLXR/L-S	66
PCLXR/L-S-JHP	66
PDACR/L-S	74
PDACR/L-S-JHP	82
PDACR/L-S-JHP-MC	82
PDJNR/L	36
PDJNR/L-JHP	37
PDJNR/L-JHP-MC	37
PDJNR/L-PAD-JHP	38
PDJNR/L-S	35
PENTA 17-ER/EL	344, 435
PENTA 17-MT-RS/LS	438, 725
PENTA 17-NP-RS/LS	344, 434
PENTA 17-NX-RS	345, 434
PENTA 17-P-RS/LS	341, 435
PENTA 17-P-RS/LS (full radius)	343, 436
PENTA 17R/L-P-RS	342, 437
PENTA 17R/L-SP-RS	342, 437
PENTA 17-WT-RS/LS	438, 717
PENTA 24-BSPT	767
PENTA 24-ISO	742
PENTA 24-MT	725
PENTA 24N-C	359, 601
PENTA 24N-C (full radius)	360
PENTA 24N-C-SL	356, 595
PENTA 24N-J	358, 597
PENTA 24N-J (full radius)	359
PENTA 24N-J-RS	362
PENTA 24N-J-SL	356
PENTA 24N-NF-RS-SL	363
PENTA 24N-NF-RSSL (full radius)	363
PENTA 24N-PF (full radius)	361
PENTA 24N-PF/P	360, 602
PENTA 24N-PF-RS	362
PENTA 24-NPT	763
PENTA 24N-RS/LS	362
PENTA 24N-Z	361, 599
PENTA 24R-C	601

PENTA 24R/L-DSL	357, 596
PENTA 24R/L-J	598
PENTA 24R/L-Z	600
PENTA 24R-P	602
PENTA 24-UN	753
PENTA 24-W	759
PENTA 24-WT	717
PENTA 34F-R/L	674
PENTA 34F-RS/LS	675
PENTA 34N-C	364, 603
PENTA 34N-J	365, 604
PENTA 34N-PB	364, 605
PENTA 34R/L-C	603
PENTA 34R/L-J	604
PENTA 34R/L-PB	605
PENTA D-N-C	593
PENTA D-N-J	593
PENTA D-N-PB	594
PENTA D-R/L-C	594
PENTA D-R/L-J	593
PENTA D-R/L-PB	595
PENTAS 27 blanks	363, 377
PHAR/L	338
PHGR/L	338
PHSR/L	427
PICCO-010/610(Face Grooving)	627
PICCO-010(Round Face Groove)	628
PICCO-015 (Face Grooving)	632
PICCO-016/020(Face Grooving)	631
PICCO-55°-Thread	462, 720
PICCO-620(Groove Along Shaft)	629
PICCO ACE	440, 808
PICCO ACE-BH	441
PICCO ISO Full Profile	463, 743
PICCO ISO Full Profile Fine	463, 744
PICCO-MFT	733
PICCO/MG PCO (Holder)	441, 808
PICCO R 050.20	449
PICCO R/L 002-007	453
PICCO R/L 004-007 (Radius)	454
PICCO R/L 047	458
PICCO R/L 050, 053, 055	446, 447
PICCO R/L 050-C	448
PICCO R/L 060	456
PICCO R/L-60°-Thread	461, 732
PICCO R/L 070	457

PICCO R/L 080	460
PICCO R/L 090	451
PICCO R/L 520	455
PICCO R/LHD 050	450
PICCO R/LM	459
PICCO R/LX050	459
PICIN-A-SCLCR/L	464
PICIN-A-SIR/L	466, 744
PICIN-A-SWUBR/L	465
PICIN-MGSIR/L	466, 744
PICIN-SCLCR/L	464
PICIN-SWUBR/L	465
PICJ RF-D8-T(Face Grooving)	631
PICJ RF-D16/20-T(Face Grooving)	630
PICJ RF-T-20(Grooving Along Shaft)	629
PICJ RF-T(Round Face Grooving)	628
PICJ R/LBC	457
PICJ R/LBT	460
PICJ R/LCH	455
PICJ R/LF-D6/8-T(Face Grooving)	626
PICJ R/LG	452
PICJ R/LP	454
PICJ R/LT20	445
PICJ R/LT20-C	447
PICJ R/LT20-H	450
PICJ R/LT45	456
PICJ R/LT47	458
PICJ R/LT90	451
PICJ R/LT2020	449
PICJ R/LTH (60° Threading)	461, 732
PICJ RTH (55° Threading)	462, 720
PLANR/L-TANG	58
PLBOR/L	57
PMC R/L	443
PQFNR/L	64
PQLCR/L	95
PQLCR/L-S	95
PQLNR/L	63
PQSNR/L	64
PRDCN	95
PRGCR	95
PRWR/L	62
PRWR/L 175-CA	63
PRWR/L 177-CA	63
PSANR/L	64
PSBNR/L	56

PSBNR/L-JHP-MC	57
PSBOR/L-IQ	56
PSDNN	53
PSDNN-JHP	53
PSDON-IQ	52
PSKNR/L	54
PSSNR/L	54
PSSNR/L-JHP	55
PSSNR/L-JHP-MC	55
PTFNR/L	48
PTGNR/L	45
PTGNR/L-X	46
PTGNR/L-X-JHP	47
PTGNR/L-X-JHP-MC	47
PVACR/L-S	84
PVACR/L-S-JHP	89
PVACR/L-S-JHP-MC	90
PWLNLR/L	12
PWLNLR/L-08-JHP	12
PWLNLR/L-S	11
PWLNLR/L-X	14
PWLNLR/L-X-JHP	15
PWLNLR/L-X-JHP-MC	16
PWLOR/L-IQ	23
PWXOR/L-TF-IQ	24
Q Q3-MCMT-R3M-SL	171
Q3-MCMT-R3P-SL	172
Q3-SMXCN-SL-JHP	9
Q3-SMXCR/L-SL-JHP	9
Q6-DMXNN-SL-JHP	8
Q6-DMXNR/L-SL-JHP	8
Q6-MNMG-M3M-SL	171
Q6-MNMG-M3P-SL	171
QCMT-PF	259
QCMT-SM	259
QGI 30N-P	368
QGI 30N-PF	367
QNMG-GN	229
QNMG-NF	228
QNMG-PP	228
QNMG-TF	228
QTHR/L-30-JHP-MC	366
RCMT-14	257
RCMT-M3P	257
RCMT-SR	257
RCMX	258

S

RCMX-M3P-R	258
RCMX-NR	259
RCMX-R3P-R	258
RE-C#	702
RNMG	216
S/A-SQLCR/L	144
S/A-SVJCR/L	150
SBB	158
SBTB-JHP-T/R	422
SBTH-ER	420
SBTH-JHP	421
SBTH-PICCO	420, 442
SBTS##S-JHP	423
SBTT#-16ER/L-JHP	418
SBTT/L/A-SDJNR/L07-JHP	419
SBTT#-MIFHR-JHP	420
SBTT#-PCHRS/LS-17-JHP	419
SBTT-PCLXR/L09-JHP	418
SBTT#-SCHR/L22-JHP	419
SBTT#-SCLCR/L-JHP	418
SBTT#-SDJCR/L-JHP	415
SBTT-SDNCN-JHP	415
SBTT#-SVJBR/L-JHP	417
SBTT#-SVJCR/L-JHP	416
SBTT#-SVQCR/L-JHP	417
SBTT#-SVUCR/L-JHP	416
SBTT-SVVCN-JHP	416
SC45MT-SM	266
SCACR/L-S	72
SCB	500
SCB (light fit / tight fit)	500
SCGT-AS	268
SCHR/L-22BF	407
SCHR/L-22BF-JHP	407
SCHR/L-41BF	412
SCIR-22-MTR-ISO	742
SCIR/L-22-AD	409
SCIR/L-22-AR/AL	409
SCIR/L-22-BR/BL/BRA/BLA	409
SCIR/L-22-ER/EL/ERA/ELA	410
SCIR/L-22-MTR/MTL	726
SCIR/L-22-NP	412
SCIR/L-22-N/R/L	411
SCIR/L-22-NX	412
SCIR/L-41-AD	413
SCIR/L-41-AR/AL	413

SCIR/L-41-BRA/BLA	413
SCIR/L-41-ERA/ELA	413
SCIR/L-41-MTR/MTL	726
SCIR/L-41-NP	414
SCIR/L-41-N/R/L	414
SCLCR/L	70
SCLCR/L-PAD-JHP	71
SCLCR-PAD	71
SCLXR/L 06X	68
SCLXR/L 06X-JHP	68
SCLXR/L 06XS	68
SCLXR/L 06XS-JHP-MC	69
SCMT-14	254
SCMT-19	254
SCMT-F3M	253
SCMT-F3P	252
SCMT-M3M	253
SCMT-M3P	253
SCMT-SM	254
SC-PICCO	420, 442
S-CSKPR	152
S-CTFPR/L	153
SC-T (sleeves)	840
SDACR/L-S	79
SDACR/L-S-SL-JHP	81
S-DCLNR/L	131
S-DDUNR/L	139
SDHCR/L-S	79
SDJCR/L	75
SDJCR/L-13-SL	74
SDJCR/L-JHP-MC	76
SDJCR/L-PAD-JHP	78
SDJCR-PAD	78
SDJCR-SL-PAD-JHP	74
SDNCN	83
SDNCN-13-SL	83
S-DWLNLR/L	130
SER-D	800
SER/L	798
SER/L-JHP	799
SER/L-JHP-MC	800
SGAQ	431
SGBHR/L	556
SGFFA	671
SGFFH	672
SGFFR/L	670

SGTBF	691
SGTBK	691
SGTBR/L	691
SGTBU/SGTBN	690
SH-D	116
SH-S#-N-AVC	119
SIR/L	801
SKJNR/L	41
SLANR/L-15-TANG-JHP	60
SLANR/L-TANG	59
SLBNR/L-TANG	61
SLFNR/L-TANG	61
S-MTLCR/L-W	151
S-MTLNR/L-W	143
S-MULNR-MW	139
SNMA	222
SNMG-EM-M/R	221
SNMG-F3M	218
SNMG-F3P	216
SNMG-F3S	219
SNMG-GN	221
SNMG-M3M	218
SNMG-M3P	216
SNMG-NR	222
SNMG-PP	220
SNMG-R3M	219
SNMG-R3P	217
SNMG-TF	220
SNMG-VL	219
SNMM-H3P	223
SNMM-H4P	224
SNMM-H5P	224
SNMM-NM	224
SNMM-NR	225
SNMM-R3P	223
SNMM-R4P	223
SNMX 150608R-..	273
SNMX 150708R-..	273
SOMG-R3P-IQ	217
S-PLANR-TANG	132
SPMR	260
S-PQFNR/L	132
S-PQLNR/L	133
S-PTFNR/L	143
SRDCN	94
SRGCR-12-JHP	93

SRGCR/L	93
SSBCR/L	92
S-SLANR/L-TANG	131
SSSCR/L	92
S-STFCR/L	151
S-STLCR/L	152
S-SUXCR/L-CM	144
ST-ER	845
ST-ER-MF-D (double-ended)	847
ST-ER-MF (mini flat)	846
STFCR/L	92
STGCR/L	93
STUB ACME THREADING FLAS-PT-E	770
STUB ACME THREADING FLAS-PT-I	770
SUXCR/L-CM	70
SVACR/L-S	88
SVANR/L-FS	42
SVHNR/L-AL-JHP	44, 515
SVJCR/L	85, 511
SVJCR/L-16-JHP	86, 511
SVJCR/L-PAD-JHP	88
SVJCR-PAD	88
SVJNR/L-F	42
SVPCR/L-S	92
SVVCN	90, 511
SVVNN-AL-JHP	44, 515
SVVNN-F	43
SVXCR/L	91
SVXCR/L	512
SWAPR/L-S	96
SWAPR-PAD	96
SWDPR/L	96
SXCIB	498
SXCIR	401
SXCNN	401
T TAGB/TAGBA	375
TAG N-A	573
TAG N-C (full radius)	569
TAG N-C/W/M	568
TAG N-HF	568
TAG N-J/JS/JT	570
TAG N-LF	572
TAG N-MF	570
TAG N-T	573
TAG N-UT	572
TAGPAD-JHP	562

TAGPAD-XL-JHP	562
TAGPAD-Y-JHP	584
TAG R/L-C	569
TAG R/L-J/JS	571
TCGT-AS	269
TCMT-F3P	255
TCMT-M3M	256
TCMT-M3P	255
TCMT-PF	256
TCMT-SM	256
TGAD	560
TGAD RE/LE-JHP	560
TGAQ	579
TGAQ-ECD (JET-CROWN)	582
TGAQ-JHP	578
TGBHR/L	372
TGBHR/L-JHP	373
TGDR/L	297
TGFH-JHP	555
TGFHL-TR	567
TGFH-MB	559
TGFH/R/L	374, 554
TGFHR/L	556
TGFHR/L-JHP	557
TGFH-S	555
TGFS	564
TGHN 26-M	397
TGHN-D	298
TGHN-S	298
TGIR/L-C	396
TGMA	299
TGMF (full radius)	299
TGMF/P	299
TGPAD	297
TGPAD-JHP	298
TGSU	558
TGTBQ-ECD-JHP (JET-CROWN)	581
TGTBQ-JHP	574
TGTBQ-JHP-ECD-MC	581
TGTBQ-JHP-MC	575
TGTBQ-JHP-RIB	576
TGTBU	558
TGTBU-JHP	559
TGTBY-JHP	583
TGTR/L-2T..SH-L120	566
TGTR/L-D	567

TGTR/L-IQ	564
TGTR/L-IQ-2Z	565
TGTR/L-JHP	565
TGTR/L-JHP-MC	566
TGV N	406
TGV R/L	406
TGVR/L-JHP	405
THBR/L/N-IQ	370
THDR/L-IQ	370
THDR/L/N	376
THMPR/L D22-JHP	585
THMPR/L D45-JHP	586
THQR/L	430
Thread anvils EL/IR	793
Thread anvils ER/IL	794
TIGER	376
TIGER-IQ	371
TIGERV	376
TIPI-MT	728
TIPI-WT	719
TIP-MT	727
TIP-P-BSPT	768
TIP-P-BSW	759
TIP-P-ISO	743
TIP-P-NPT	763
TIP-P-UN	753
TIP-WT	718
TNFFA-IQ	666
TNFFH-IQ	665
TNF GN-IQ	667
TNF-M-IQ	667
TNFPAD-XL-JHP	668
TNF-P-IQ	666
TNGG-M3N	267
TNMA	215
TNMG-F3M	211
TNMG-F3P	210
TNMG-F3S	212
TNMG-FFG-CERMET	212
TNMG-GN	215
TNMG-M3M	211
TNMG-M3P	210
TNMG-NF	214
TNMG-PF	213
TNMG-SF	213
TNMG-TF	213

TNMG/TNGG-PP	214
TNMG-VL	214
TNMM-NR	215
TNMS-12	271
TNMX-M3/4MW	212
TNMX-M3/4PW	210
TPGB	262
TPGB-XL	262
TPGH-R/L	263
TPGH-XL	263
TPGT-SP	261
TPGX	263
TPMR	260
TPMR-FTF	261
TPMR-PF	260
TPMT	261
TPMT-PF	262
TR45 MAHDR-#-XL-JHP	883
TR45TNL MAHDN-R-XL-JHP	883
TR TNK36 MAHDL-R-XL-JHP	884
TSU-M08 V60-JHP	879
U UBHCR/L	691
UMGR	467
UMGR-A55	468, 719
UMGR-A60	468, 731
UNJ THREADING FLJ	777
UNJ THREADING FLJF	777
UNJ THREADING FLJK	778
UNJ THREADING FLJP	777
UN THREADING FLTC-E	754
UN THREADING FLTC-I	754
V V-ASH-MC	882
VCET-WF	251
VCGT-AF	269, 514
VCGT-AS	269, 514
VCGT-DW (PCD)	515
VCGT-F1M-12P	250
VCGT-F1M-20P	250
VCGT-MD/PF	251
VCMT-14	252
VCMT-F3M	249
VCMT-F3P	248
VCMT-FPC-CERMET	250
VCMT-M3M	249
VCMT-M3P	248
VCMT-SM	251

VCMW	252
VDI AV-JHP	843
VDI-B1/B4A-JHPMC	840
VDI-B1/B4AK-JHPMC	841
VDI-B2/B3A-JHPMC	841
VDI-B2/B3AK-JHPMC	841
VDI-C1/C4A-JHPMC	841
VDI-C1/C4AK-JHPMC	842
VDI-C2/C3A-JHPMC	842
VDI-C2/C3AK-JHPMC	842
VDI-DTF50	510
VDI-DTF50E-L60R	510
VDI##-P V60-JHP	877
VDI#### V##-JHP	877
V## MAHD-XL-JHP	881
V## MAHD#-#-XL-##-JHP	880
VNGG-M3N	268
VNGU-R3N	268
VNGU-R3N	516
VNMG-F3M	205
VNMG-F3P	205
VNMG-F3S	206
VNMG-FNF-CERMET	206
VNMG-M3M	205
VNMG-SF	206
VNMG-TF	207
VNMG/VNGG-NF	207
VNMM-PP	207
VNMS-12	272
V## SQ#-#-D65-ECD	882
V## SQ#-#-D82-JHP	577
V## SQ#-#-D82-JHP	881
V## V##-L##	882
W WBGT	264
WBMT	264
WCGT	264
WNGG-F3N	266
WNGP-F2M	174
WNGP-F2P	172
WNMA/WNMA-WG	180
WNMG-CERMET	173
WNMG-F3M	175
WNMG-F3P	172
WNMG-F3S	176
WNMG-GN	179
WNMG-M3M	175

	WNMG-M3P	173
	WNMG-NF	176
	WNMG-NR	179
	WNMG-PP	178
	WNMG-SF	176
	WNMG-TF	178
	WNMG-TNM	180
	WNMG-VL	177
	WNMG-WF	177
	WNMG-WG	177
	WNMM-NM	179
	WNMX-M3/4MW	181
	WNMX-M3/4PW	181
	WOMG-10-T3P-IQ	174
	WOMG-13-R3P-IQ	174
	WPEX	265
X	XNMG-F3M	195
	XNMG-F3P	194
	XNMG-M3M	195
	XNMG-M3P	194
	XNUW	402
	XNUWB	498
	XNUWB (light fit / tight fit)	499
	XOMT-DT	255
Y	YNMG-F3P	208
	Y-PCHRS-17	340, 432
	Y-PCHRS-17-JHP	341, 433
	Y-SCHR-22BF	407
	Y-SCHR-22BF-JHP	408
	Y-SDJCR-S	76
	Y-SDJCR-S-JHP	77
	Y-SVJCR-S	85
	Y-SVJCR-S-JHP	86

ISCAR LTD.**Israel****Headquarters**

Tel +972 (0)4 997 0311
 Fax+972 (0)4 987 3741
 headquarter@iscar.co.il

Argentina

ISCAR TOOLS ARGENTINA SA
 Tel +54 114 912 2200
 Fax+54 114 912 4411
 admin@iscararg.com.ar

Australia

ISCAR AUSTRALIA PTY. LTD
 Tel +61 (0) 2 8848 3500
 Fax+61 (0) 2 8848 3511
 iscaraus@iscar.com.au

Austria

ISCAR AUSTRIA GmbH
 Tel +43 7252 71200-0
 Fax+43 7252 71200-999
 office@iscar.at

Belarus

JV ALC "TWING-M"
 Tel/Fax: +375 17 511 82 91
 Tel/Fax: +375 17 511 82 93
 Tel/Fax: +375 17 511 82 95
 info@twing.by
 www.twing.by

Belgium

n.v. ISCAR Benelux s.a.
 Tel +32 (0) 2 464 2020
 Fax+32 (0) 2 522 5121
 info@iscar.be

Bosnia

(Representative Office)
 Tel +387 32 201 100
 Fax+387 32 201 101
 info@iscar.ba

Brazil

Iscar do Brasil Coml. Ltda.
 Tel +55 19 3826-7100
 Fax+55 19 3826-7171
 DDG 0800 701 8877
 iscar@iscarbrasil.com.br

Bulgaria

ISCAR BULGARIA
 Tel/Fax +359 431 62557
 aa_iscar@infotel.bg

Canada

ISCAR TOOLS INC.
 Tel +1 905 829 9000
 Fax+1 905 829 9100
 admin@iscar.ca

Chile

J&A INTERNATIONAL
 Tel +56 2 2232 5838
 amedina@jya.cl
 www.jya.cl

China

ISCAR CHINA
 Tel +86 21 8024 8888
 iscar@iscar.com.cn

Colombia

ISCAR Andina
 Tel +57 310 380 9932
 Tel/fax +57 1 896 65 78
 iscar@iscar.com.co

Croatia

ISCAR ALATI d.o.o.
 Tel +385 (0) 1 33 23 301
 Fax+385 (0) 1 33 76 145
 podrska@iscar.hr

Cyprus

WAMET (Demetriades) Ltd.
 Tel +357 (0) 2 336660/5498
 Fax+357 (0) 2 333386
 wamet@cytanet.com.cy

Czech Republic

ISCAR CR s.r.o.
 Tel +420 377 420 625
 Fax+420 377 420 630
 iscar@iscar.cz

Denmark

KJ VAERKTOEJ AS/ISCAR DENMARK
 Tel +45 70 11 22 44
 Fax+45 46 98 67 10
 kj@kj.dk

Ecuador

ISCAR Andina
 Tel/fax +57 1 821 93 38
 iscar@iscar.com.co
 atencioncliente@iscar.com.co

Estonia

KATOMSK AS
 Tel +372 6775 671
 Fax+372 6720 266
 aleksei@katomsk.ee

Finland

ISCAR FINLAND OY
 Tel +358-(0)9-439 1420
 Fax+358-(0)9-466 328
 info@iscar.fi

France

ISCAR FRANCE SAS
 Tel +33 (0)1 30 12 92 92
 info@iscar.fr

Germany

ISCAR Germany GmbH
 Tel +49 (0) 72 43 9908-0
 gmbh@iscar.de
 www.iscar.de

Greece

INTERNATIONAL TOOLS
 K.-X. GEORGOPOULOS & SIA O.E
 Tel +30 210 346 0133
 Fax+30 210 342 5621
 info@internationaltools.gr

VIMA

V. Mazloumian & Sons
 Tel +30 2310 517-117 / 544-521
 Fax+30 2310 529-107
 vimaco@otenet.gr
 http://www.vimaco.gr

Hong Kong

MTC TOOLING SYSTEMS LTD
 Tel +85-2-23054838
 Fax+85-2-27988789
 yoongkamsing@hotmail.com

Hungary

ISCAR HUNGARY KFT.
 Tel +36 28 887 700
 Fax+36 28 887 710
 iscar@iscar.hu

India

ISCAR India Ltd.
 Tel +91 77009 63707
 sales@iscar.in

Indonesia

CV MULTI TEKNIK
 Tel +62-21-29206242/44/45/59
 Fax+62-21-29206243
 contact@multi-teknik.co.id

Ireland

HARD METAL MACHINE TOOLS
 Tel +353 (0) 1 286 2466
 Fax+353 (0) 1 286 1514
 phannigan@hardmetal.ie
 www.hardmetal.ie

Italy

ISCAR ITALIA srl
 Tel +39 02 93 528 1
 Fax+39 02 93 528 213
 marketing@iscaritalia.it

Japan

ISCAR JAPAN LTD.
 Tel +81 6 6835 5471
 Fax+81 6 6835 5472
 iscar@iscar.co.jp

Kazakhstan

ISCAR Kazakhstan Ltd.
 Tel: +7 717 299 9835,
 Tel: +7 700 021 9835
 Tel: +7 707 850 1027
 info@iscar.kz

Latvia

MECHA, UAB
 Tel +370 37 407 230
 Fax+370 37 407 231
 info@mecha.lt

Lithuania

MECHA, UAB
 Tel +370 37 407 230
 Fax+370 37 407 231
 sigitas@mecha.lt

Mexico

ISCAR DE MÉXICO
 Tel +52 (442) 214 5505
 Fax+52 (442) 214 5510
 iscarmex@iscar.com.mx

Morocco

2 rue des
 Fauvettes Oasis
 20103 Casablanca
 Tel +212 (0) 7 62 23 48 56
 hachem@iscar.ma

The Netherlands

ISCAR NEDERLAND B.V.
 Tel +31 (0) 182 535523
 Fax+31 (0) 182 572777
 info@iscar.nl

New Zealand

ISCAR PACIFIC LTD.
 Tel +64 (0) 9 573 1280
 Fax+64 (0) 9 573 0781
 iscar@iscarpac.co.nz

North Macedonia

(Representative Office)
 Tel +389 2 309 02 52
 Fax+389 2 309 02 54
 info@iscar.com.mk

Norway

SVEA MASKINER AS
 Tel +47 32277750
 Fax+47 32277751
 per.martin.bakken@svea.no

Peru

HARTMETALL SAC
 Tel: (511) 6612699
 otorres@hartmetallgroup.com

Philippines

MESCO
 Tel +63 2631 1775
 Fax+63 2635 0276
 mesco@mesco.com.ph

Poland

ISCAR POLAND Sp. z o.o.
 Tel +48 32 735 7700
 Fax+48 32 735 7701
 iscar@iscar.pl

Portugal

ISCAR Portugal, SA
 Tel +351 256 579950
 Fax+351 256 586764
 info@iscarportugal.pt

Romania

ISCAR Tools SRL
 Tel +40 (0)312 286 614
 Fax+40 (0)312 286 615
 iscar-romania@iscar.com

Serbia

ISCAR TOOLS d.o.o.
 Tel +381 11 314 90 38
 Fax+381 11 314 91 47
 info@iscartools.rs

Singapore

SINO TOOLING SYSTEM
 Tel +65 6566 7668
 Fax+65 6567 7336
 sinotool@singnet.com.sg

Slovakia

ISCAR SR, s.r.o.
 Tel +421 (0) 41 5074301
 Fax+421 (0) 41 5074311
 info@iscar.sk

Slovenia

ISCAR SLOVENIJA d.o.o.
 Tel +386 1 580 92 30
 Fax+386 1 562 21 84
 info@iscar.si

South Africa

ISCAR SOUTH AFRICA (PTY) LTD.
 ShareCall 08600-47227
 Tel +27 11 997 2700
 Fax+27 11 388 9750
 iscar@iscarsa.co.za

South Korea

ISCAR KOREA
 Tel +82 53 760 7594
 Fax+82 53 760 7500
 leeyj@taegutec.co.kr

Spain

ISCAR IBERICA SA
 Tel +34 93 594 6484
 Fax+34 93 582 4458
 iscar@iscarib.es

Sweden

ISCAR SVERIGE AB
 Tel +46 (0) 18 66 90 60
 Fax+46 (0) 18 122 920
 info@iscar.se

Switzerland

ISCAR HARTMETALL AG
 Tel +41 (0) 52 728 0850
 Fax+41 (0) 52 728 0855
 office@iscar.ch

Taiwan

ISCAR Taiwan Ltd.
 Tel +886 (0)4-24731573
 Fax+886 (0)4-24731530
 iscar.taiwan@msa.hinet.net

Thailand

ISCAR Thailand Ltd.
 Tel +66 (2) 7136633-8
 Fax+66 (2) 7136632
 iscar@iscarthailand.com

Turkey

ISCAR Kesici Takim
 TIC. VE. IML. LTD
 Tel +90 (262) 751 04 84 (Pbx)
 Fax+90 (262) 751 04 85
 iscar@iscar.com.tr

Ukraine

ISCAR UKRAINE LLC
 Tel +38 (050) 440 23 91
 info@iscar.com.ua

United Arab Emirates

ISCAR GULF TRADING LLC
 Tel +971 4 886 4547
 www.svrs-mena.com

United Kingdom

ISCAR TOOLS LTD.
 Tel +44 (0) 121 422 8585
 Fax+44 (0) 121 423 2789
 sales@iscar.co.uk

United States

ISCAR USA
 Arlington
 USA Headquarters
 300 Westway Place
 Arlington, TX 76018
 Tel +1 817-258-3200
 usmarketing@iscarusa.com

Charlotte

Productivity Center
 3020 Whitehall Park Drive
 Charlotte, NC 28273
 Tel +1 817 258-3202
 usmarketing@iscarusa.com

Venezuela

FERREINDUSTRIAL ISO-DIN C.A.
 Tel +58 2 632 8211/633 4657
 Fax+58 2 632 5277
 iso-din@cantv.net

Vietnam

ISCAR VIETNAM
 (Representative Office)
 Tel +84 8 38 123 519/20
 Fax+84 8 38 123 521
 iscarvn@hcm.fpt.vn

04/2025



3477708 G

www.iscar.com

Please check ISCAR's online catalog for the most current technical information regarding our products

© 2013 Iscar Ltd. This document, as well as all information and other data contained herein and/or derived therefrom, including but not limited to, all trademarks, logos, trade-names, concepts, pictures, designs and/or devices, as well as any data from which any proprietary and/or intellectual property right may emanate ("Information"), is the sole and exclusive property of Iscar Ltd. and is protected by copyright and other applicable laws. No part of any Information may be used or otherwise disseminated for any purpose whatsoever without the express prior written consent of Iscar Ltd. Items appearing in this catalog may be improved, amended or withdrawn without prior notice."

YOU

INTELLIGENTLY?

MACHINING

ISCAR TURNING LINES

Metric Catalog



Download **ISCAR WORLD APP**



E-CAT



NEO ITA

